

It's About Time !!!!!

Timing for VLBI



Tom Clark

NVI/NASA GSFC

[mailto: K310@verizon.net](mailto:K310@verizon.net)

- and -



Rick Hambly

CNS Systems, Inc.

[mailto: Rick@cnsys.com](mailto:Rick@cnsys.com)



Technical Operations Workshop
MIT Haystack Observatory
6-9 May 2013

The difference between Frequency and Time Oscillators and Clocks

Oscillator

- Escapement Wheels & Pendulums
- Crystal Oscillators
- Cavity Oscillators
- Oscillator Locked to Atomic Transition
 - Rubidium (6.8 GHz)
 - Cesium (9.1 GHz)
 - Hydrogen Maser (1.4 GHz)

Integrator and Display = Clock

- Gears
- Electronic Counters
- Real Clocks

Events that occur
with a defined

FREQUENCY

nsec -- minutes

Long-Term

TIMING

seconds - years

What “Clock” Performance Does VLBI Need?

- The VLBI community (Radio Astronomy and Geodesy) uses Hydrogen Masers at 40-50 remote sites all around the world.
- To achieve $\sim 10^\circ$ signal coherence for ~ 1000 seconds at 10 GHz we need the 2 clocks (oscillators) at the ends of the interferometer to maintain relative stability of:
 - $\approx [10^\circ / (360^\circ * 10^{10} \text{Hz} * 10^3 \text{sec})]$
 - $\approx 2.8 * 10^{-15}$ @ 1000 sec.

1

What “Clock” Performance Does VLBI Need?

- In Geodetic applications, the station clocks are modeled at relative levels ~ 30 psec over a day:

- $\approx [30 \times 10^{-12} / 86400 \text{ sec}]$
- $\approx 3.5 \times 10^{-16} @ 1 \text{ day}$

2

What “Clock” Performance Does VLBI Need?

3

- To correlate data acquired at 16Mb/s, station timing at relative levels ~ 50 nsec or better is needed. After a few days of inactivity, this requires:
 - $\approx [50 * 10^{-9} / 10^6 \text{ sec}]$
 - $\approx 5 * 10^{-14} @ 10^6 \text{ sec}$
- Since VLBI now defines UT1, VLBI needs to control $[\text{UTC}_{(\text{USNO})} - \text{UTC}_{(\text{VLBI})}]$ with an **ACCURACY** (traceable to USNO)
 - $\approx 100 \text{ nsec} - 1 \mu\text{sec}$
- To detect problems, VLBI should monitor the long-term behavior of the Hydrogen Masers (at least) every hour with **PRECISION**
 - $\approx 10\text{-}50 \text{ nsec}$

Allan Deviation – A graphical look at clock performance

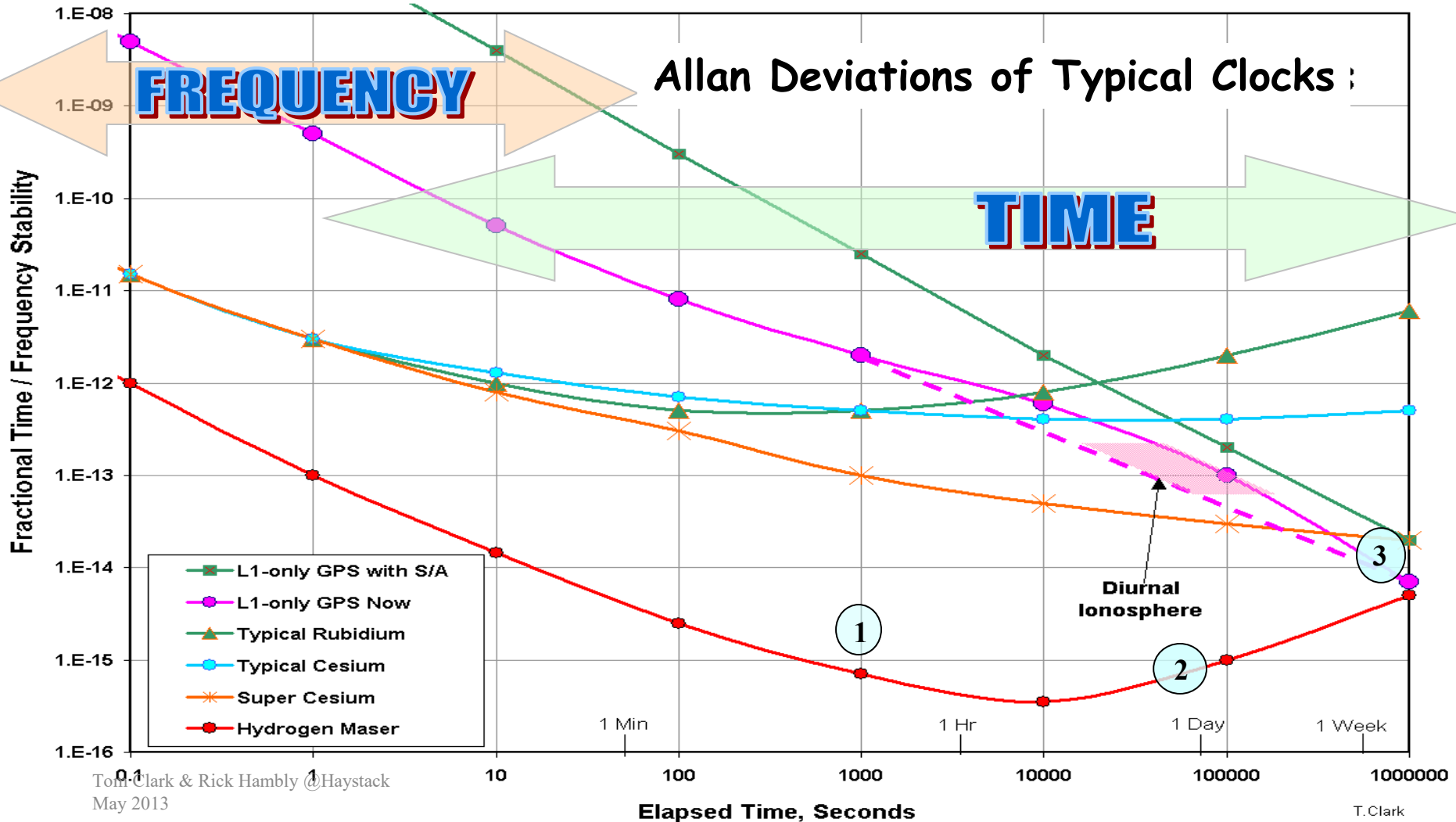

Why do we need to worry about “Absolute Time” (i.e. Clock Accuracy) in VLBI?

- The ONLY real reason for worrying about “absolute time” is to relate the position of the earth to the position of the stars:
 - Generating Sidereal Time to point antennas.
 - Measuring UT1 (i.e. “Sundial Time”) to see changes due to redistribution of mass in/on the earth over long periods of time (a.k.a. “The Reference Frame”)
 - Knowing the position of the earth with respect to the moon, planets and satellites.
 - Making the correlation and Data Analysis jobs easier

Why do we need to worry about “Absolute Time” (i.e. Clock Accuracy) in VLBI?

At the stations this means that we will need to pay more attention to timing elements like

- Frequency Standard and Station Timing
- The lengths of all signal & clock cables
- The geometry of the feed/receiver to the antenna.
- Calibration of instrumental delays inside the receiver and backend. The development of new instrumentation is needed.
- The care with which system changes are reported to the correlators and the data analysts.

VLBI Data Analysis assumes the Geometric Clock is at the Intersection of Axes of the Antenna *

VLBI's "REAL" Clocks (#1)

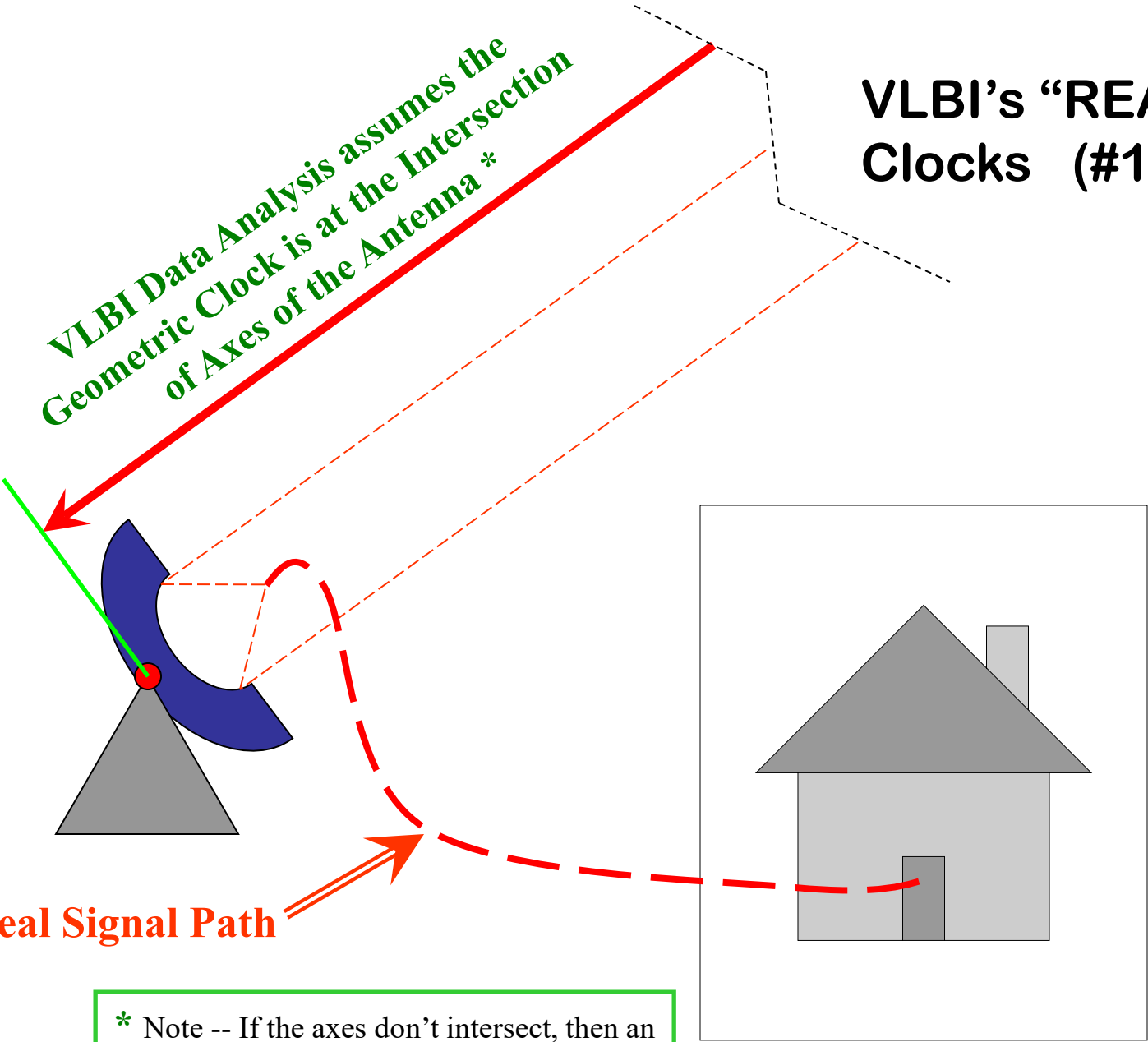

The Real Signal Path

* Note -- If the axes don't intersect, then an "offset axis" model of the antenna is used

VLBI's "REAL" Clocks (#2)

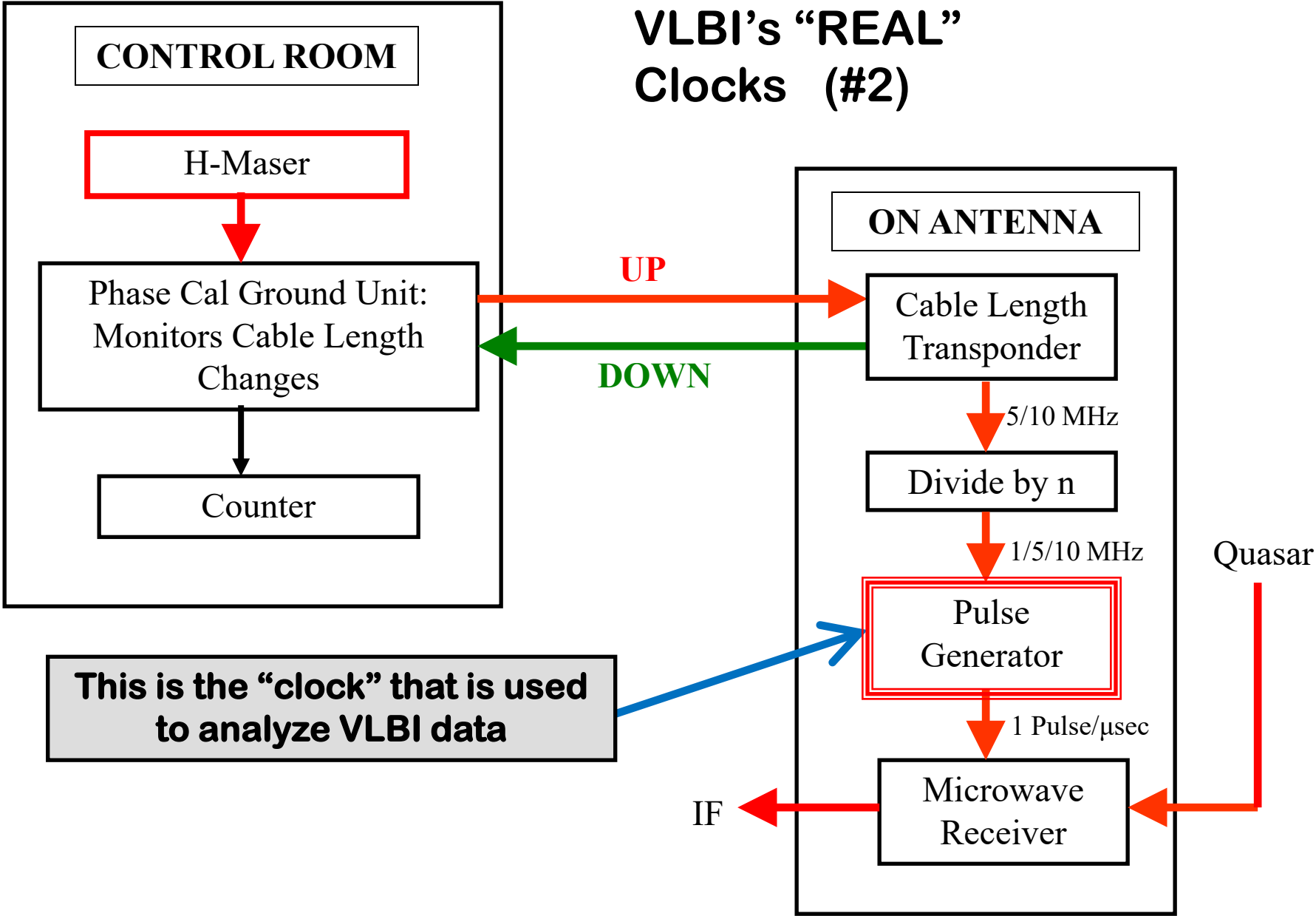

VLBI's "REAL" Clocks (3)

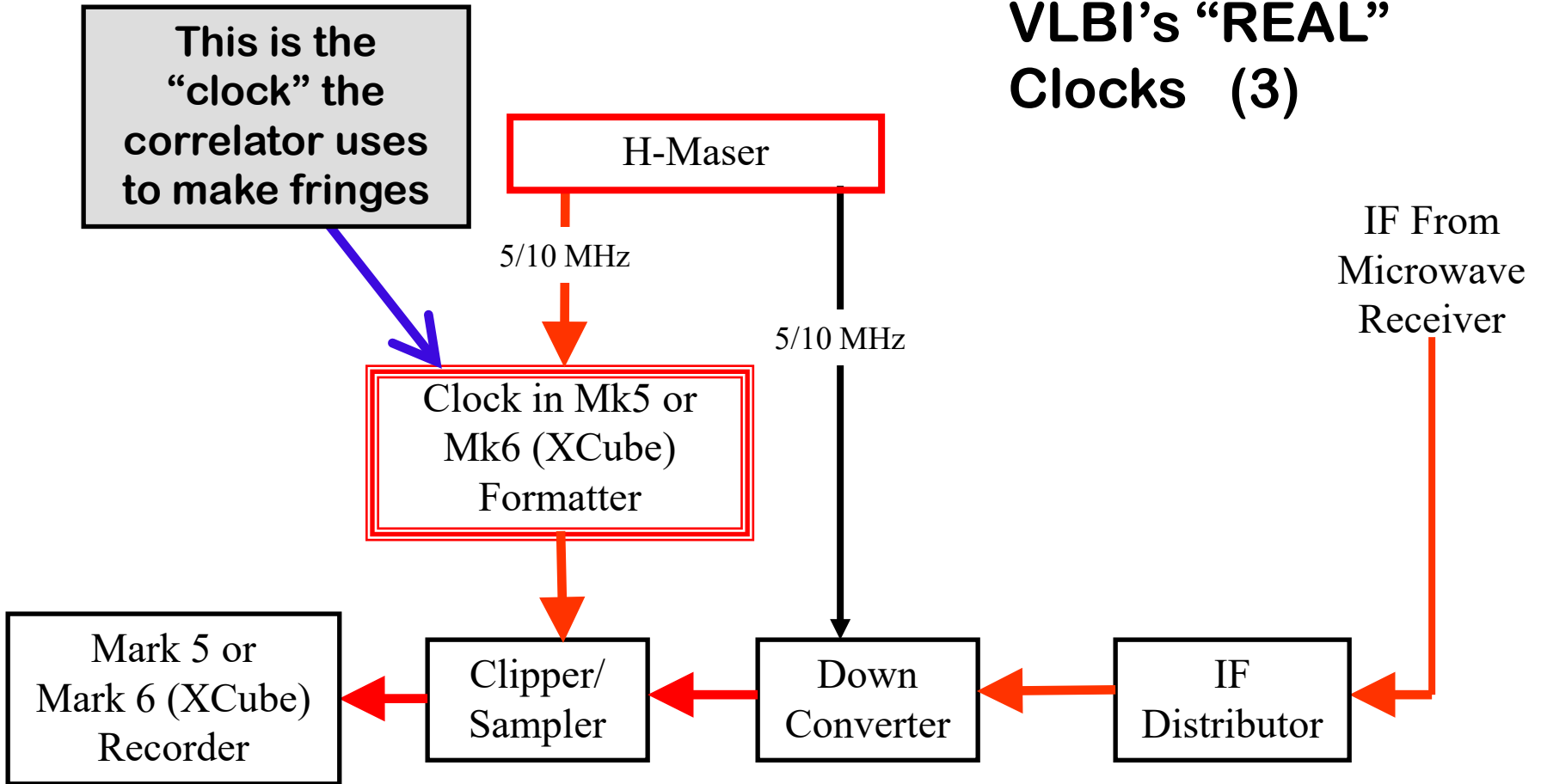

Setting VLBI Clock Time & Rate with GPS

-- 3 possible ways--

- ⊗ **Compare two distant clocks by observing the same GPS satellite(s) at the same time (also called Common View)**
 - Requires some intervisibility between sites
 - Requires some near-Real-Time communication
 - Links you directly to the “Master Clock” on the other end at ~1 nsec level
- ⊗ **Use Geodetic GPS receivers (i.e. as an extension of the IGS network)**
 - Requires high quality (probably dual frequency) receiver (TurboRogue, Z12, etc), but it’s hard to gain access to the internal clock.
 - Requires transferring ~1 Mbyte/day of data from site
 - Requires fairly extensive computations using dual-frequency data to get ~300 psec results with ionosphere corrections
 - Allows Geodetic community to use VLBI Site (and H-Maser) for geodesy
 - Difficult to obtain “Real Time” clock pulses!

Blindly use the Broadcast GPS Timing Signals as a clock

- Yields “Real Time” ~10-30 nsec results with ~ \$1000 hardware
- Single Frequency L1 only (for now) causes ionospheric error

Timing at an Isolated, Remote VLBI Site -- Urumqi in Xinjiang Province, China



Old and New Timing Systems at Wettzell (2009)

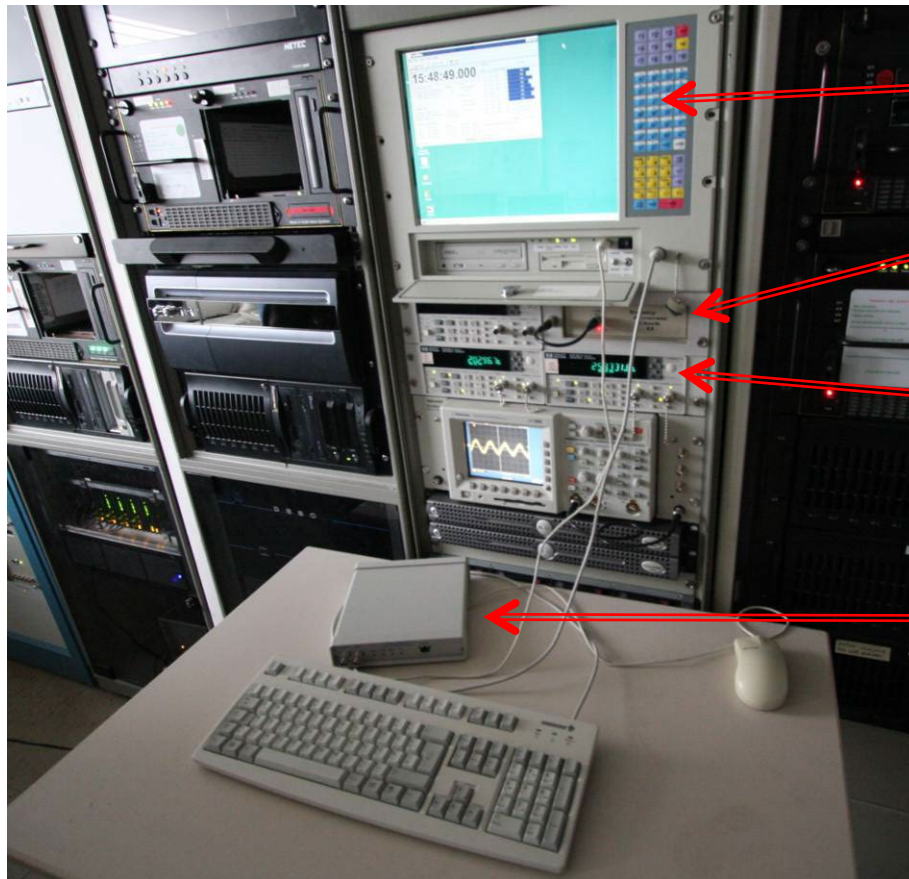

Rick's Tac32Plus
Software

Tom's old 8
channel "TAC"

HP53132A
Counters

Rick's New
12- channel
"CNS Clock II"

An Early Example of "Blind" GPS Timing with a 6 channel receiver

ONSALA H-Maser vs "TAC" GPS

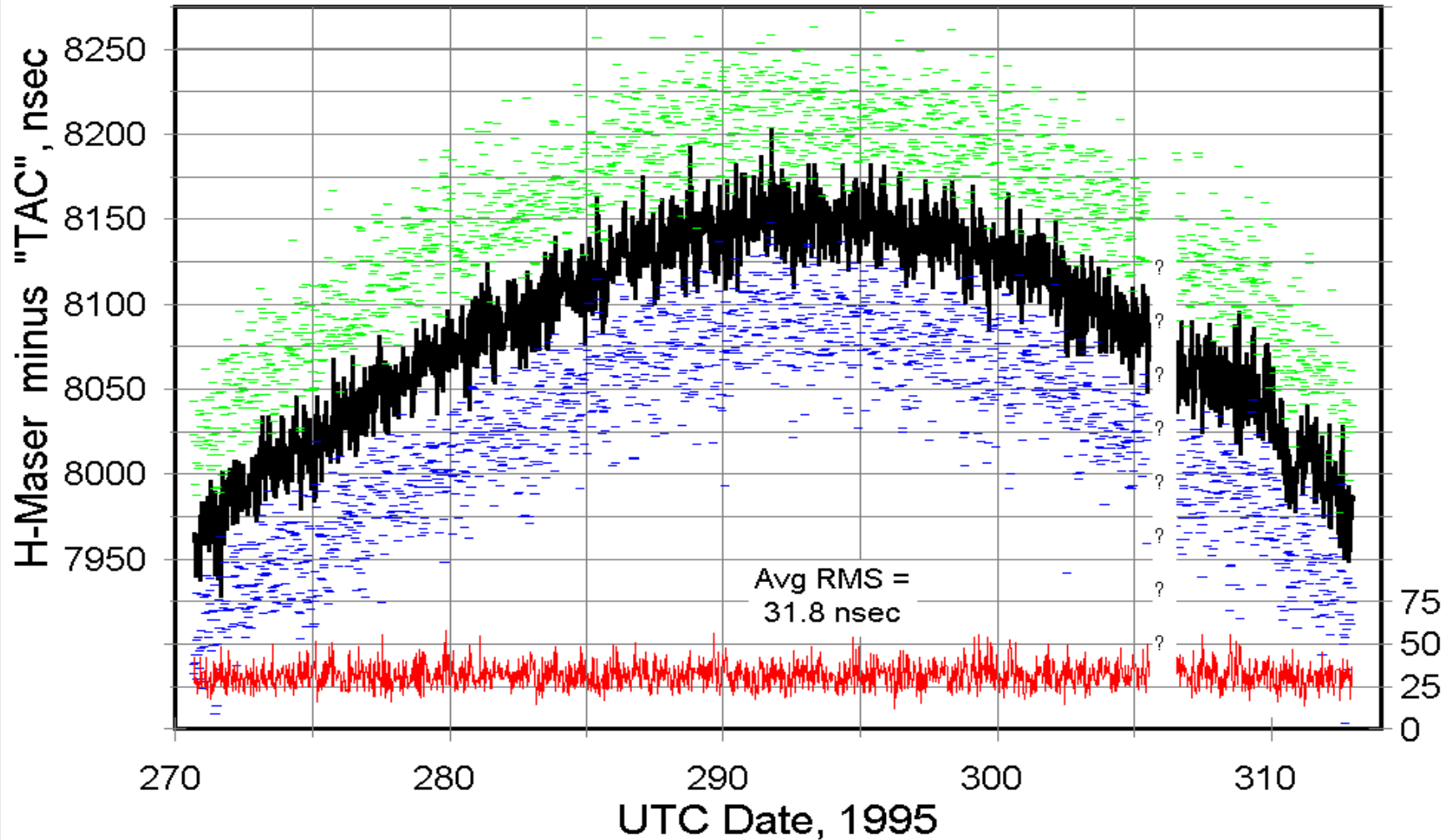

Before S/A was turned off (8-channel) . . .

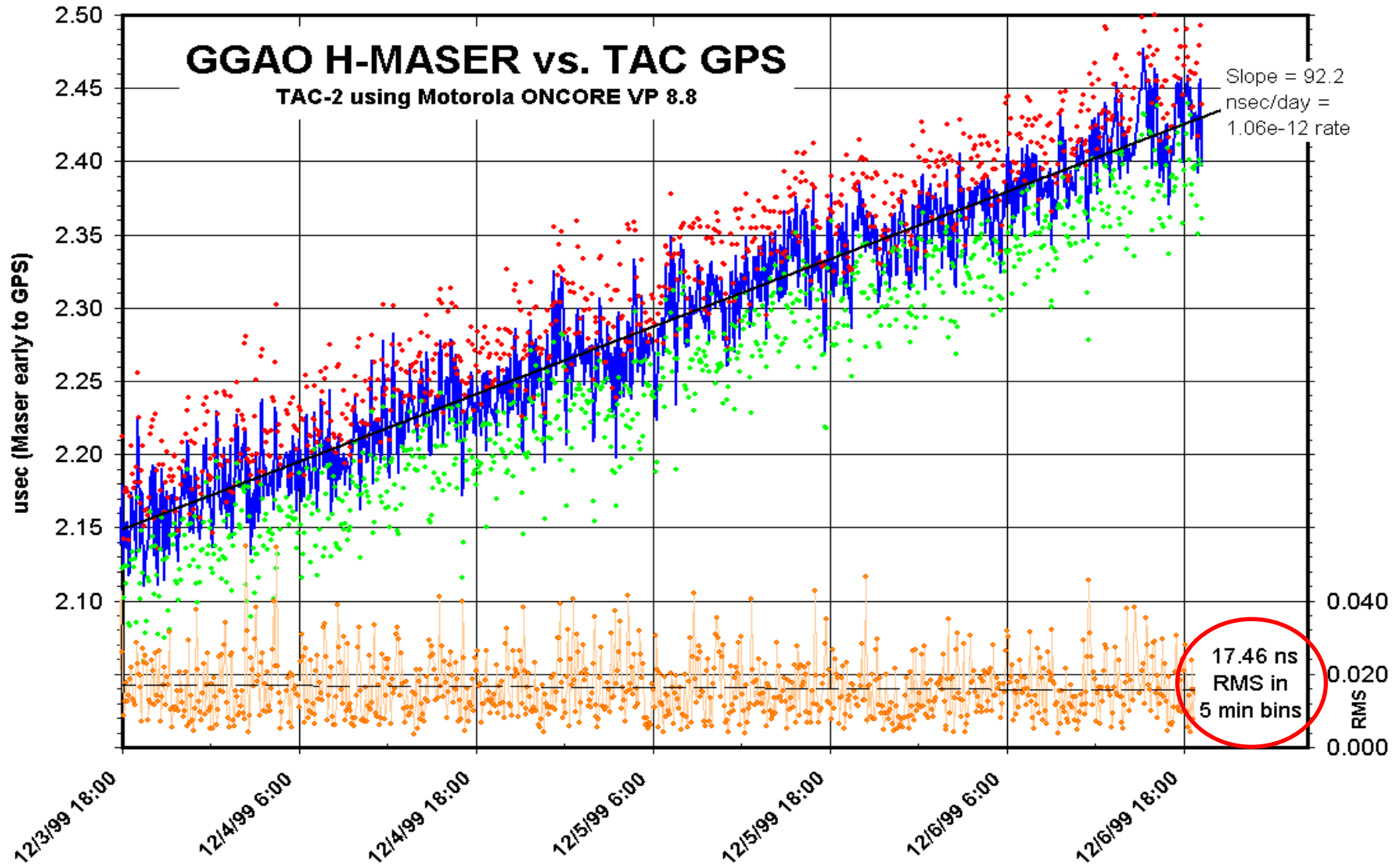

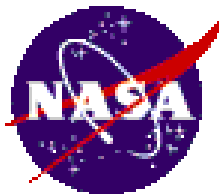

GGAO (Goddard Geophysical & Astronomical Observatory)

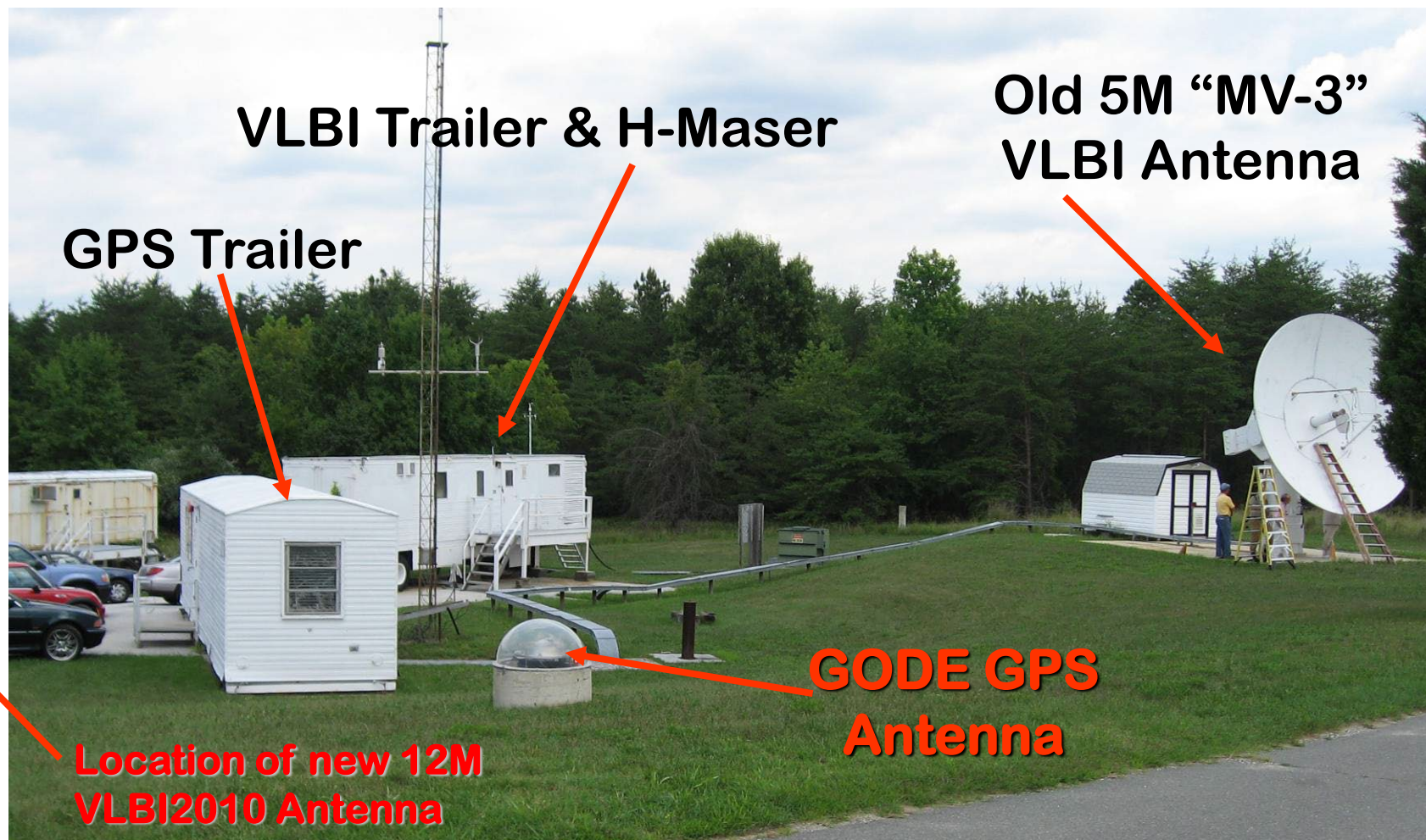

How we got ~30 nsec timing in 1995 *even with S/A*

- Start with a good timing receiver, like the Motorola ONCORE
 - Average the positioning data for ~1-2 days to determine the station's coordinates. With S/A on, a 1-2 day average should be good to <5 meters. Or if the site has been accurately surveyed, use the survey values.
 - Lock the receiver's position in "Zero-D" mode to this average.
 - Make sure that your Time-Interval Counter (TIC) is triggering cleanly. Start the counter with the 1 PPS signal from the "house" atomic clock and stop with the GPS receiver's 1PPS.
 - Average the individual one/second TIC reading over ~5 minutes.
-
- **All these steps have been automated in my SHOWTIME and in CNS System's Tac32Plus Software using a barebones PC**

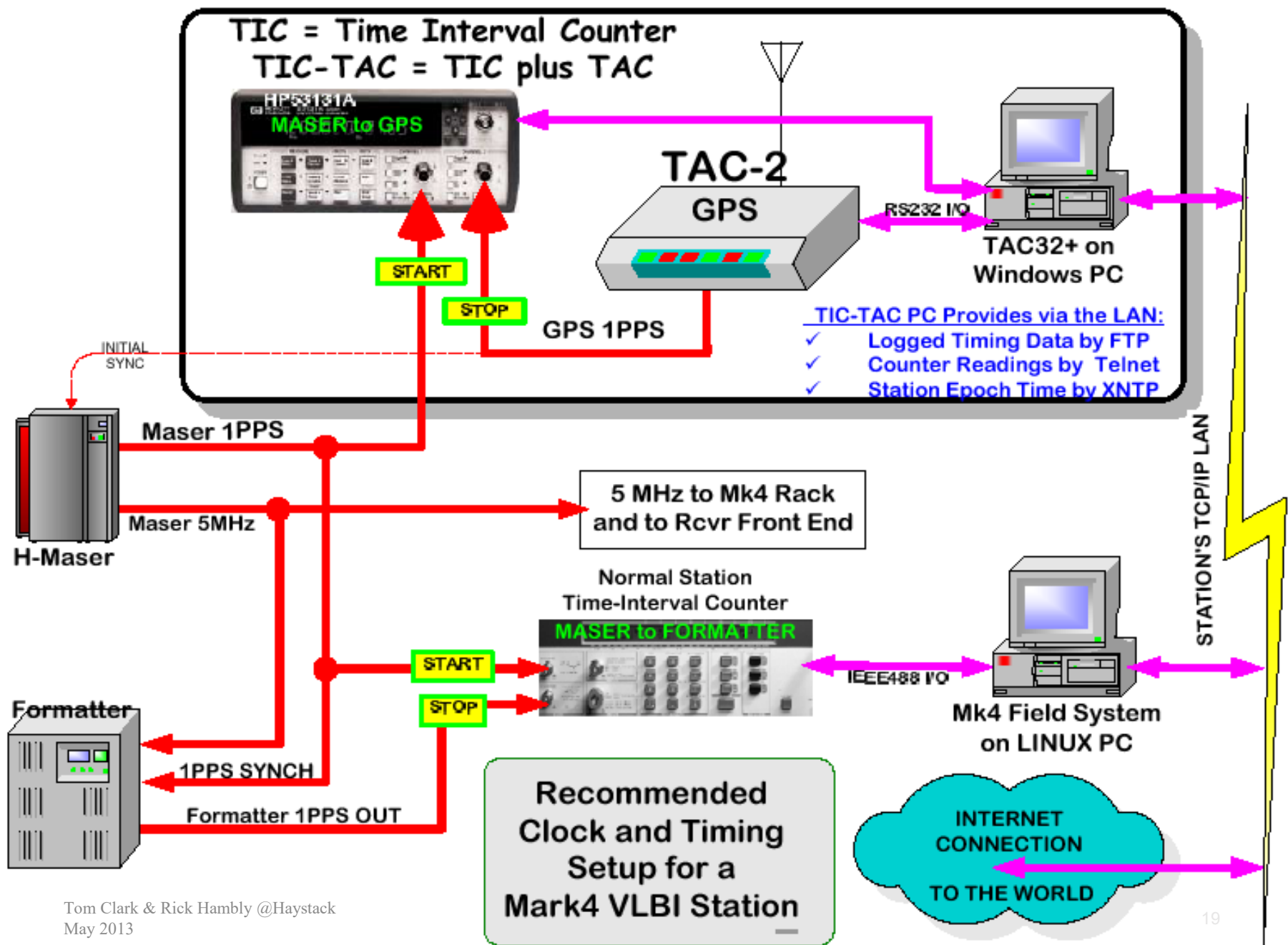

All that is ancient history. In the new millennium, let's now discuss . . .

- **What happened when the DoD turned off S/A on May 2, 2000.**
- **Sawtooth and Glitches – Some Receiver Defects**
- **Some results obtained with Motorola's newer low cost timing receiver, the M12+ and M12M**
- **“Absolute” Receiver Calibration**
- **The post-Motorola era & new developments**

What happened when S/A went away?

Using 8-channel Motorola ONCORE VP Receiver . . .

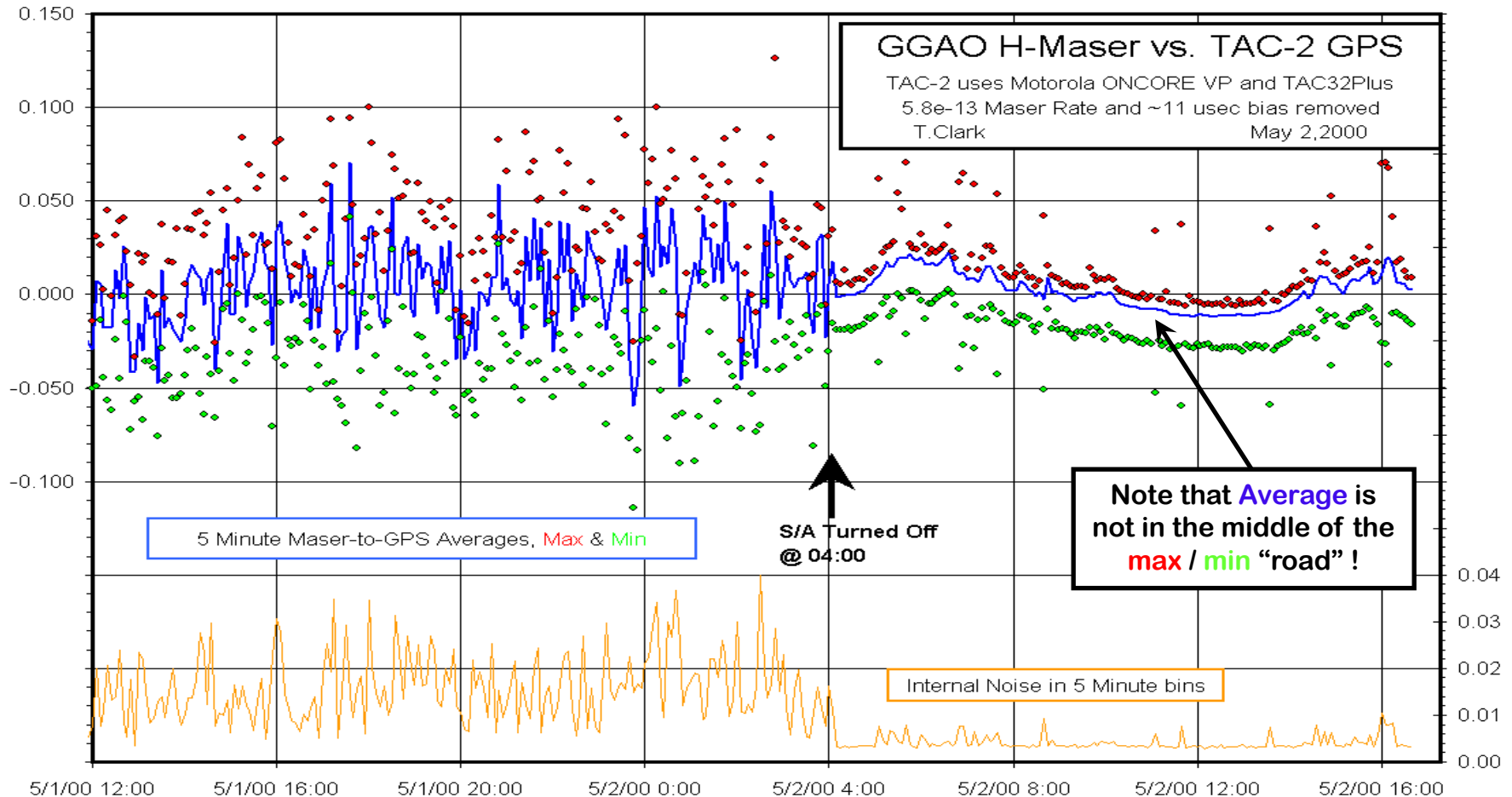

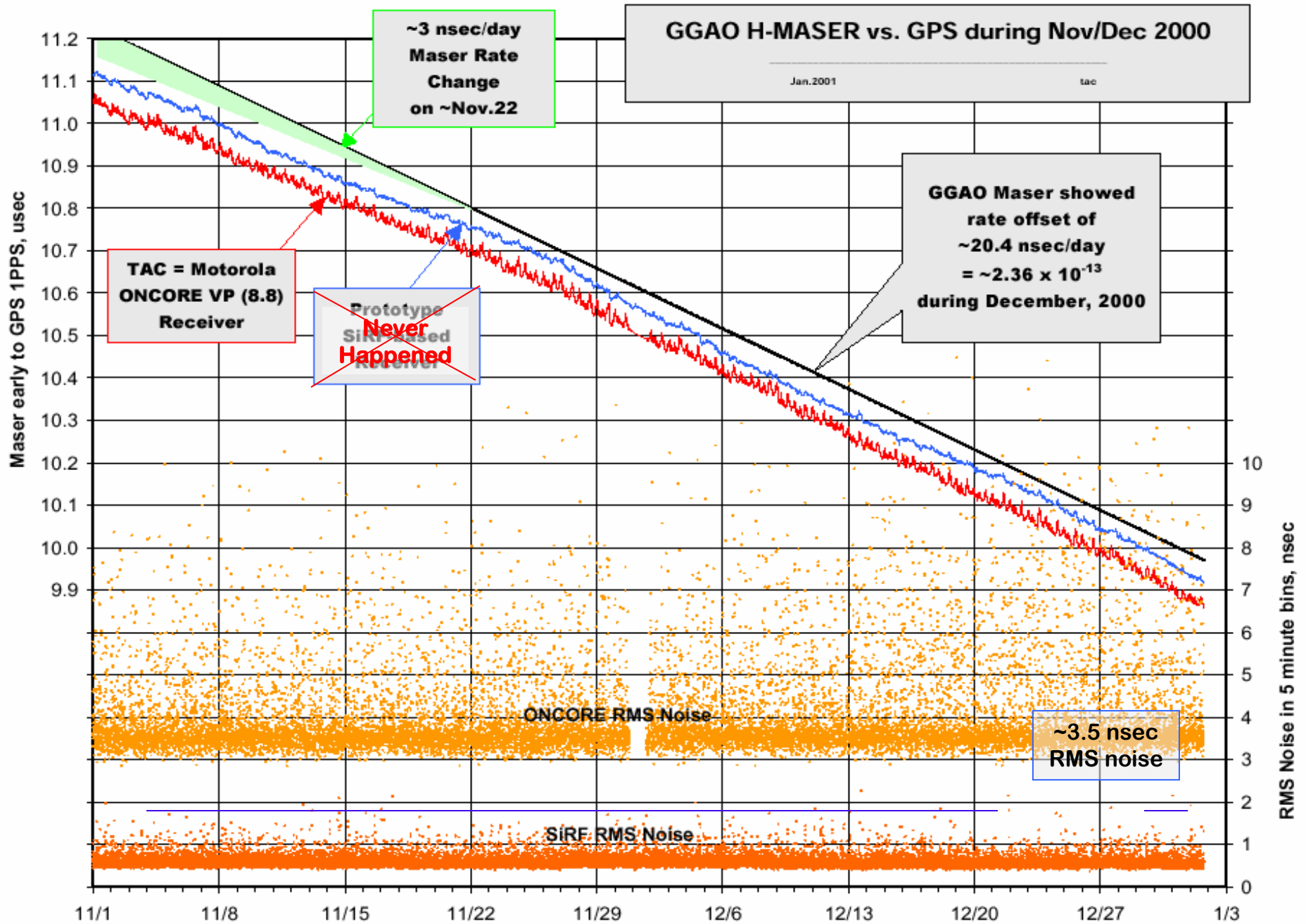

An example of 1PPS Sawtooth & Bad Glitches Motorola's low cost UT+ Oncore (v3.1)

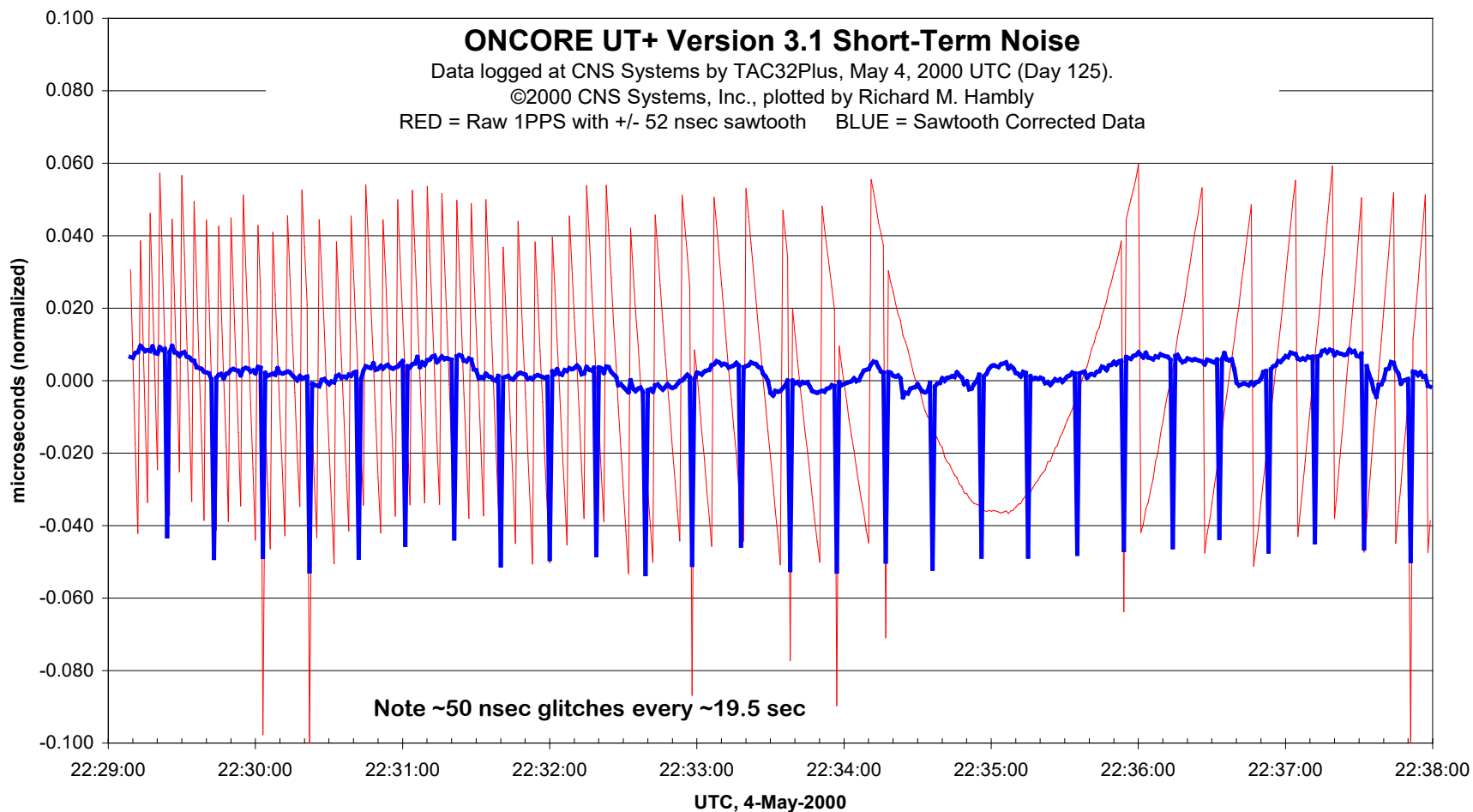

An example of 1PPS sawtooth with Motorola's 12-channel M12+ receiver

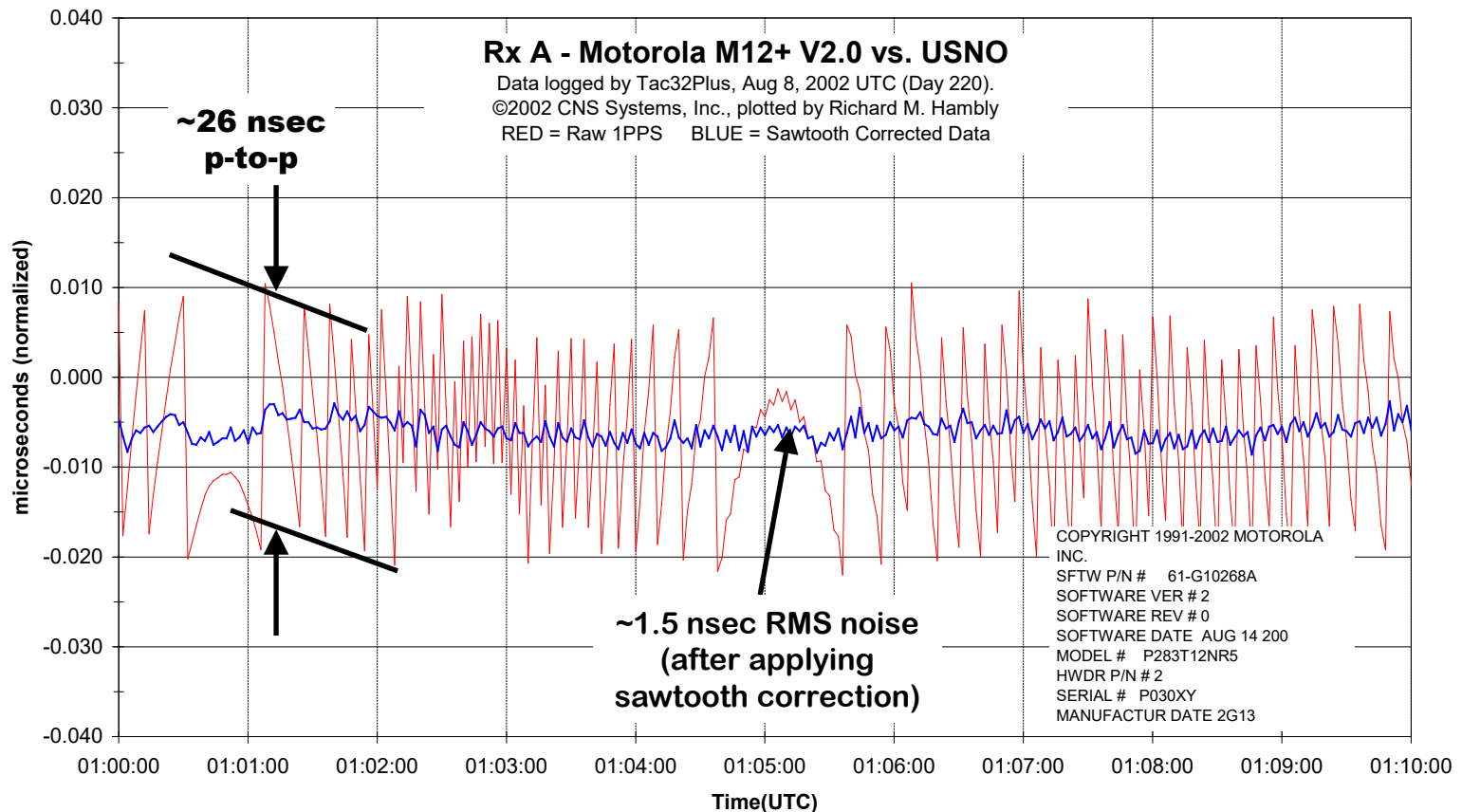

What is the sawtooth effect ????

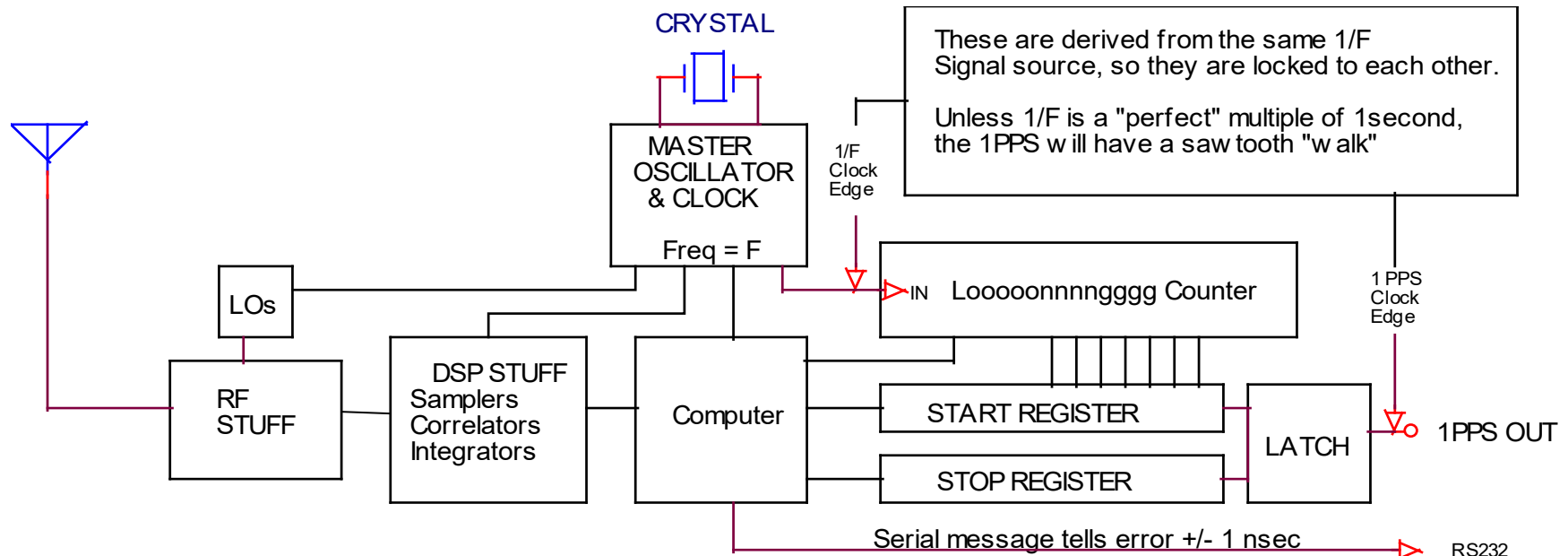

- For the older Oncore, $F=9.54$ MHz, so the $1/F$ sawtooth has a range of +/- 52 nsec (104 nsec peak-to-peak)
- The newer M12+ & M12M have $F \approx 40$ MHz, so the sawtooth has been reduced to +/- 13 nsec (26 nsec).

VLBI's annoying problem caused by the sawtooth timing error

- When the formatter (Mark 5 sampler) needs to be reset, you have to feed it a 1PPS timing pulse to restart the internal VLBI clock. After it is started, it runs smoothly at a rate defined by the Maser's 5/10 MHz.
- The **AVERAGE** of the 1pps pulses from the GPS receiver is "correct", but any single pulse can be in error by ± 13 nsec (or ± 52 nsec with the older VP & UT Oncore receivers) because of the sawtooth.
- Once you have restarted the formatter with the noisy 1 PPS signal, you then measure the actual (GPS minus Formatter) time that you actually achieved.
- Or, you can use the 1PPS from a new CNS Clock II which has the sawtooth "dither" removed.

Errors due to the sawtooth do not compromise VLBI data quality

- All the Motorola receivers report the error on the next 1 PPS pulse with a resolution of ~ 1 nsec as a part of the serial data message.
 - Tac32Plus reads the HP53131/2 counter and the GPS data message and corrects the answer.
-

But, wouldn't it be good if the GPS receiver didn't have any sawtooth error, and that every 1 PPS pulse could be trusted?

How can the Sawtooth noise be eliminated ???

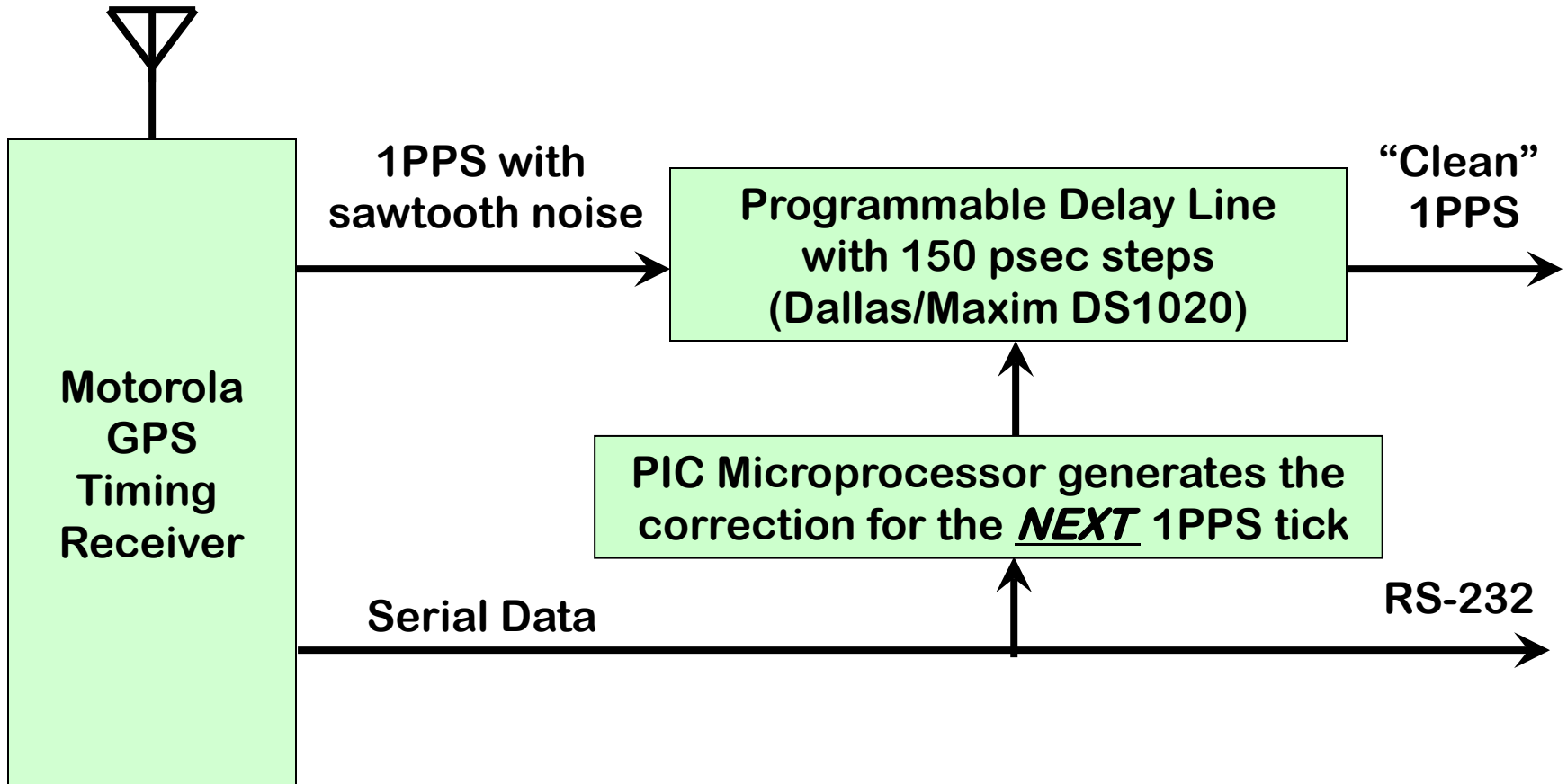

The Future is here now!

The CNS Clock II

1994 – 2004: the TAC



1PPS Sawtooth Correction Option →

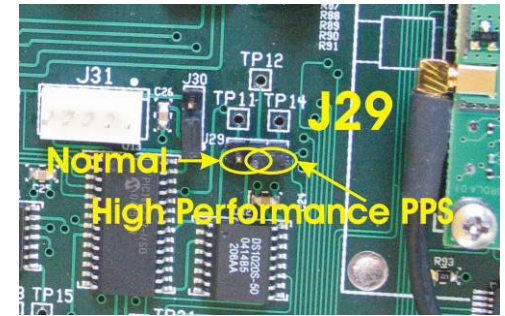

Available Since January 2005



Data available on RS-232, USB 2.0, Ethernet LAN, RS-485 and solid state relay Ports

Ethernet NTP Server for your LAN
TNC GPS Antenna Connector
Buffered 1 PPS outputs
GPSDO 10 (or 5) MHz output
High Performance PPS
Steered TCXO
Steered Oscillator Utility Functions

Many Options: IRIG-B, Sequencer, Genisys, RS-485 RFID Timecode, Steered OCXO, and Event Recorder Interface.

Does the hardware 1PPS correction work?

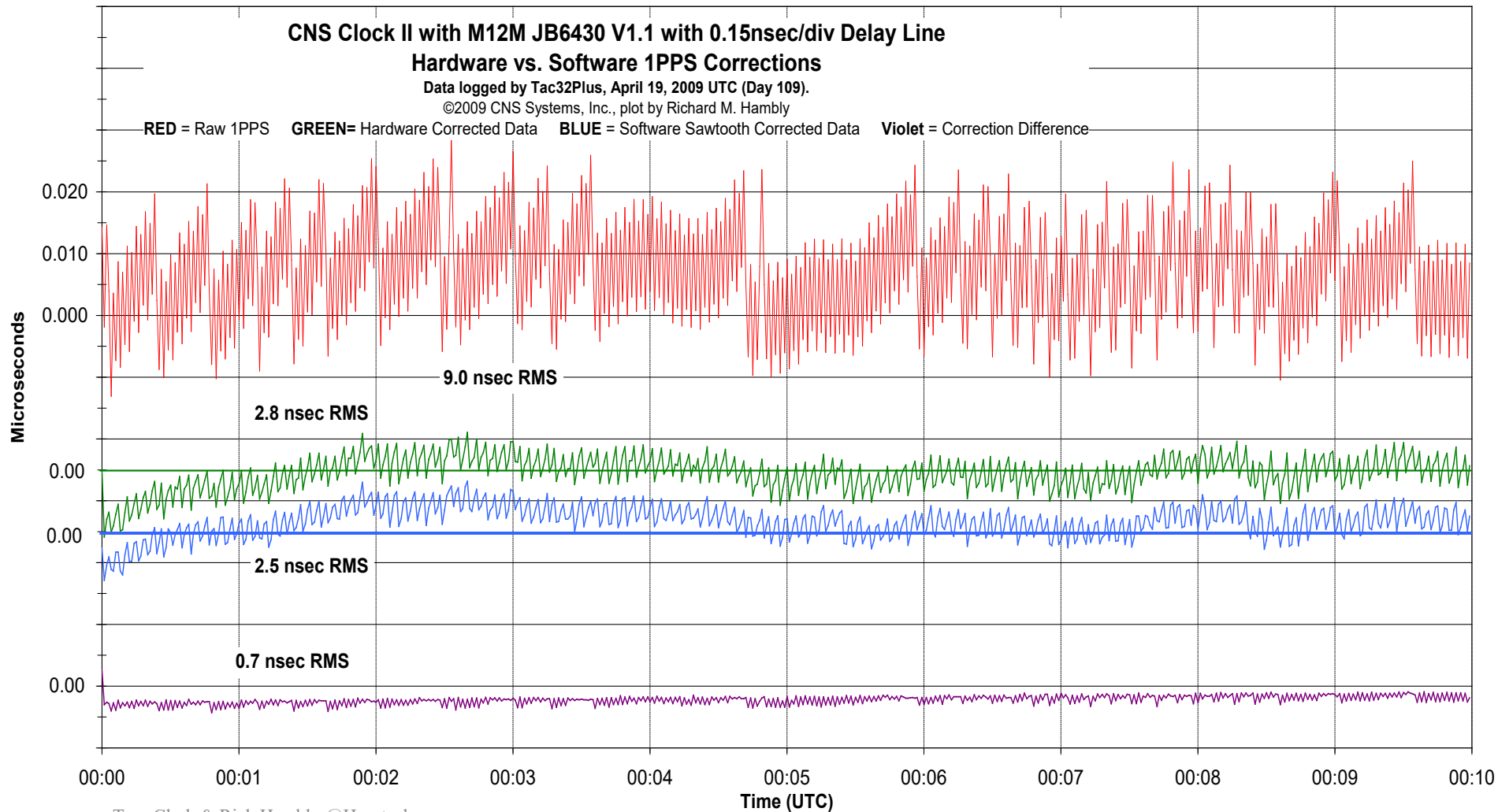

CNS Systems' Test Bed at USNO

Calibrating the “DC” Offset of M12+ receivers with 2.0 Firmware in 2002

We have observed that the ONCORE firmware evolution from 5.x \Rightarrow 6.x \Rightarrow 8.x \Rightarrow 10.x has been accompanied by about 40 nsec of “DC” timing offsets.

Motorola tasked Rick to make the new M12+ receiver be correct.



Tac32Plus software simultaneously processes data from four Time Interval Counters and four CNS Clocks, writing 12 logs continuously.

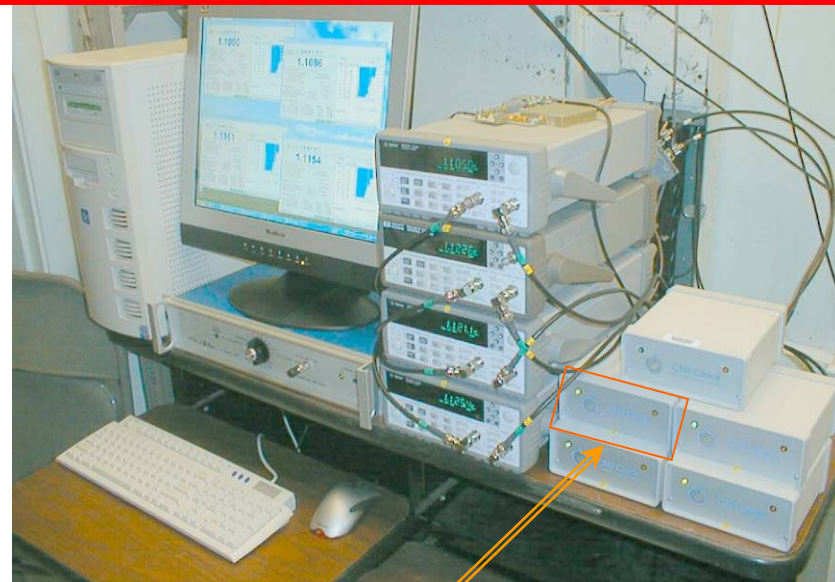

Time Interval Counters compare the 1PPS from each CNS Clock (M12+) against the USNO's UTC time tick.

This is the “Gold Standard” “A” receiver that we used for subsequent calibrations.

Individual M12 Clock Performance

“Gold” Receiver (A) average “DC” offset = -0.6 ns

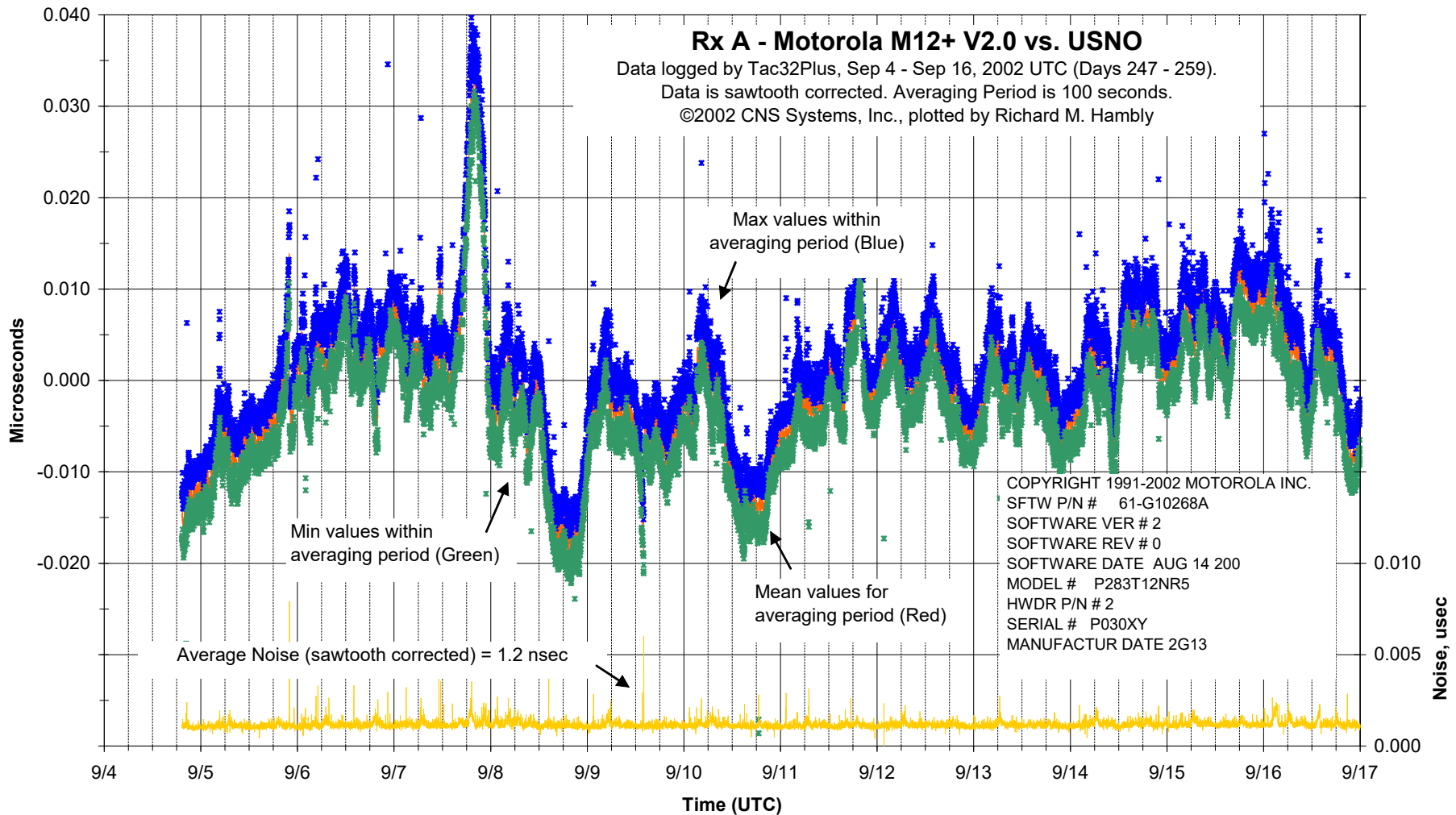

Comparing four M12+ Timing Receivers

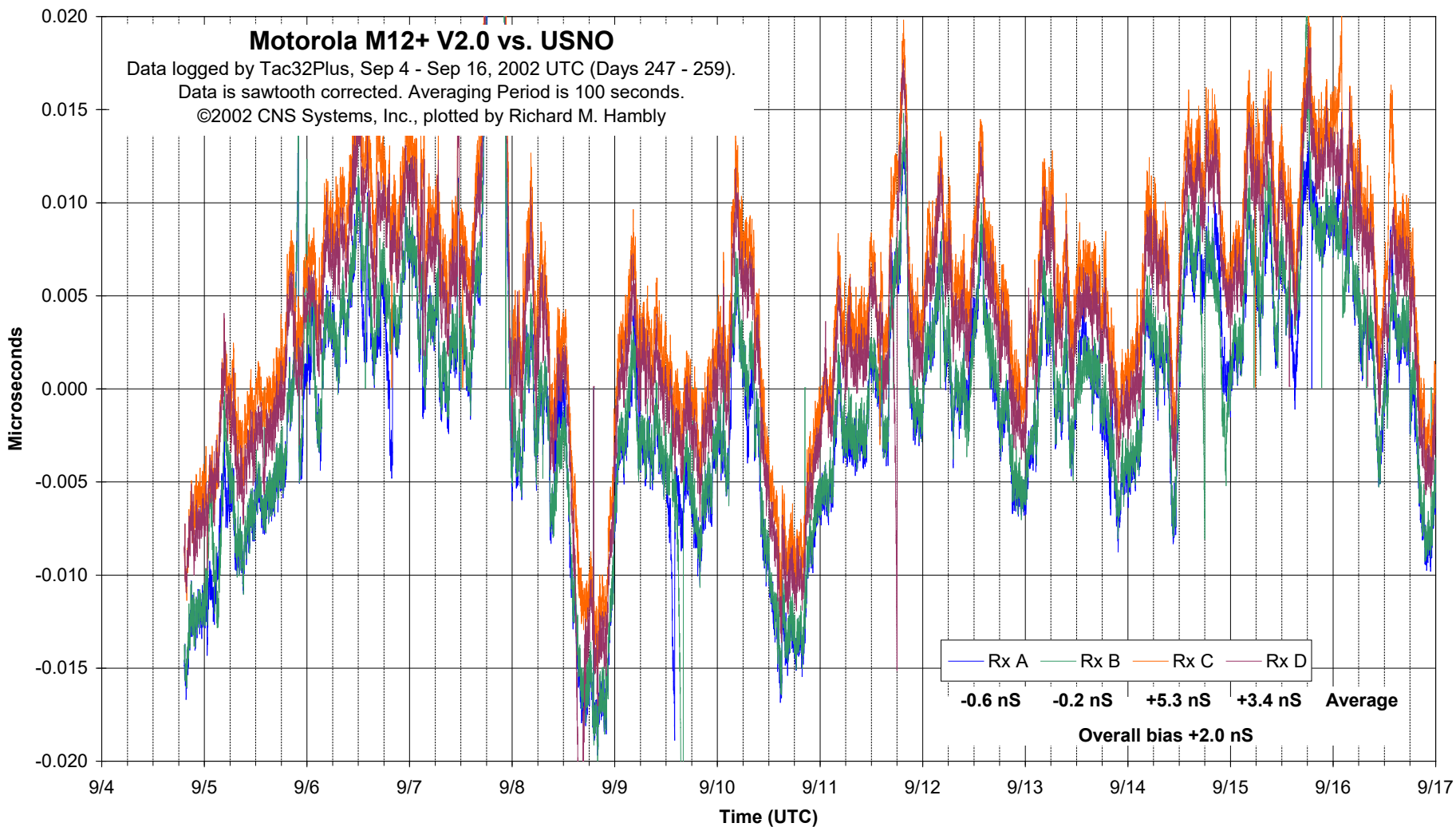

[Trying to keep up with discontinued parts!]

- Around 2005, Motorola made the corporate decision to quit the GPS business and the M-12 design was licensed to iLotus in Singapore. The current iLotus timing receiver is called the M-12M.
- Anticipating the need for a M-12 replacement, Rick & Art Sepin (Synergy) examined the Swiss-built uBlox LEA-6 receiver. Because of the large installed base of Motorola/iLotus receivers, Rick developed a hybrid M-12 emulator; an M-12 sized board and a PIC μ P to convert the uBlox binary command set to the Motorola @@ binary format.

Comparing an M12+, M-12M & uBlox LEA-6

An iLotus M-12M module. The M12+ looks just the same



Top side The Synergy uBlox LEA6T module

All the guts are on Bottom

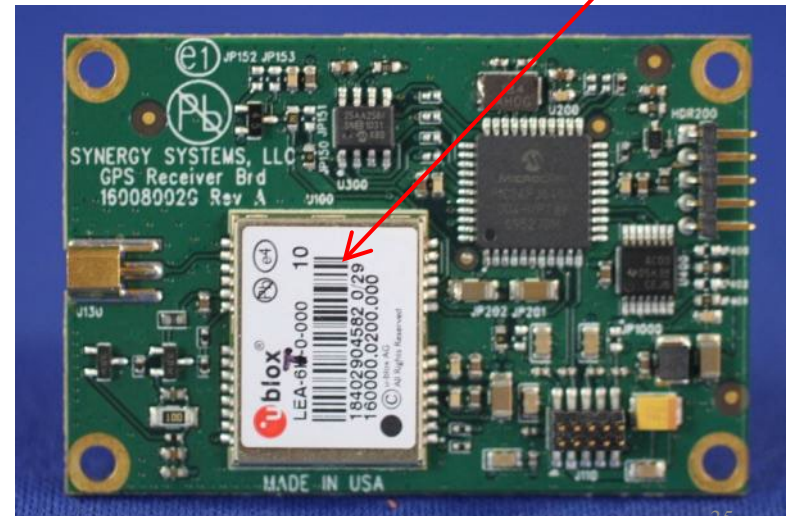

The 4 Receiver test @ GGAO:

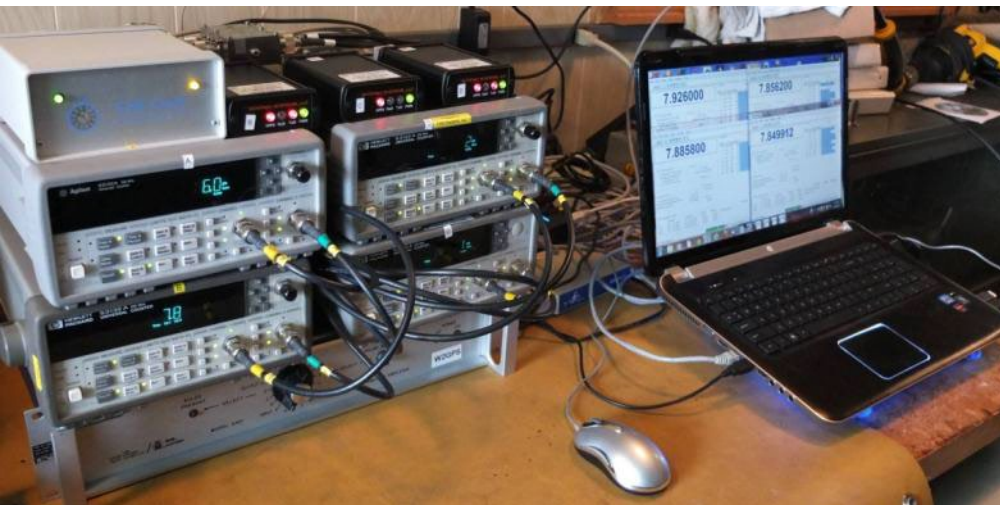

“Gold”
Motorola
M12+

iLotus
M12-M

Synergy LEA-
6Ts
uBlox uBlox
Moto Native
Emul. Cmds

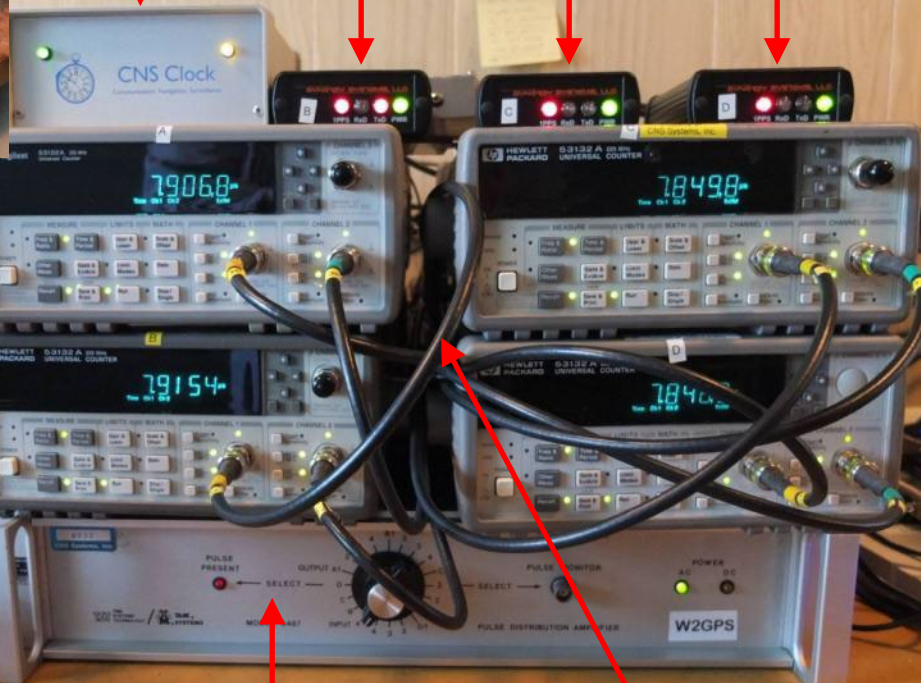

Maser
1PPS
Distributor

4@ HP53132
Counters 36



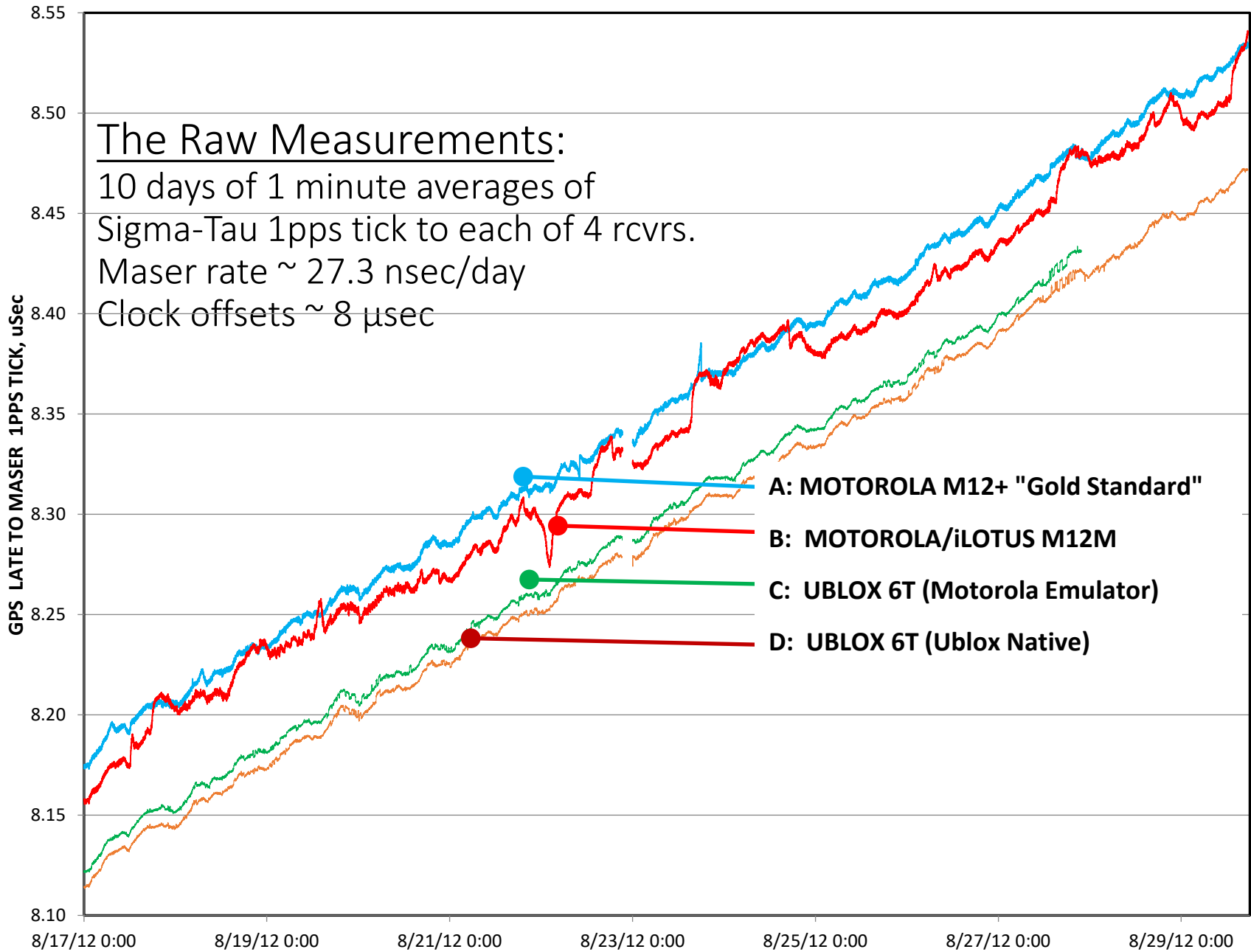

Removing 27.3 nsec/day H-Maser Rate

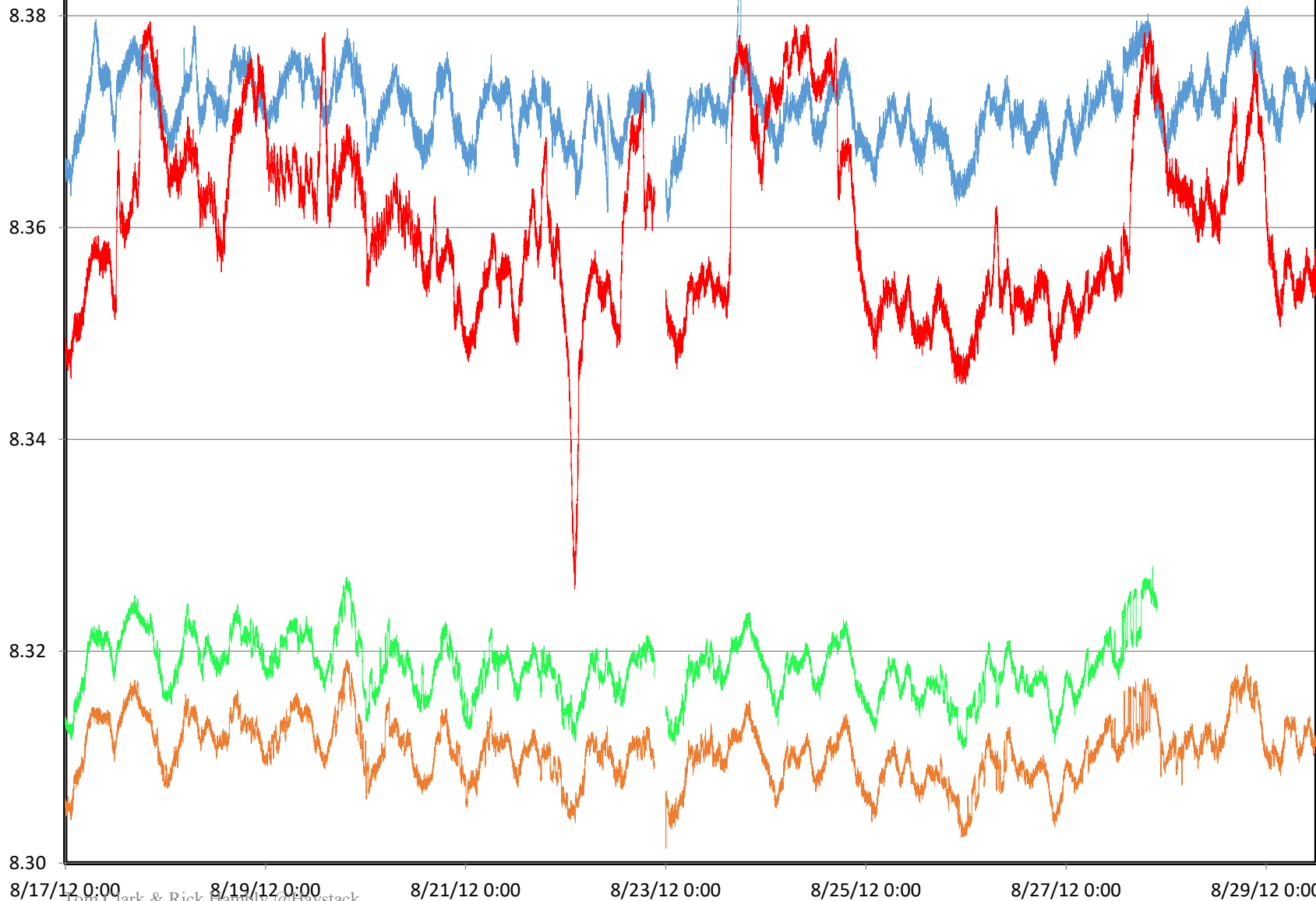

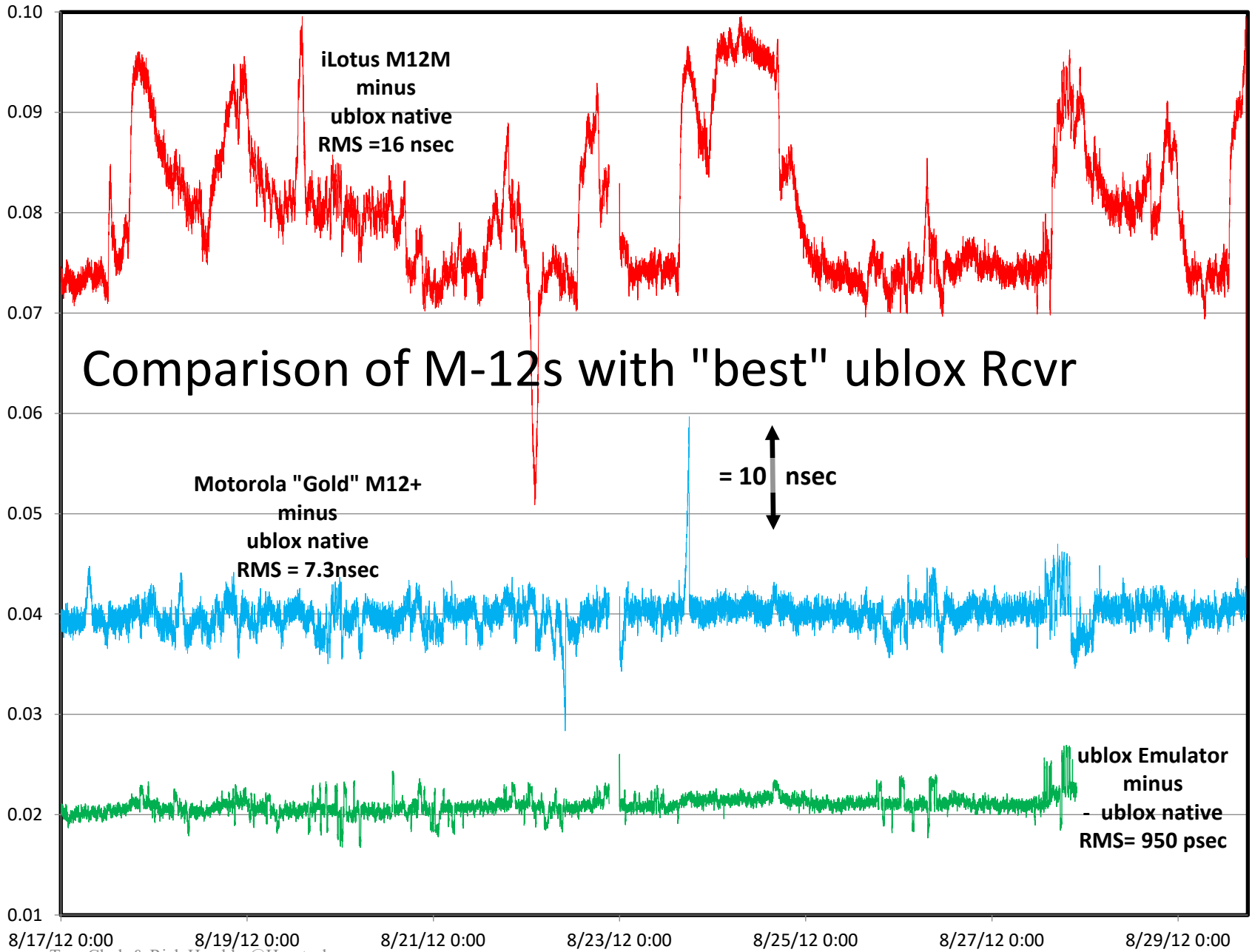

Modified Allan Deviation

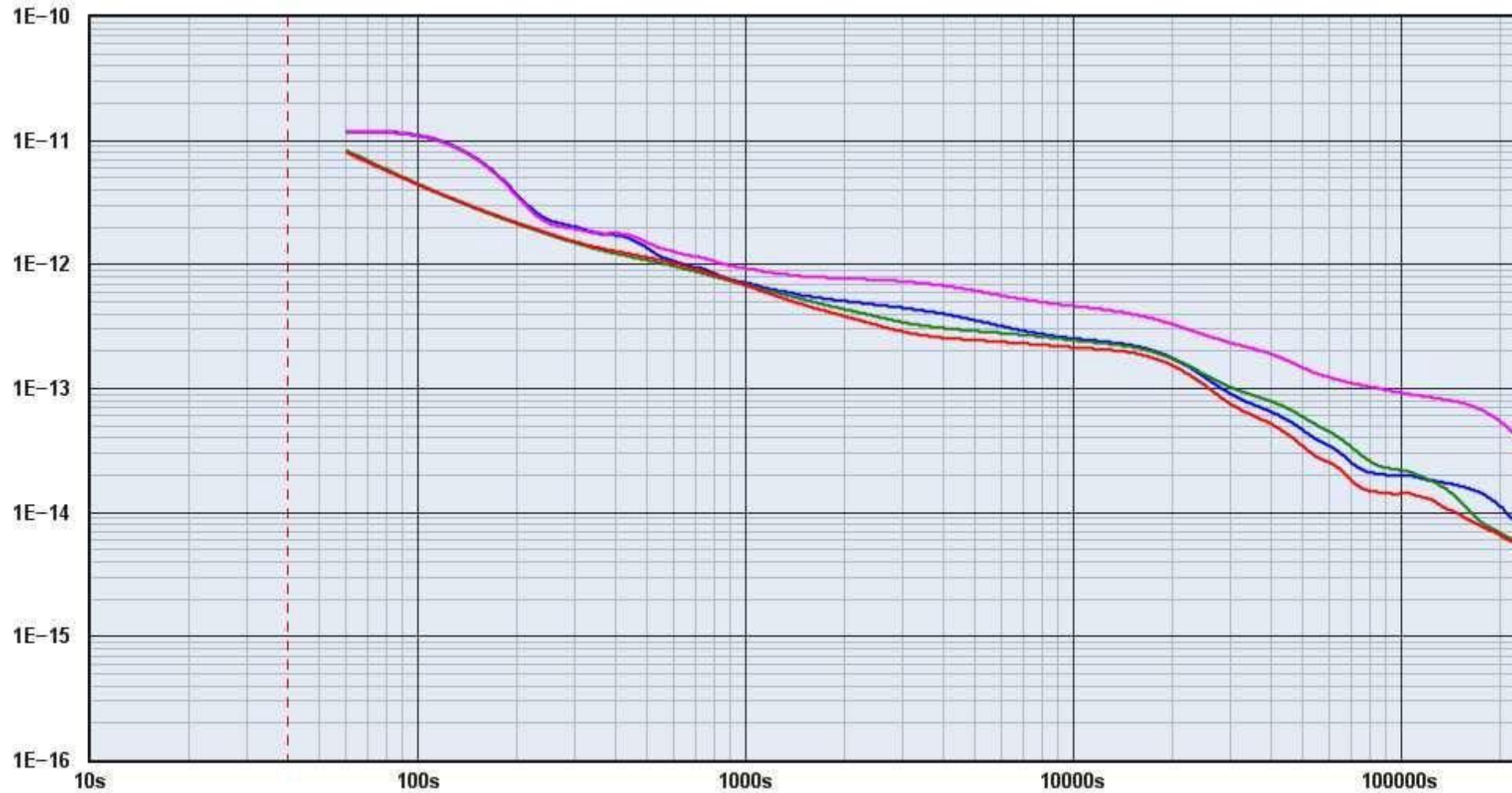

Trace	Notes	Filename	Pathname	Input Freq	Sample Interval	MDEV at 40s
GGAA_A (Unsaved)	Motorola "Gold" M12+			60 Hz	60 s	
GGAA_A (Unsaved)	iLotus M12M			60 Hz	60 s	
GGAA_A (Unsaved)	uBlox 6T, Motorola Emulator			60 Hz	60 s	
GGAA_A (Unsaved)	uBlox 6T, uBlox native			60 Hz	60 s	

Conclusions

1. Small, low cost GPS receivers can provide timing needed for VLBI anywhere in the world. This is not a new statement, it's been true since the 1990's! See www.gpstime.com for Tom's "Timing for VLBI" notes from the IVS TOWs for more details.
2. The current production iLotus M12M we tested showed jumps at the 10 nsec level. Some more M12M's need to be tested to see if this just a problem of this particular unit.
3. Even if (/when?) the Motorola/iLotus M12's become unavailable, the uBlox LEA6T can step in as a replacement.
4. Existing designs based on Motorola/iLotus M12s should have no problem in making the change to uBlox by using the Synergy M12 emulator. Ask Rick for details.
- 5. In fact, the uBlox we tested were a factor ~5 BETTER than the old M12's in all tests except for a "DC" bias ~30 nsec.**

More Obsolescence Problems

Agilent has announced “End-of-Life” for the 53131 and 53132 counters that have been the standard VLBI Time Interval Counter.

The 53131/132 has been very easy to use since it has an RS232 printer port that streams the readings. TAC32 was built around this capability.

Agilent is recommending the 53230A as their suggested replacement for the 131/132.

Berkeley Nucleonics offers their model Model 1104 as an alternative.

Both these counters suggest their use as “Net Appliances” on the station LAN using their Ethernet ports.

Tac32Plus v2.7.11 Now Supports Time Interval Counters via Ethernet.

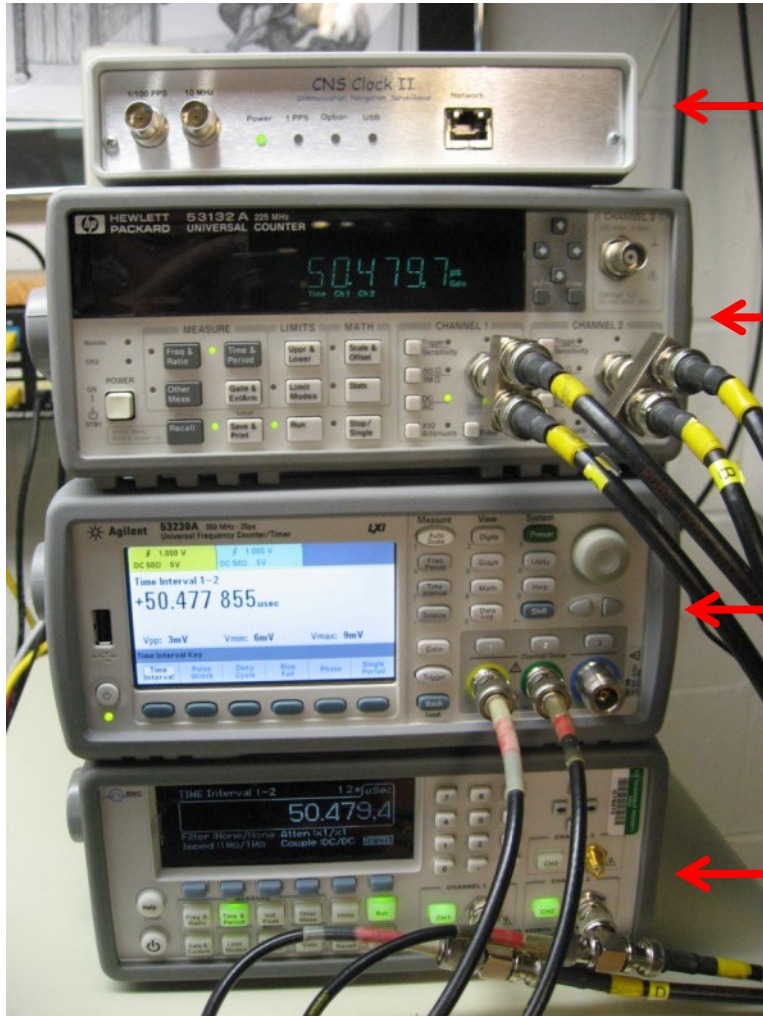

CNS Clock II
HP/Agilent
53132A
Serial Port

Agilent
53230A
Ethernet

Berkeley Nucleonics
Model 1104
Ethernet

The screenshot shows the Tac32Plus software interface with the following data:

- Time: 22:22:11.000
- UTC Time from GPS: UTC Day #232, 22:22:11.000, Thursday, 19 October 2012, GPS Week = 1710, UTC = GPS - 16 seconds
- PC Time: 18:22:10.980, Eastern Daylight Time, Latency: 0
- Sidereal Time: Local Mean Sidereal Time 17:41:17.78, Greenwich Mean Sidereal Time 00:13:23.54, Modified Julian Day 56218.93207
- Grid Square: FM19qc.71
- TIC (usec): 50.515200
- GPS Navigation Data: Latitude 39° 5' 25.2980", Longitude -76° 36' 14.8650", Alt(GPS) 15.95m, Alt(MSL) 50.06m, Avg: 39° 5' 25.1459", -76° 36' 14.8864", 17.09m, 51.20m, Ref: 30° 13' 13.3600", -98° 01' 26.3800", 309.33m, 332.23m
- Satellites table:

PRN	Ei	Azm	Eb/No	5	15	25	35
5	66	31	32				
29	55	288	29				
26	52	146	30				
2	45	98	33				
15	31	186	23				
10	13	58	22				
21	12	297	23				
25	9	245	0				
8	5	82	0				

9 Visible 8 Tracked
3-D Fix PDCP = 1.8

Tac32Plus V2.7.11

Note: GPS time vs.
HP5065A Rubidium CNS
Systems' time standard

Tac32Plus V2.7.11 Now Supports Time Interval Counters via Ethernet.

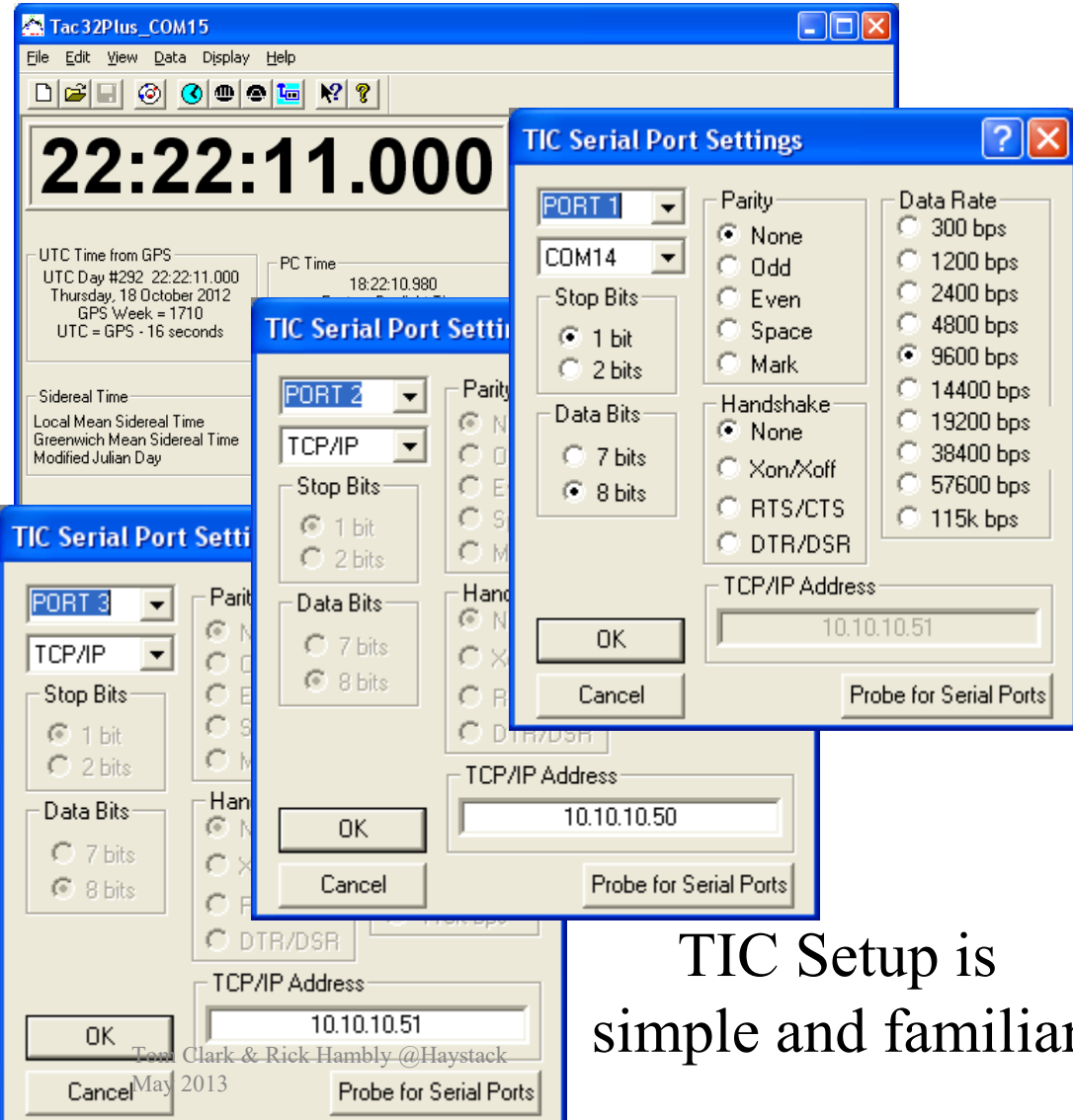

TIC Setup is simple and familiar

53132A vs.
BN1105

53132A vs.
53230A

Future TAC32 Enhancements:

- Next Generation CNS Clock II: Connect to CNS Clock II via TCP/IP
- uBlox SSR-6TR Receiver: Load new GPS firmware into the CNS Clock II
- Multi-platform versions
- Other enhancements based on user feedback.
- Contact Rick Hambly: rick@cnsys.com