

**It's About Time !!!!!**



# Timing for VLBI



□ **Tom Clark**

formerly at NASA Goddard Space Flight Center

With help from

□ **Rick Hambly**

**CNS Systems**

---

**IVS TOW Meeting**

**Haystack – Sept 21-24, 2003**

# What Timing Performance Does VLBI Need?

- The VLBI community (Radio Astronomy and Geodesy) uses Hydrogen Masers at 40-50 remote sites all around the world. To achieve  $\sim 10^\circ$  signal coherence for  $\sim 1000$  seconds at 10 GHz we need the two oscillators at the ends of the interferometer to maintain relative stability of  $\approx [10^\circ / (360^\circ \cdot 10^{10} \text{ Hz} \cdot 10^3 \text{ sec})] \approx 2.8 \cdot 10^{-15}$  @ 1000 sec
- To correlate data acquired at 16Mb/s, station timing at relative levels  $\sim 50$  nsec or better is needed. After a few days of inactivity, this requires  $\approx [50 \cdot 10^{-9} / 10^6 \text{ sec}] \approx 5 \cdot 10^{-14}$  @  $10^6$  sec
- In Geodetic applications, the station clocks are modeled at relative levels  $\sim 30$  psec over a day  $\approx [30 \cdot 10^{-12} / 86400 \text{ sec}] \approx 3.5 \cdot 10^{-16}$  @ 1 day
- Since VLBI defines UT1, we need to control  $[\text{UTC}_{(\text{USNO})} - \text{UTC}_{(\text{VLBI})}]$  to an accuracy  $\sim 100$  nsec or better.

# The difference between Frequency and Time

## Oscillators and Clocks

### Oscillator

- Pendulum
- Escapement Wheel
- Crystal Oscillator
- Oscillator Locked to Atomic Transition
  - Rubidium (6.8 GHz)
  - Cesium (9.1 GHz)
  - Hydrogen Maser (1.4 GHz)

### Integrator and Display = Clock

- Gears
- Electronic Counters
- Real Clocks

Events that occur  
with a defined

**FREQUENCY**

nsec -- minutes

Long-Term

**TIMING**

seconds - years

# The Allan Variance – A graphical look at clock performance

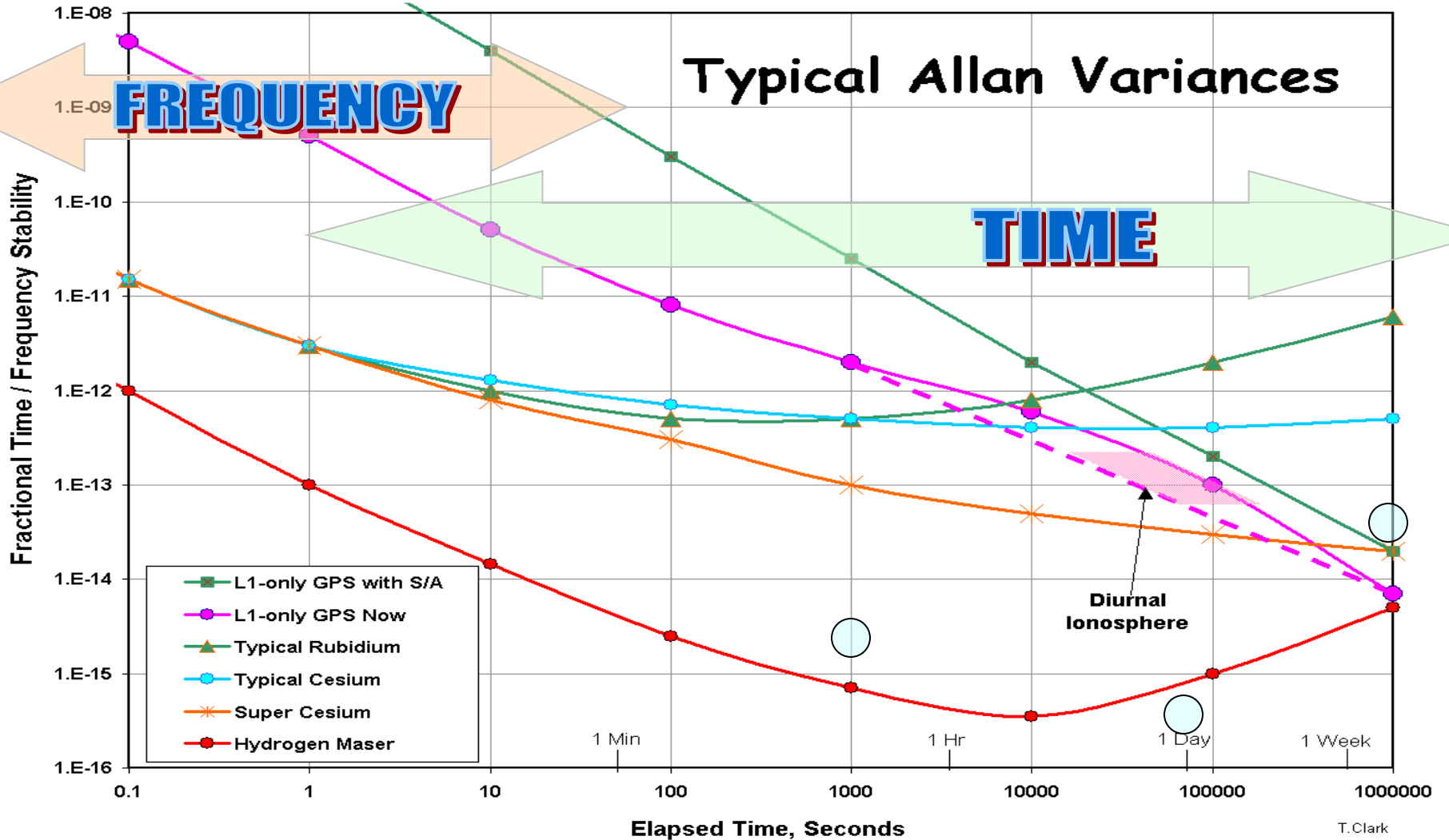

# **Why do we need to worry about “Absolute Time” (i.e. Accuracy) in VLBI?**



- To get the correlators to line up for efficient processing, the relative time between stations needs to be known to  $\sim 100$  nsec.
- The correlators maintain their “magic tables” that relates the GPS timing data reported by different stations to each other.
- In the past, geodetic and astronomical VLBI data processing has been done by fitting the data with “station clock polynomials” over a day of observing, and then discarding these results as “nuisance parameters” that are not needed for determining baseline lengths, source structure, etc.
- The uncalibrated and unknown offsets now range from 1-10 usec at many VLBI stations.

# Why do we need to worry about “Absolute Time” (i.e. Accuracy) in VLBI?



- The ***ONLY*** reason for worrying about “absolute time” is to relate the position of the earth to the position of the stars:
  - Generating Sidereal Time to point antennas.
  - Measuring UT1 (i.e. “Sundial Time”) to see changes due to redistribution of mass in/on the earth over long periods of time.
  - Knowing the position of the earth with respect to the moon, planets and even the the GPS satellites.

# **Why do we need to worry about “Absolute Time” (i.e. Accuracy) in VLBI?**



**At the stations this means that we will need to pay more attention to timing elements like**

- Frequency Standard and Station Timing**
- The lengths of cables**
- The geometry of the feed/receiver to the antenna.**
- Calibration of instrumental delays inside the receiver and backend. The development of new instrumentation is needed.**
- The care with which system changes are reported to the correlators and the data analysts.**



# VLBI's "REAL" Clocks (1)

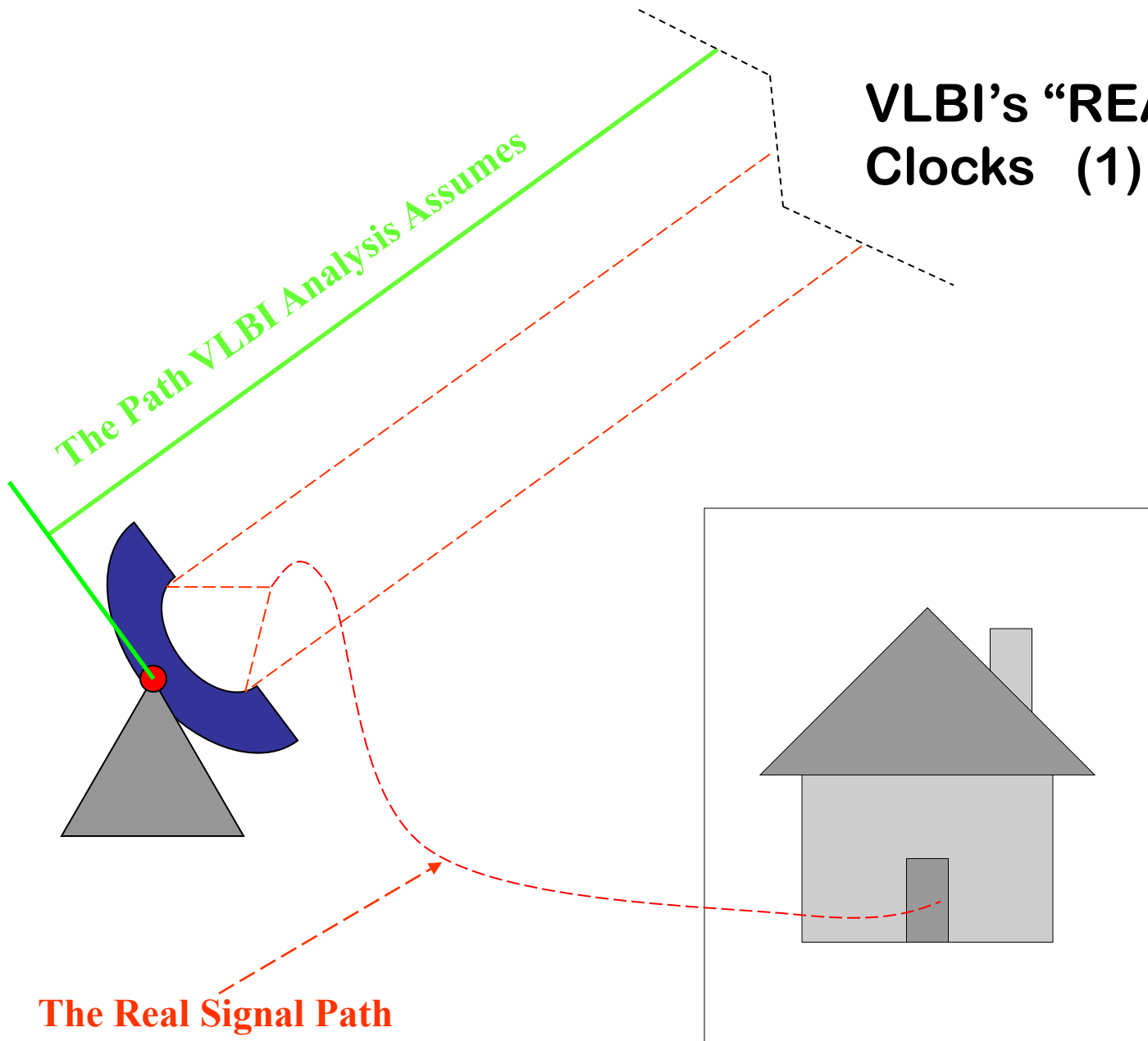

**The Real Signal Path**

# VLBI's "REAL" Clocks (2)

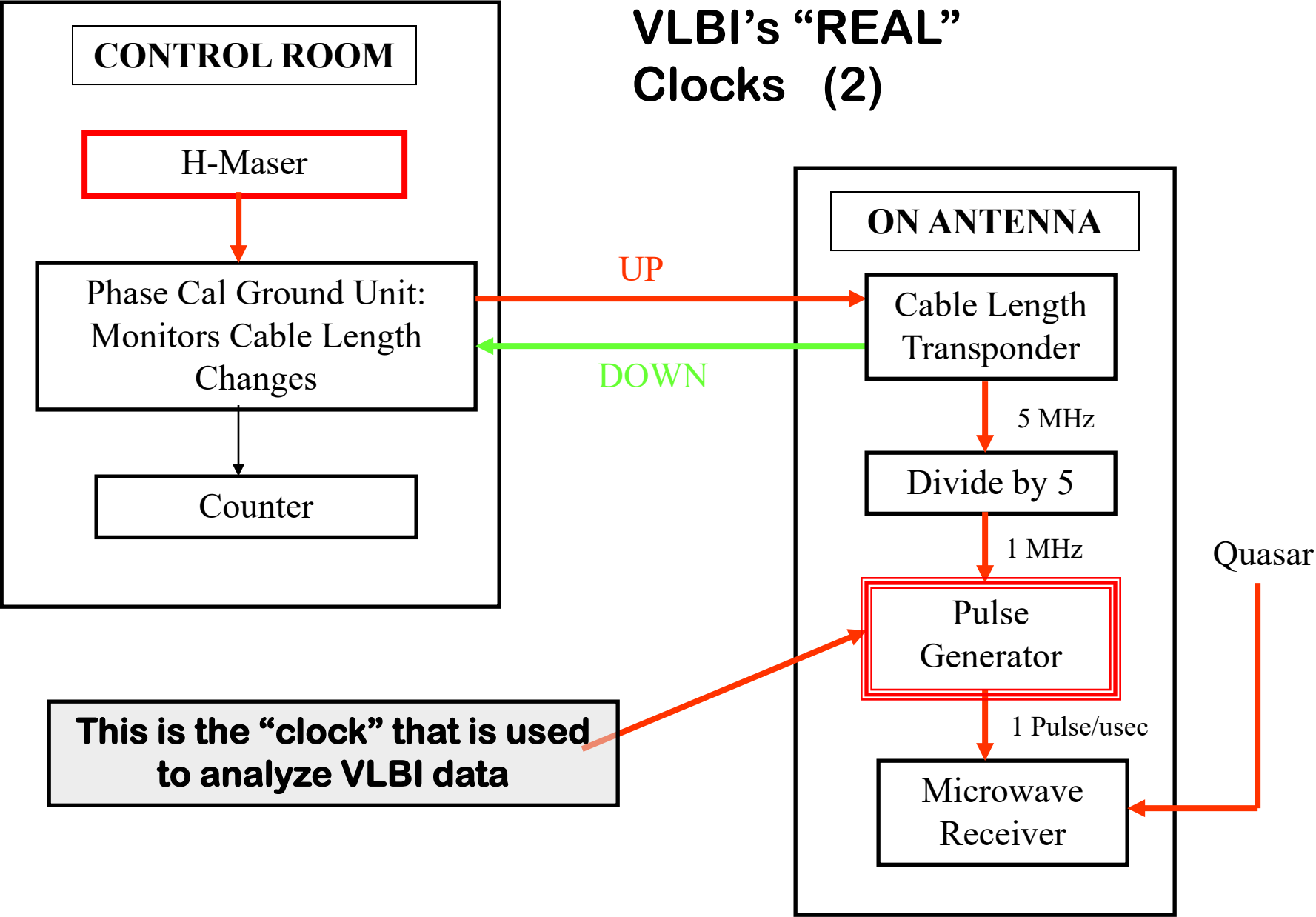

# VLBI's "REAL" Clocks (3)

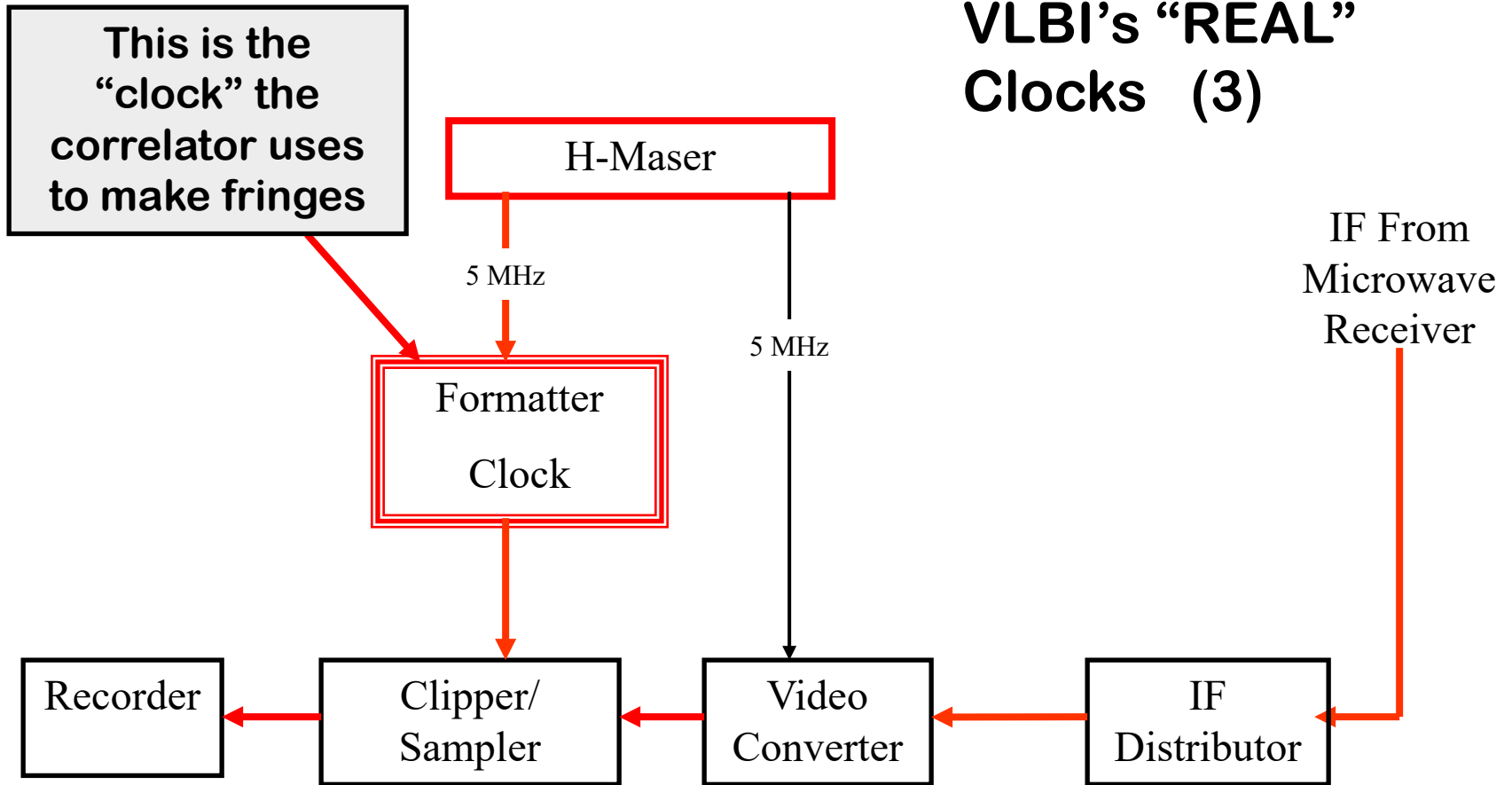

# Setting VLBI Clocks Time & Rate with GPS

## -- 3 possible ways--

- ⊗ Compare two distant clocks by observing the same GPS satellite(s) at the same time (called Common View)
  - Requires some intervisibility between sites
  - Requires some near-Real-Time communication
  - Links you directly to the “Master Clock” on the other end at ~1 nsec level
- ⊗ Use Geodetic GPS receivers (i.e. as an extension of the IGS network)
  - Requires high quality (probably dual frequency) receiver (TurboRogue, Z12, etc), but it’s hard to gain access to the internal clock.
  - Requires transferring ~1 Mbyte/day of data from site
  - Requires fairly extensive computations using dual-frequency data to get ~300 psec results with ionosphere corrections
  - Allows Geodetic community to use VLBI Site for geodesy & ionosphere network

 **Blindly use the Broadcast GPS Timing Signals as a clock**

- **Single Frequency L1 only (until 2004)**
- **Yields ~10 nsec results with < \$1000 hardware**

# An Isolated, Remote VLBI Site -- Urumqi in Xinjiang Province, China



Urumqi's 6-channel  
NASA-built TAC



Urumqi's Chinese  
H-Maser

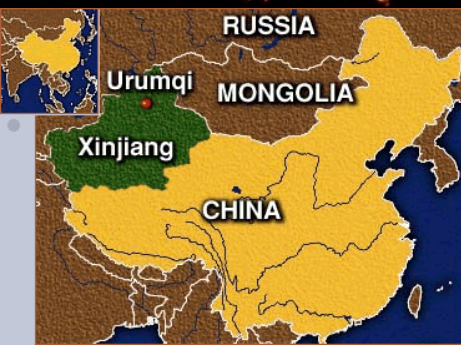

An Early Example of "Blind" GPS Timing with a 6 channel receiver

# ONSALA H-Maser vs "TAC" GPS

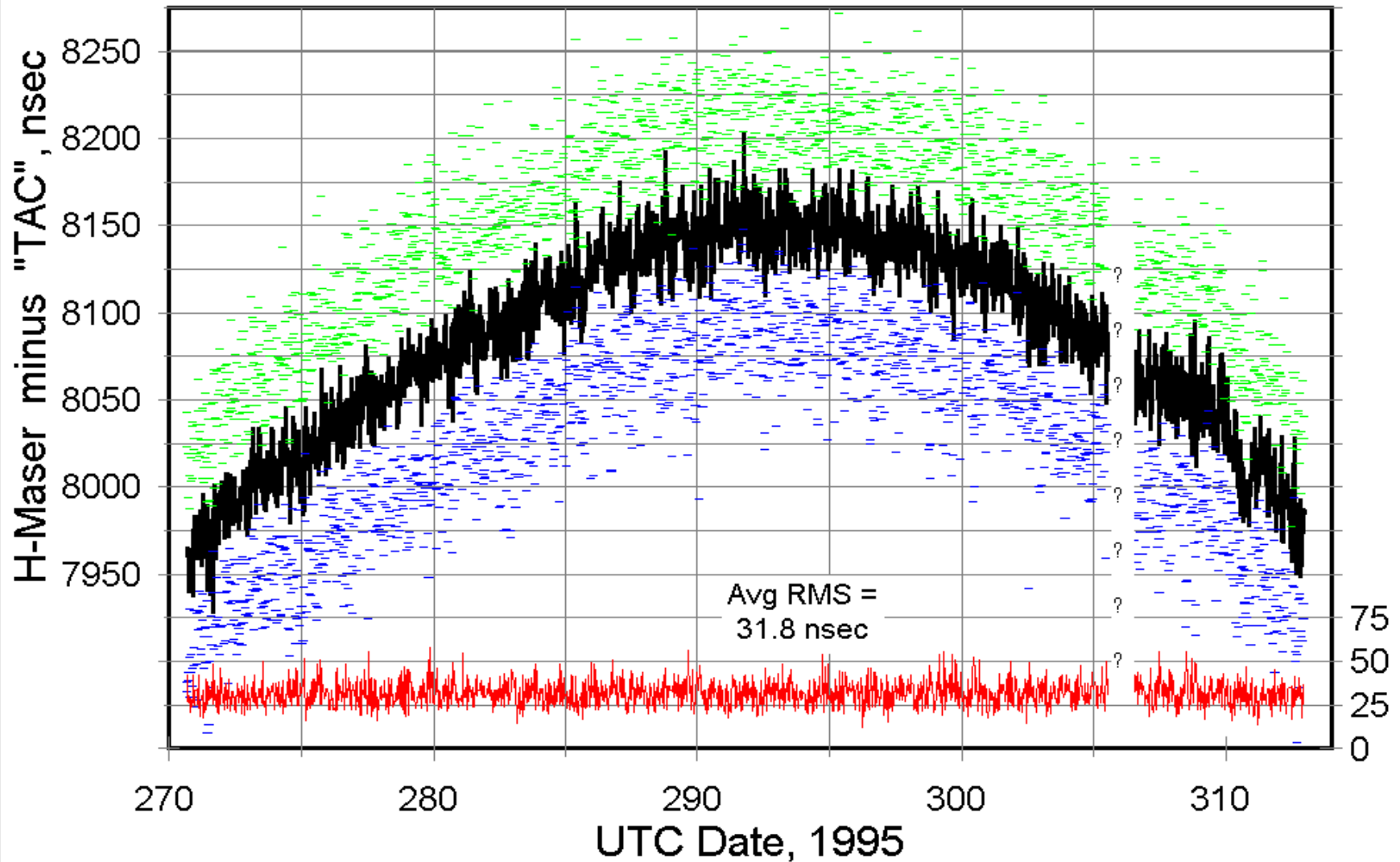

# Before S/A was turned off (8-channel) . . .

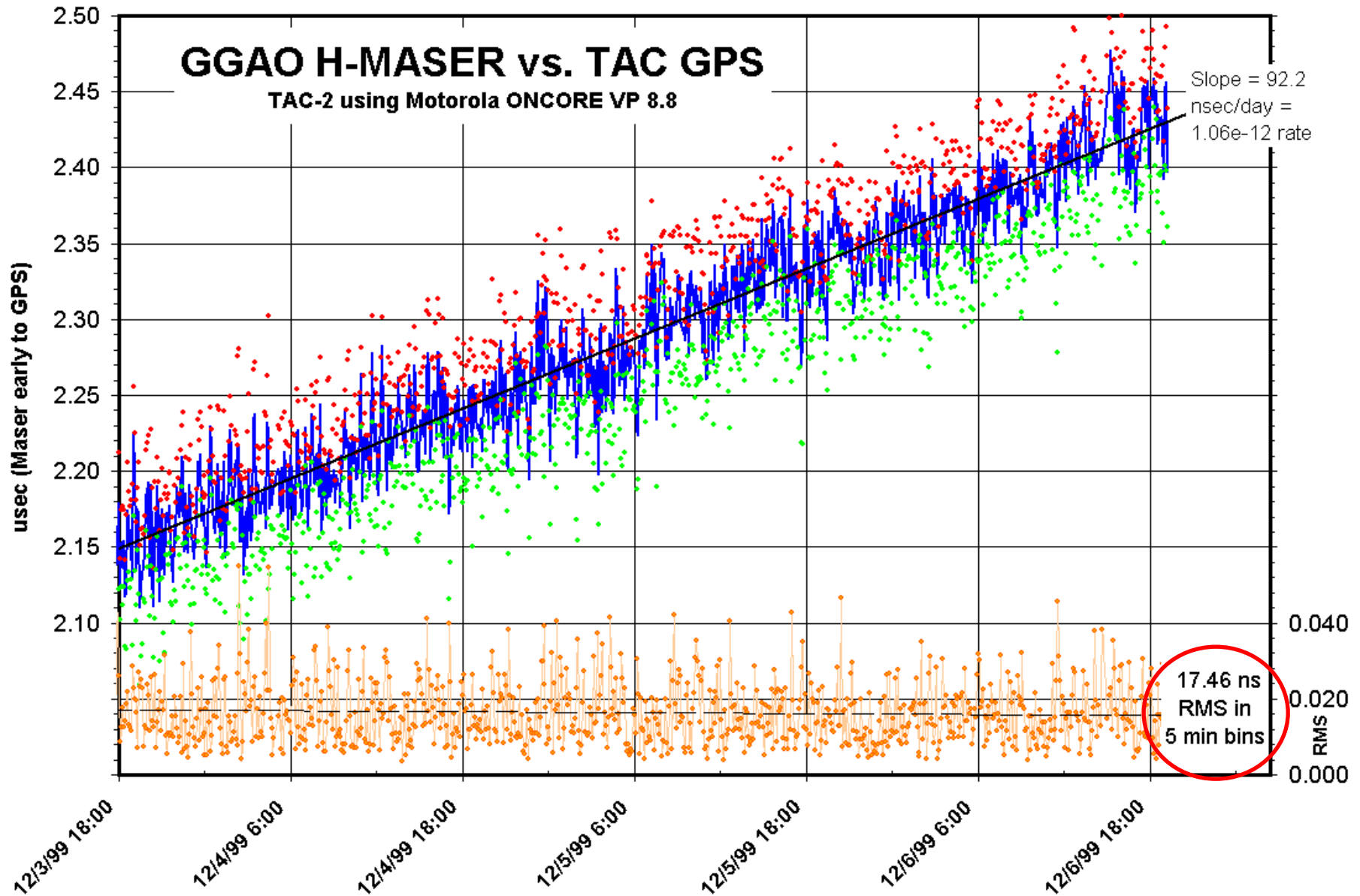

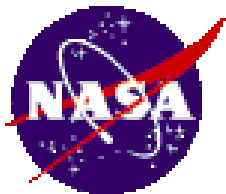

# **GGAO** (Goddard Geophysical & Astronomical Observatory)

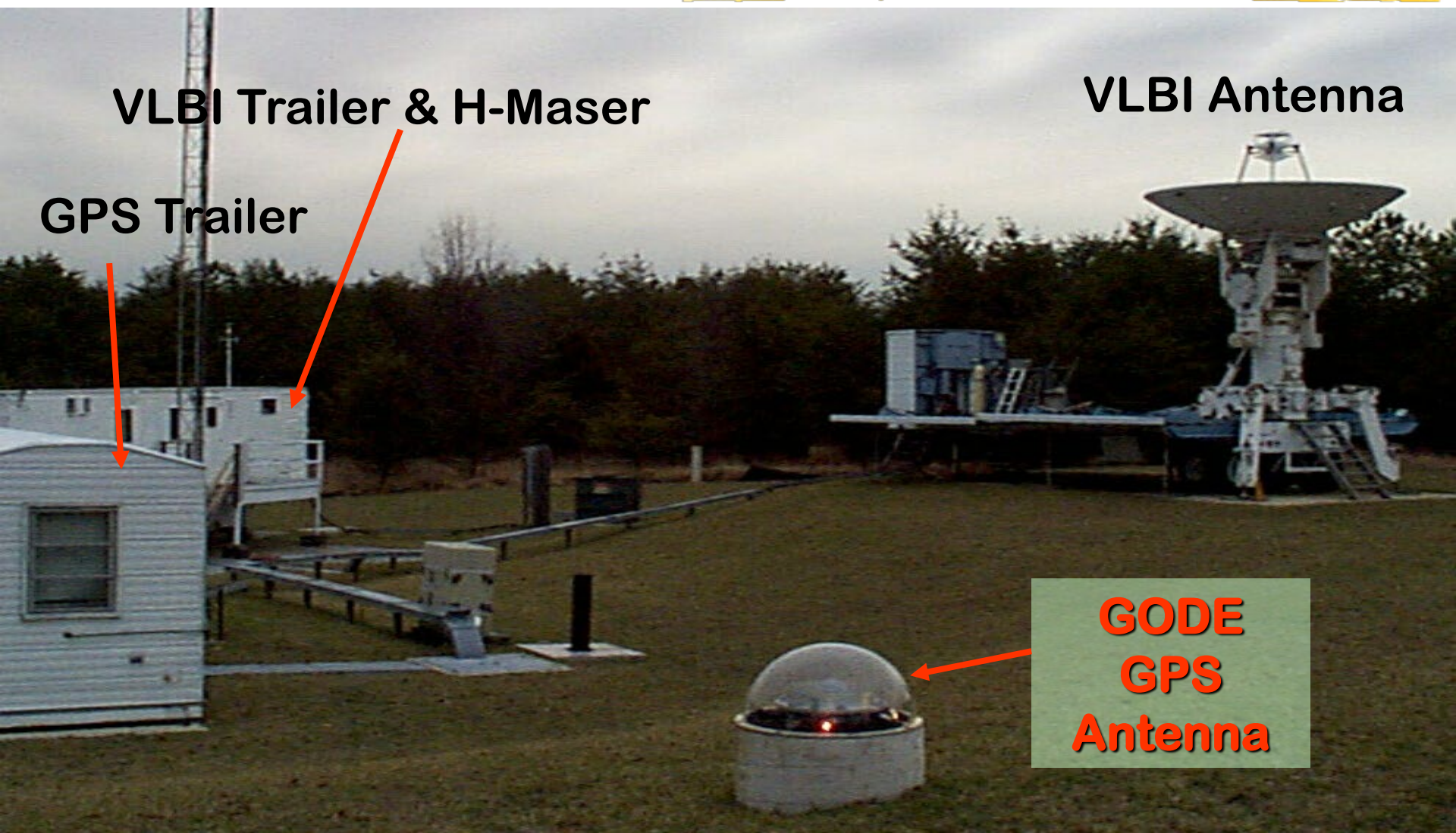

**VLBI Trailer & H-Maser**

**GPS Trailer**

**VLBI Antenna**

**GODE  
GPS  
Antenna**



# How we got ~30 nsec timing even with S/A



- Start with a good timing receiver, like the Motorola ONCORE
  - Average the positioning data for ~1-2 days to determine the station's coordinates. With S/A on, a 1-2 day average should be good to <5 meters. Or if the site has been accurately surveyed, use the survey values.
  - Lock the receiver's position in "Zero-D" mode to this average.
  - Make sure that your Time-Interval Counter (TIC) is triggering cleanly. Start the counter with the 1 PPS signal from the "house" atomic clock and stop with the GPS receiver's 1PPS.
  - Average the individual one/second TIC reading over ~5 minutes.
- 
- These steps were automated in the SHOWTIME and TAC32Plus Software.

TIC = Time Interval Counter  
TIC-TAC = TIC plus TAC

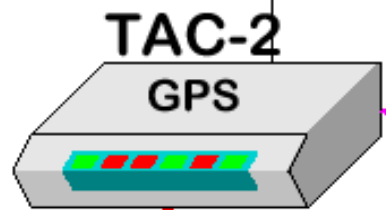

START  
STOP

GPS 1PPS

TIC-TAC PC Provides via the LAN:  
✓ Logged Timing Data by FTP  
✓ Counter Readings by Telnet  
✓ Station Epoch Time by XNTP

INITIAL SYNC

Maser 1PPS

Maser 5MHz

5 MHz to Mk4 Rack  
and to Rcvr Front End

Normal Station  
Time-Interval Counter



START  
STOP

IEEE488 I/O

Mk4 Field System  
on LINUX PC

H-Maser

Formatter

1PPS SYNCH

Formatter 1PPS OUT

Recommended  
Clock and Timing  
Setup for a  
Mark4 VLBI Station



STATION'S TCP/IP LAN

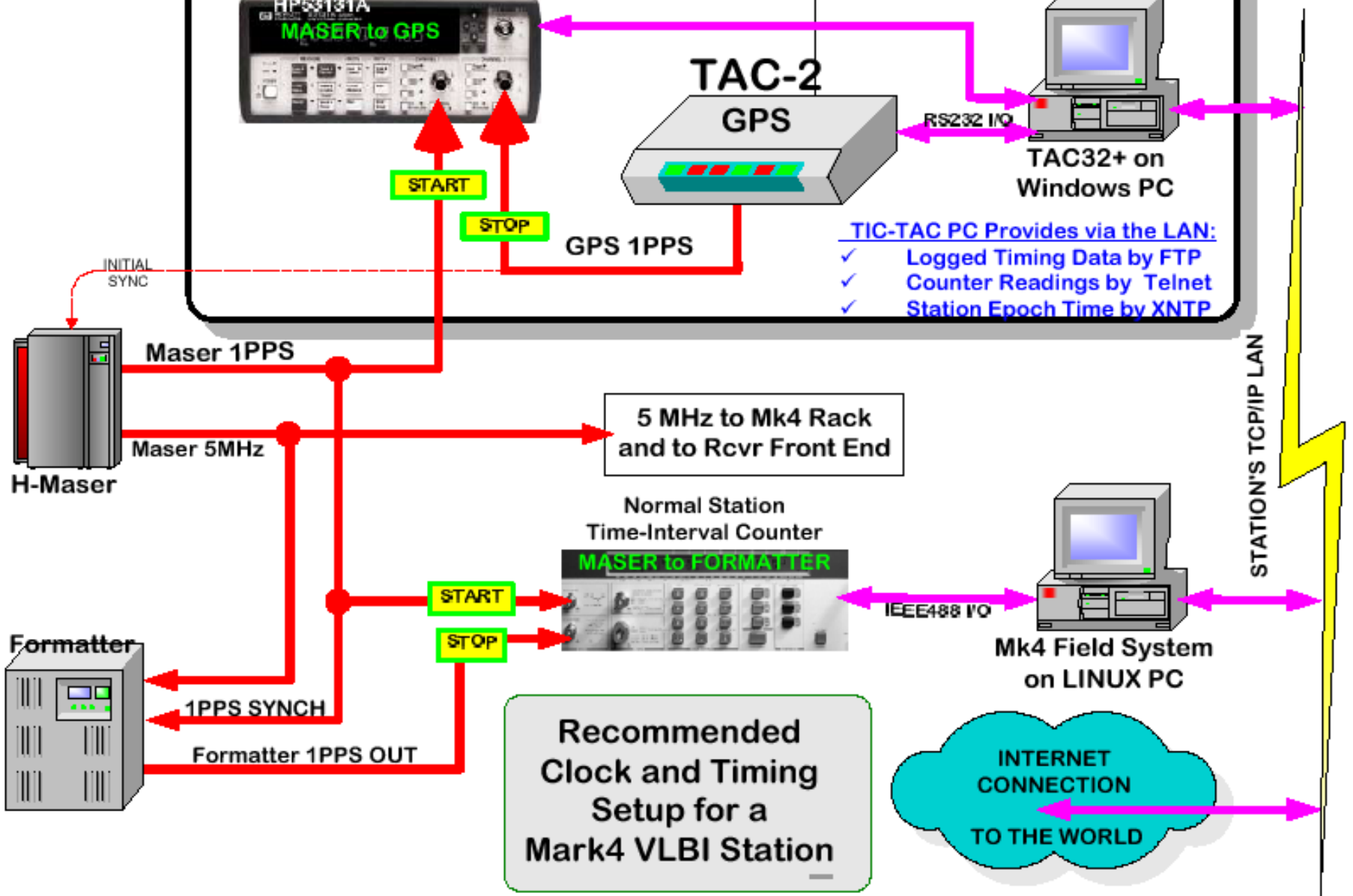

# Let Us Now Discuss . . .



- **What happened when S/A was turned off on May 2<sup>nd</sup>, 2000.**
- **Sawtooth and Glitches**
- **Some recent results obtained with Motorola's newest low cost timing receiver (the M12+)**

# What happened when S/A went away?

Using 8-channel Motorola ONCORE VP Receiver . . .

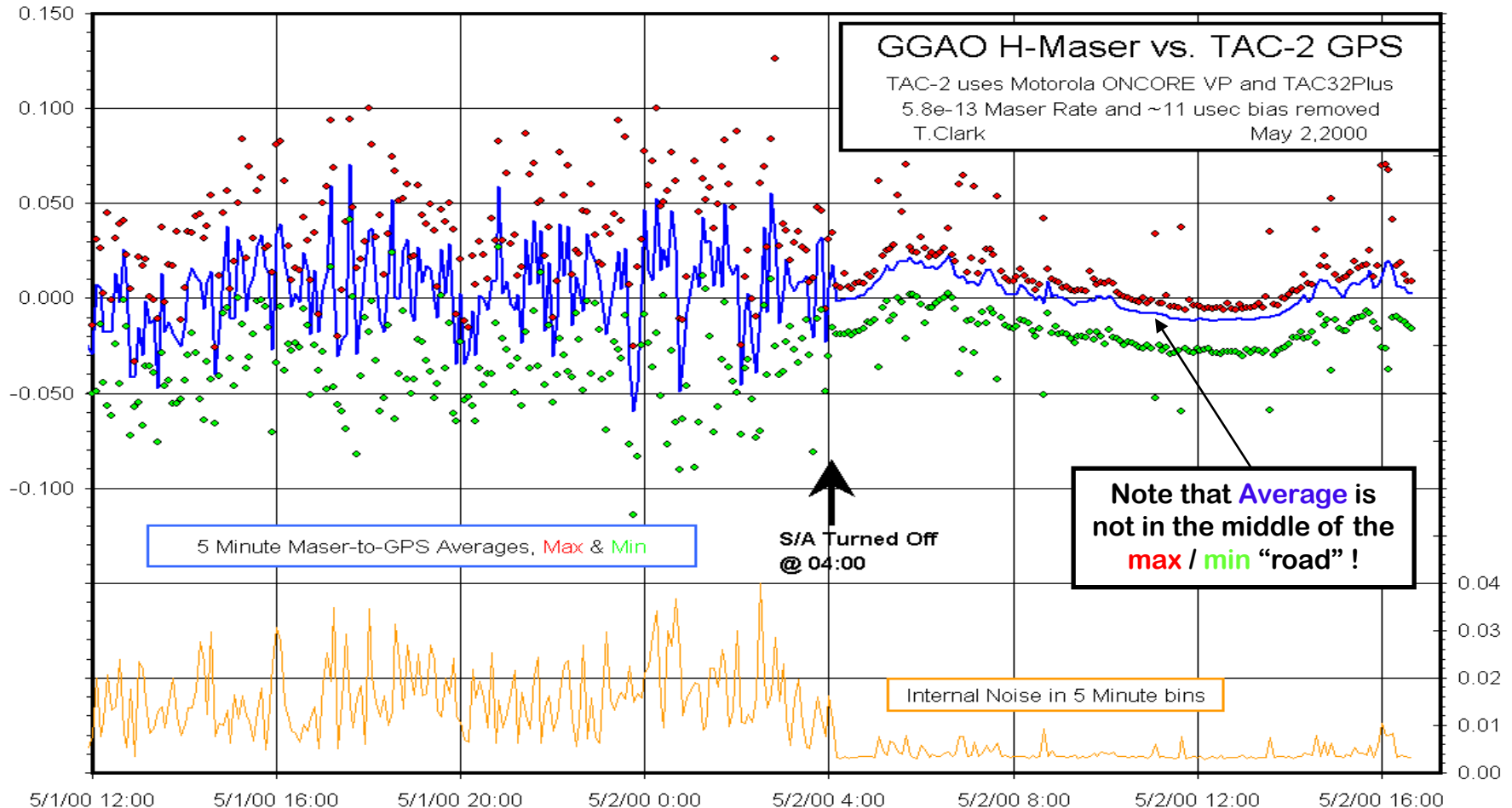

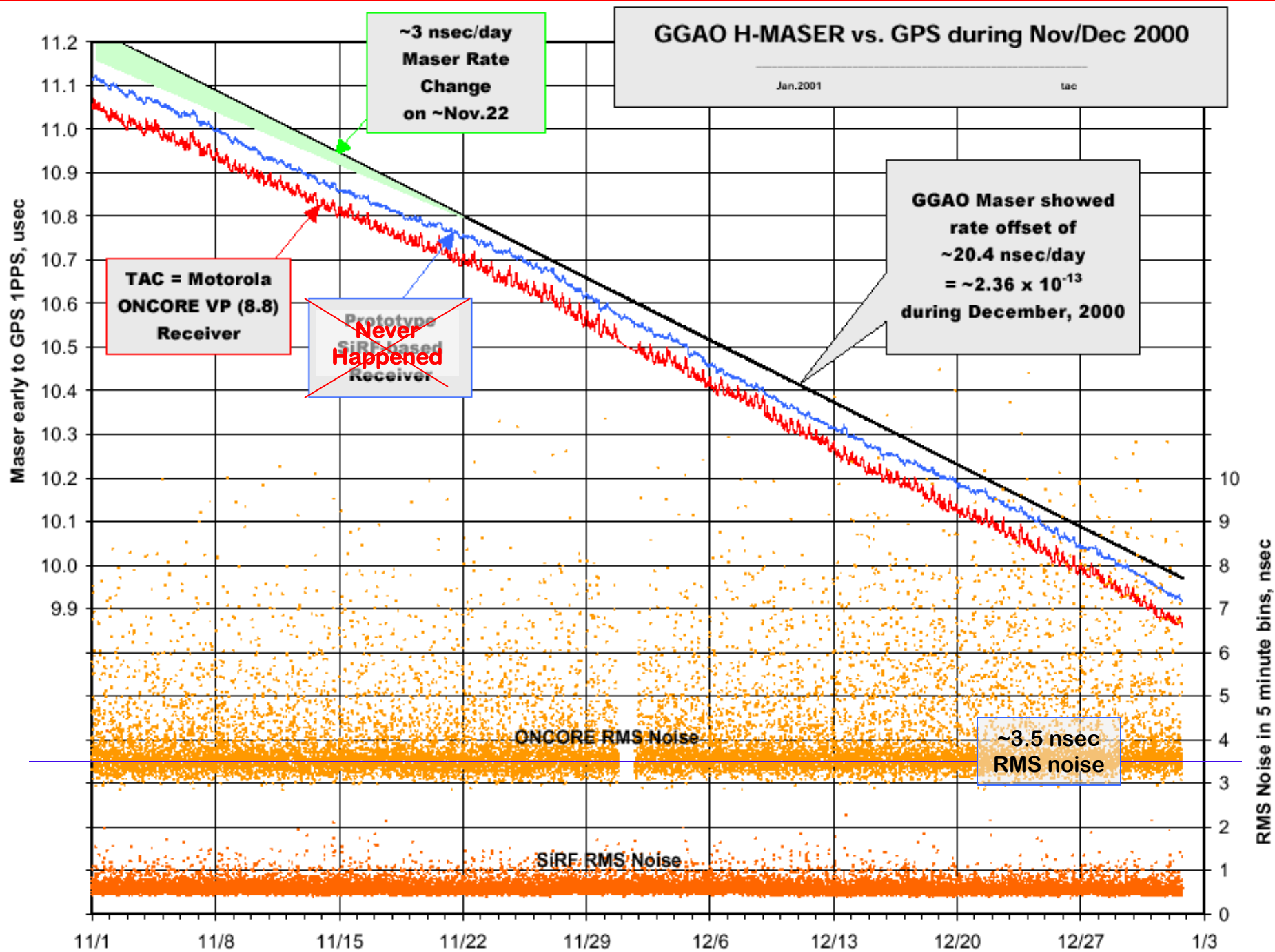

# What is the sawtooth effect ????

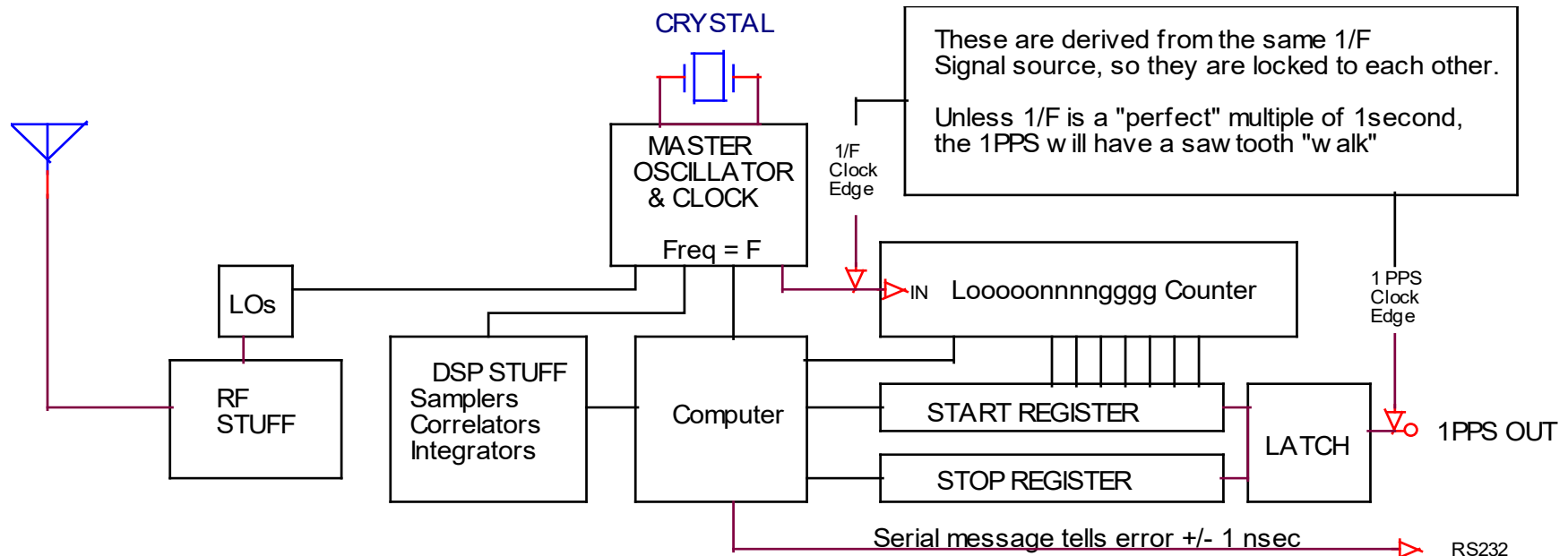

- For the older Oncore,  $F=9.54$  MHz, so the  $1/F$  sawtooth has a range of  $\pm 52$  nsec (104 nsec peak-to-peak)
- The new Oncore M12+ has  $F \approx 40$  MHz, so the sawtooth has been reduced to  $\pm 13$  nsec (26 nsec).

# An example of 1PPS sawtooth

## Motorola VP (10.0)

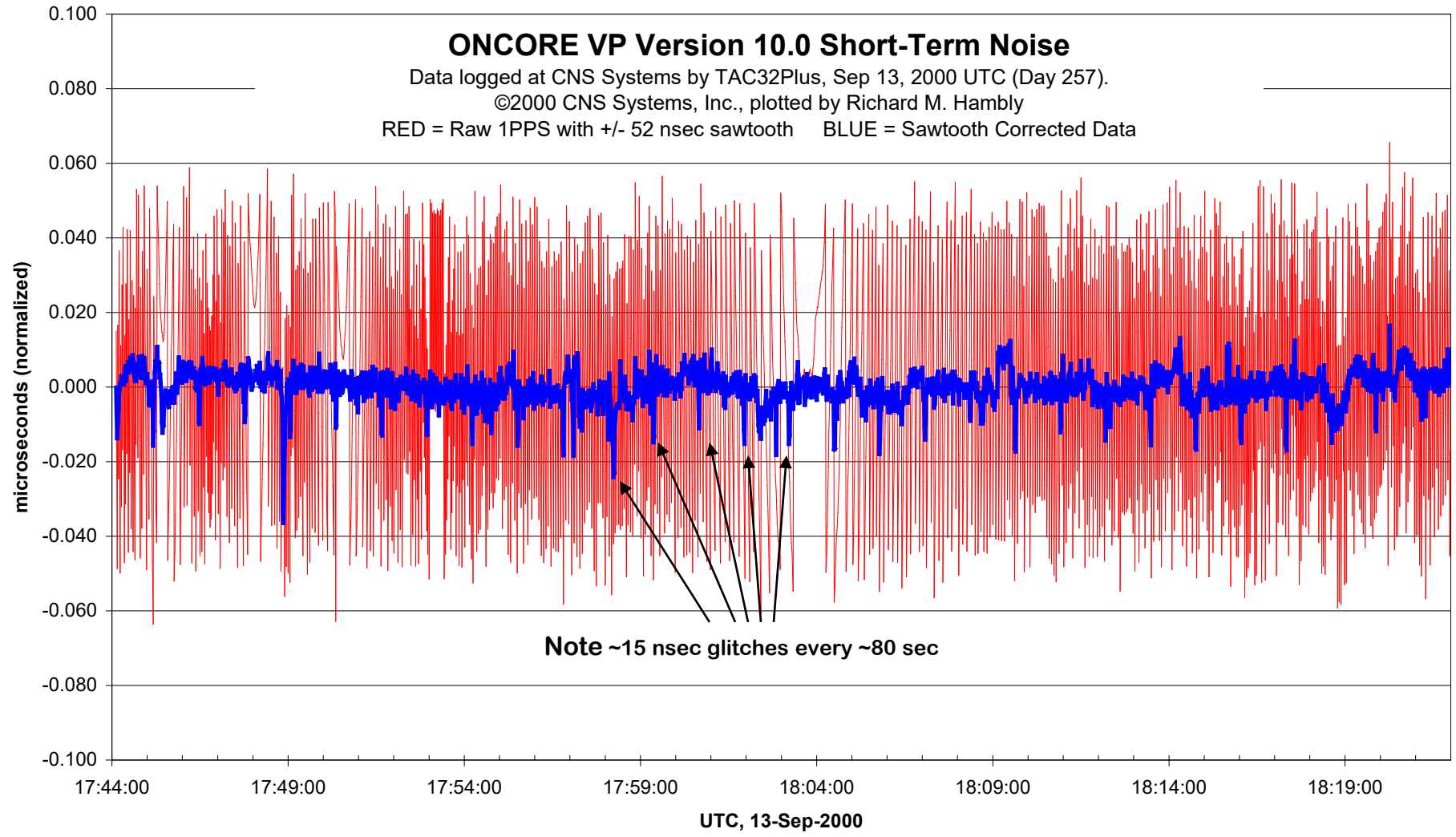

# An example of 1PPS sawtooth

## Motorola UT+ (3.1)

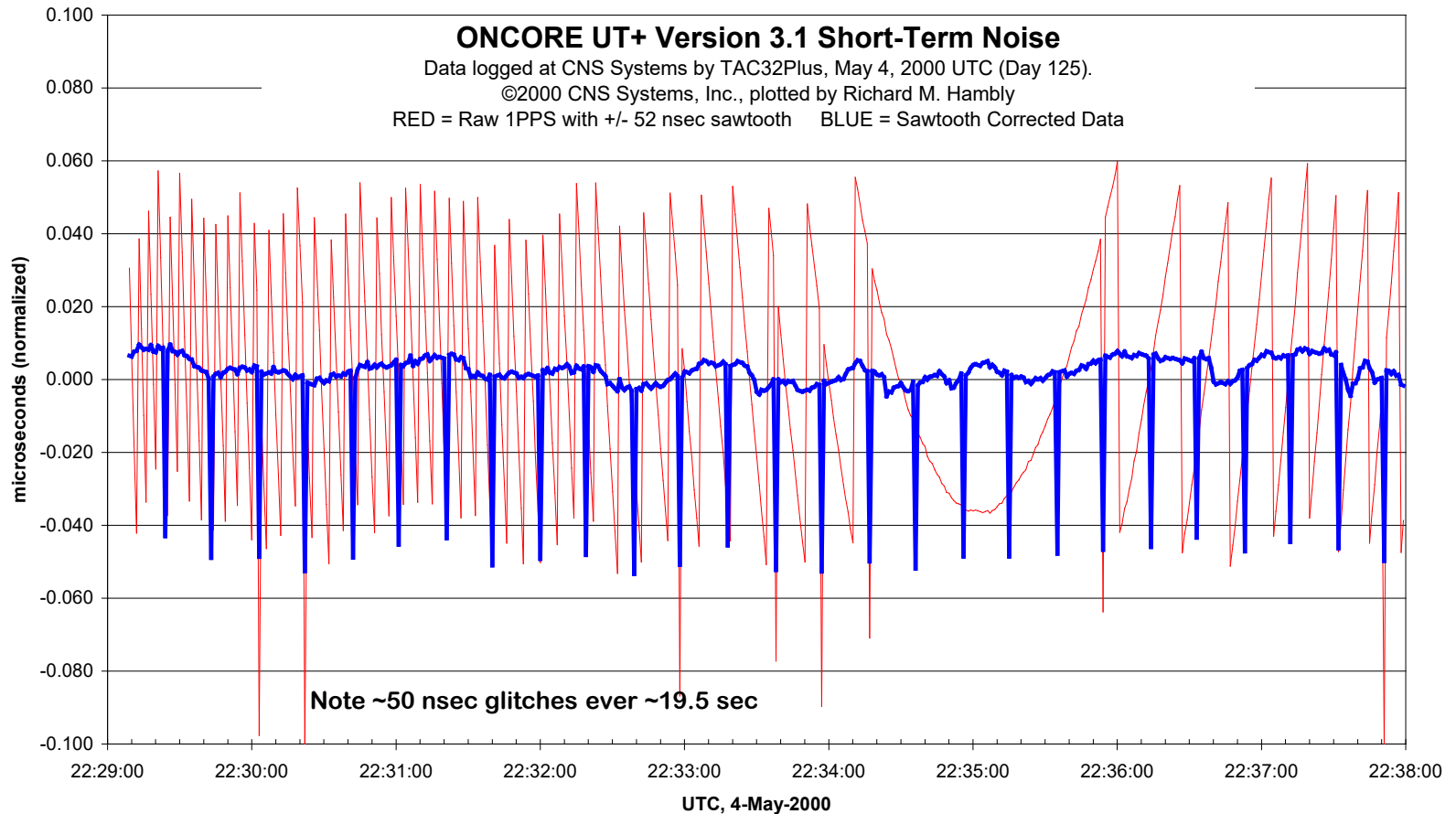



# CNS Systems' Test Bed at USNO

Calibrating the “DC” Offset of the new M12+ receiver.

We have observed that the ONCORE firmware evolution from 5.x  $\Rightarrow$  6.x  $\Rightarrow$  8.x  $\Rightarrow$  10.x has been accompanied by about 40 nsec of “DC” timing offsets.

Motorola tasked Rick to make the new M12+ receiver be correct.



Tac32Plus software simultaneously processes data from four Time Interval Counters and four CNS Clocks, writing 12 logs continuously.

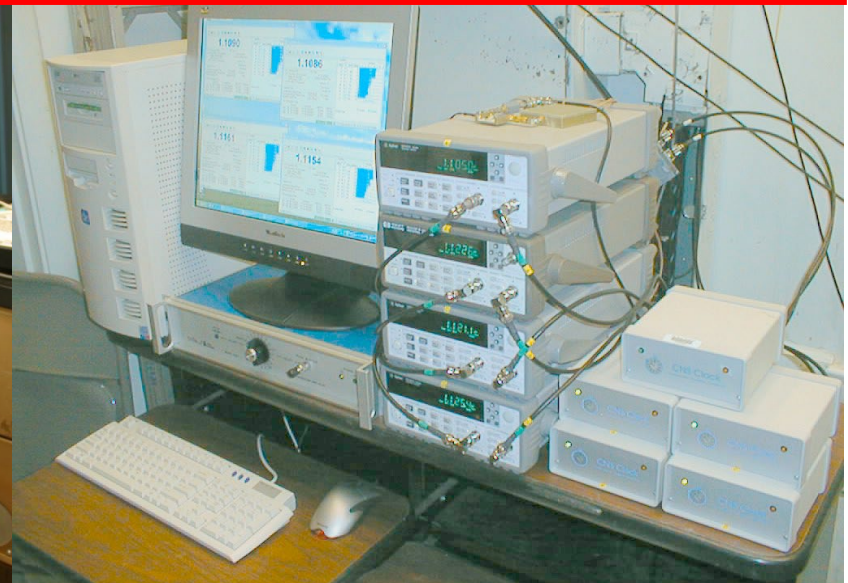

Time Interval Counters compare the 1PPS from each CNS Clock (M12+) against the USNO's UTC time tick.

# An example of 1PPS sawtooth with the new Motorola M12+ receiver

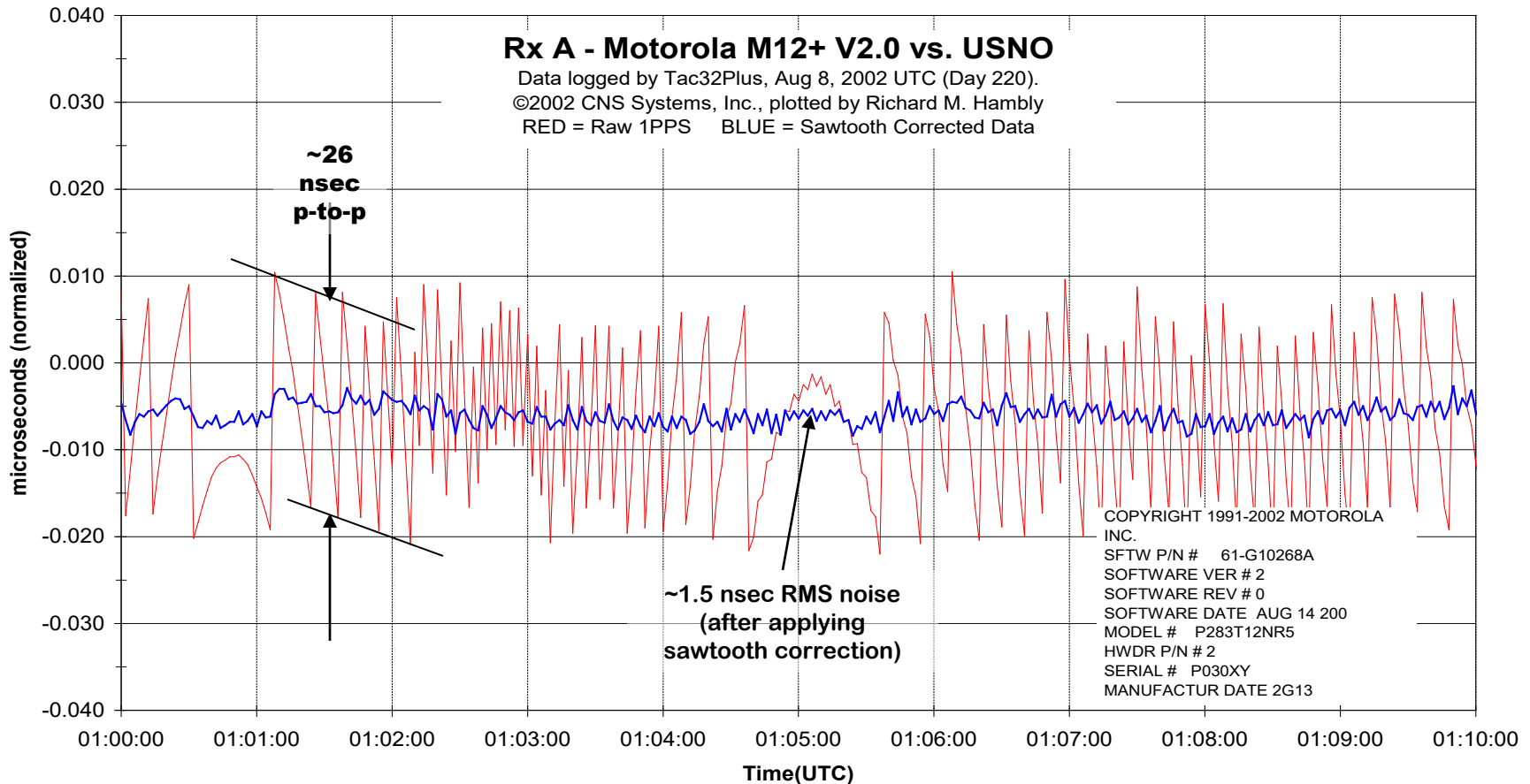

# How could the sawtooth be eliminated ???

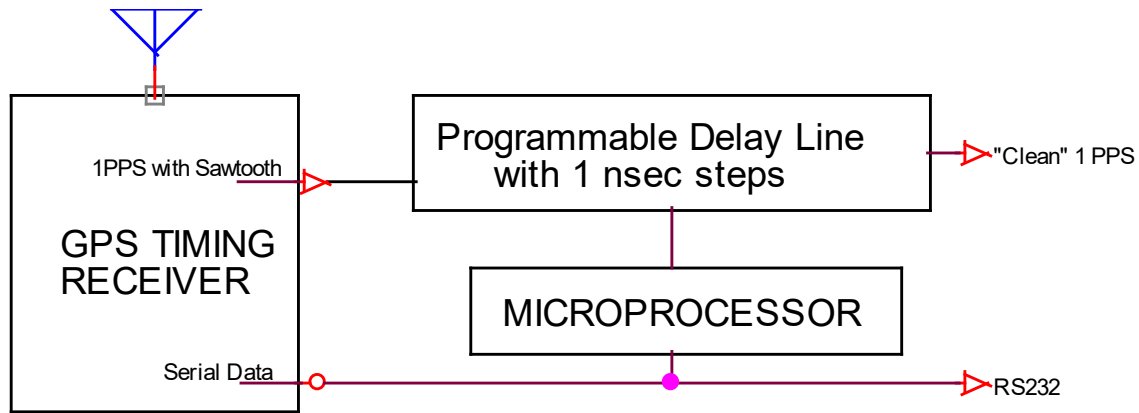

A POSSIBLE WAY TO ELIMINATE THE ANNOYING SAWTOOTH

Stay tuned for this! Talk to Rick,

# Individual M12 Clock Performance

Receiver (A) average "DC" offset = -0.6 ns

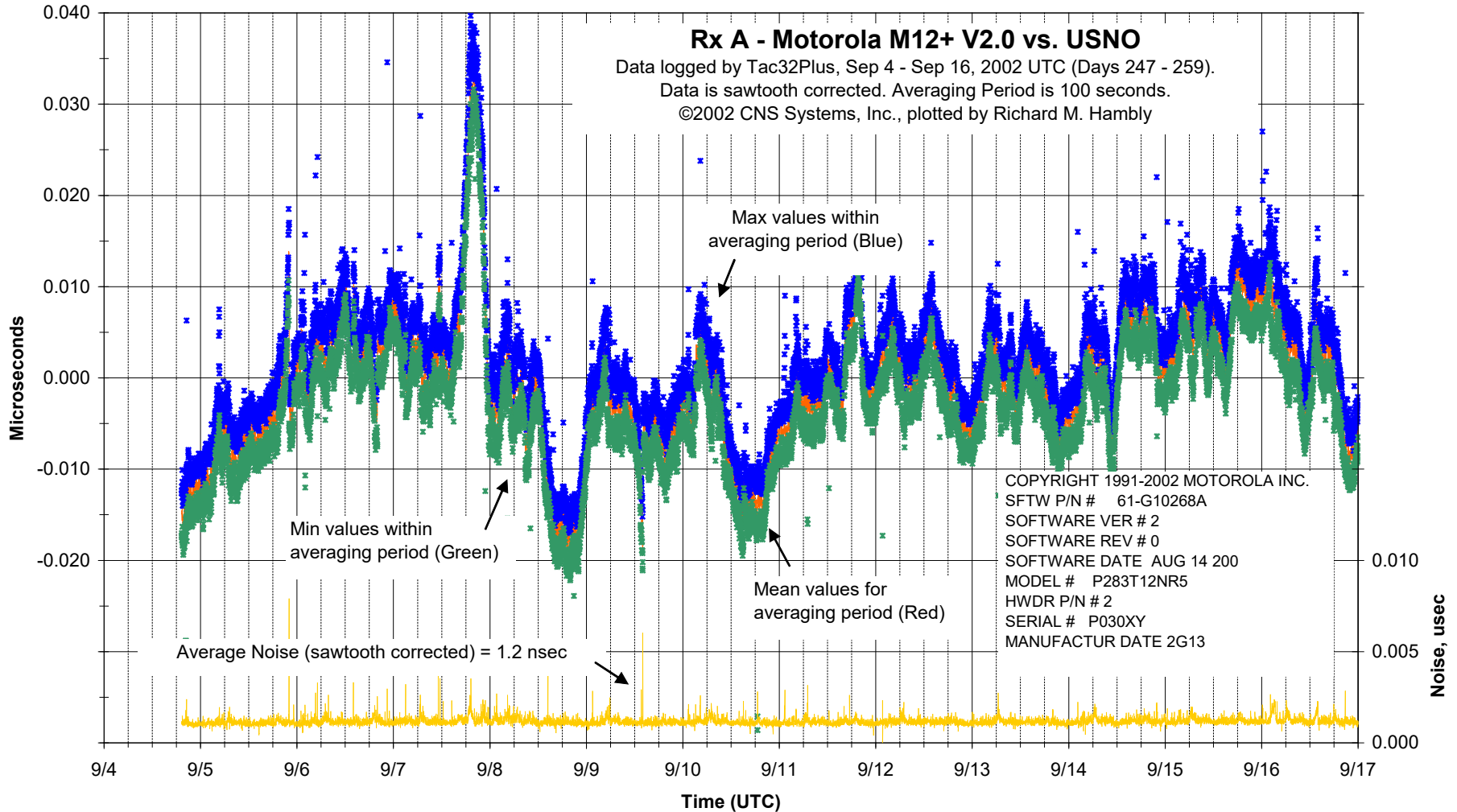

# Comparing four M12+ Timing Receivers

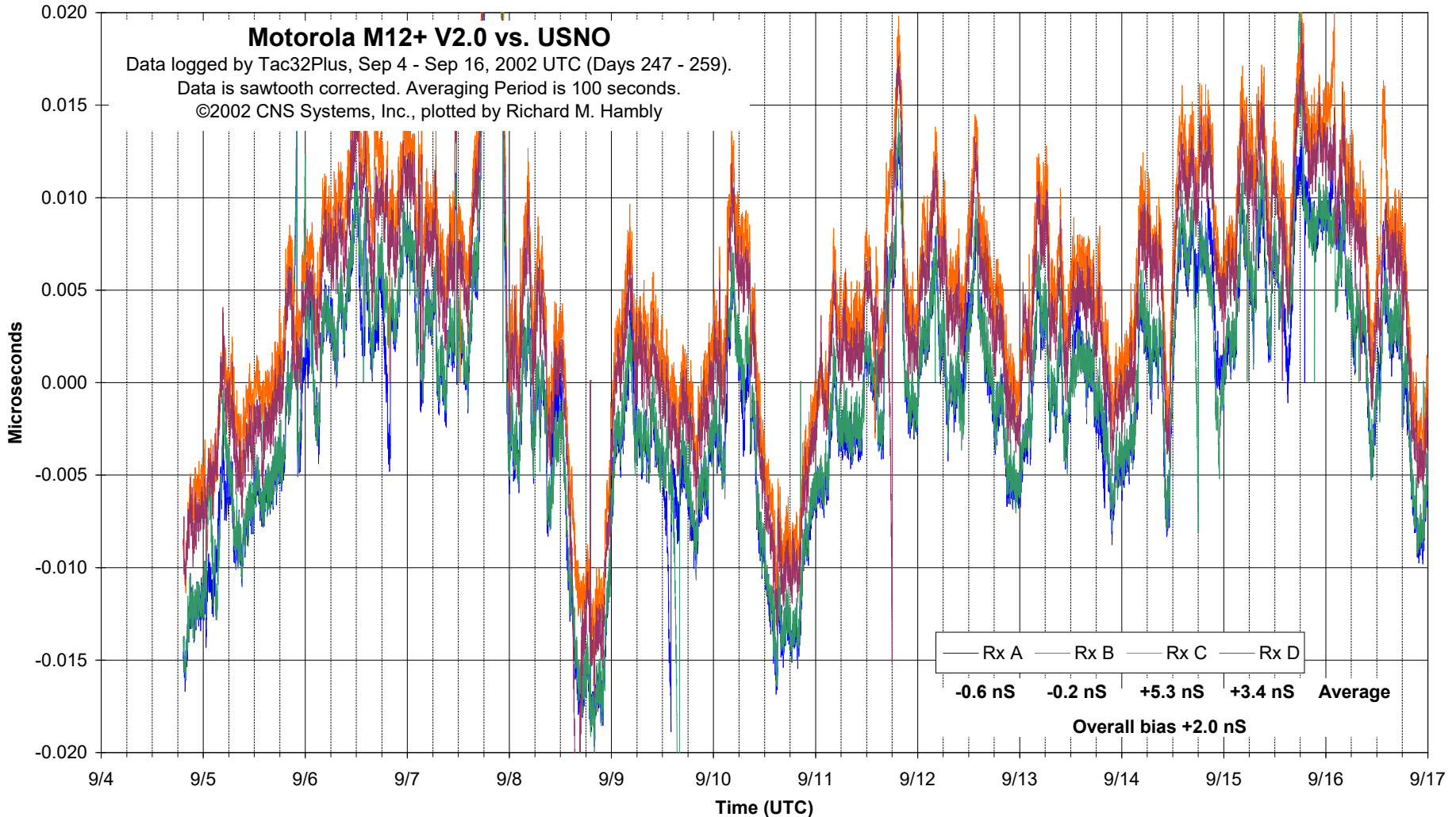

# What Happened on 9/7/02 ?



September 7, 2002.

This picture is a two hour composite of 85 different photos spanning 21:07 thru 23:10 EDT on Sept. 7th (01:07 thru 03:10 UTC Sep. 8).



September 8, 2002.

This picture is a four hour composite of 140 different photos spanning 20:00 thru 24:00 EDT on Sept. 8th (00:00 thru 04:00 UTC Sep. 9).

Each picture was an 87 second exposure with 3 seconds between frames. The trails on the picture are all due to airplanes. The bright loop is from a plane on final approach into BWI airport. Camera = Canon D60 shooting Hi Resolution JPEG at ISO 100 with TC-80 timer. Lens = Sigma f/2.8 20-40 mm set to 20 mm @ f/4.5

# Short Baseline Test (USNO to NASA GGAO)

Comparing two new Motorola M12+ GPS Timing Receivers over the 21.5 km baseline between the US Naval Observatory (USNO) and the NASA Goddard Geophysical & Astronomical Observatory (GGAO).

Both data sets compare the GPS timing receiver to a local Hydrogen Maser clock. On both, a linear fit to remove constant clock offset and drift has been applied.

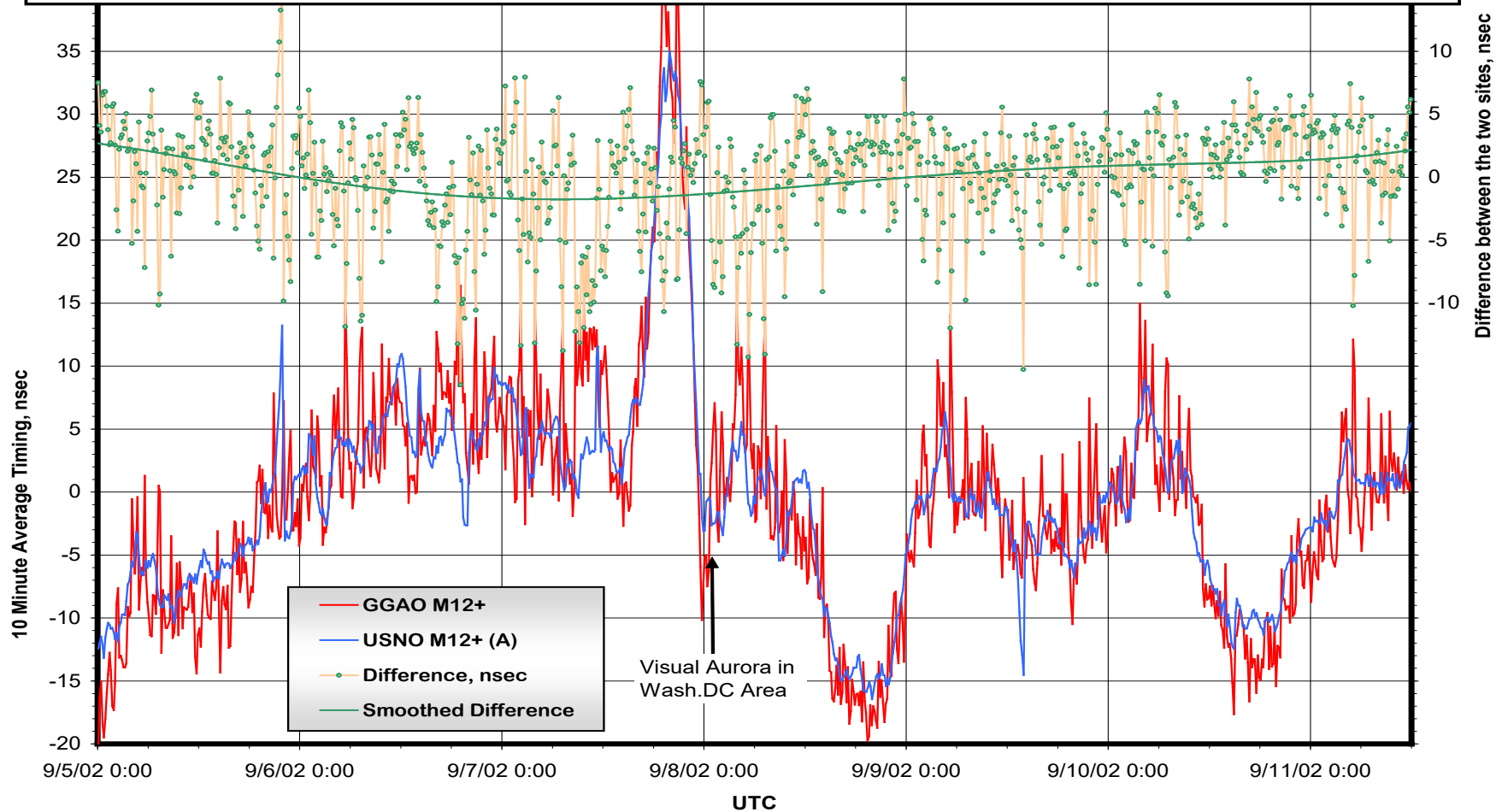

# Where to get information?



These Slides and related material and our Salt Lake City ION 2000 paper:

<http://gpstime.com>

Information on Rick Hambly's CNS Clock, a commercial clone of my TAC-2:

<http://www.cnssys.com>

For ONCORE/TAC-2 receiver used as a LINUX xntp server:

<http://gpstime.com>

To contact me:

<mailto:w3iwi@toad.net>

To contact Rick:

<mailto:rick@cnssys.com>





# Some TAC32Plus Screens in Windows 2000

## APPENDIX A

# TAC32Plus: DISPLAYS UTC TIME

**Tac32Plus**

File Edit View Data Display Help

17:15:36.000

UTC Time from GPS  
UTC Day #070 17:15:36.000  
Sunday, 11 March 2001  
GPS Week = 1105

PC Time  
12:15:36.003  
Eastern Standard Time  
Latency: -1

Sidereal Time  
Local Mean Sidereal Time 23:47:22.86  
Greenwich Mean Sidereal Time 04:33:19.97  
Modified Julian Day 51979.71917

Grid Square  
FN42go.19

TIC (usec)  
-4.0817

GPS Navigation Data

	Latitude	Longitude	Alt(GPS)	Alt(MSL)
Cur:	42° 37.38703'	-71° 29.27853'	130.53m	163.49m
Avg:	42° 37.38703'	-71° 29.27853'	130.53m	163.49m
Ref:	42° 37.38704'	-71° 29.27854'	130.53m	163.49m

Satellites

PRN	EI	Azm	Eb/No	5	15	25	35
8	34 ↓	204	0	Code Search			
31	12 ↓	75	26	AS			
7	43 ↑	276	22	AS			
11	51 ↓	61	33	AS			
2	64 ↑	303	28	AS			
4	4 ↑	211	0	Code Search			
27	14 ↓	185	0	Code Search			
20	19 ↑	128	17	AS			

8 Visible 5 Tracked

Acquiring Satellites or Position Hold

Position Hold Motorola VP, Bin, 8 ch, V10.0, has DGPS, T-RAIM

# TAC32Plus: DISPLAYS Local Station Sidereal Time (LMST)

**Tac32Plus** File Edit View Data Display Help

02:00:03.60

UTC Time from GPS  
 UTC Day #070 19:27:55.000  
 Sunday, 11 March 2001  
 GPS Week = 1105

PC Time  
 14:27:54.998  
 Eastern Standard Time  
 Latency: -1

Sidereal Time  
 Local Mean Sidereal Time 02:00:03.60  
 Greenwich Mean Sidereal Time 06:46:00.71  
 Modified Julian Day 51979.81105

Grid Square FN42go.19  
 TIC (usec) -4.0257

GPS Navigation Data

	Latitude	Longitude	Alt(GPS)	Alt(MSL)
Cur:	42° 37.38703'	-71° 29.27853'	130.53m	163.49m
Avg:	42° 37.38703'	-71° 29.27853'	130.53m	163.49m
Ref:	42° 37.38704'	-71° 29.27854'	130.53m	163.49m

Satellites

PRN	EI	Azim	Eb/No	Eb/No			
				5	15	25	35
7	76 ↓	48	34	AS			
4	60 ↑	248	27	AS			
2	44 ↓	179	23	AS			
20	38 ↓	61	31	AS			
24	21 ↑	239	0	Code Search			
9	15 ↓	286	0	Code Search			
5	5 ↑	321	0	Message Sync Detect			
11	1 ↓	60	17	AS			
1	↑	99	0	Not Locked			

9 Visible 6 Tracked  
 Acquiring Satellites or Position Hold

For Help, press F1 Position Hold Motorola VP, Bin, 8 ch, V10.0, has DGPS, T-RAIM

# TAC32Plus: DISPLAYING TIME-INTERVAL COUNTER READINGS WITH CORRECTIONS

**Tac32Plus**

File Edit View Data Display Help

**-4.0417**

UTC Time from GPS  
UTC Day #070 17:24:12.000  
Sunday, 11 March 2001  
GPS Week = 1105

PC Time  
12:24:11.996  
Eastern Standard Time  
Latency: -1

Sidereal Time  
Local Mean Sidereal Time 23:56:00.27  
Greenwich Mean Sidereal Time 04:41:57.39  
Modified Julian Day 51979.72514

Grid Square  
FN42go.19

TIC (usec)  
-4.0417

GPS Navigation Data

	Latitude	Longitude	Alt(GPS)	Alt(MSL)
Cur:	42° 37.38703'	-71° 29.27853'	130.53m	163.49m
Avg:	42° 37.38703'	-71° 29.27853'	130.53m	163.49m
Ref:	42° 37.38704'	-71° 29.27854'	130.53m	163.49m

Satellites

PRN	EI	Azm	Eb/No	Eb/No			
				5	15	25	35
8	30 ↓	202	19	AS			
31	9 ↓	77	25	AS			
7	46 ↑	279	21	AS			
11	48 ↓	58	34	AS			
2	68 ↑	300	27	AS			
4	7 ↑	212	0	Code Search			
27	10 ↓	184	22	AS			
20	22 ↑	125	23	AS			
9	↑	331	0	Not Locked			

9 Visible 7 Tracked

Acquiring Satellites or Position Hold

For Help, press F1

Position Hold

Motorola VP, Bin, 8 ch, V10.0, has DGPS, T-RAIM

Recycle Bin

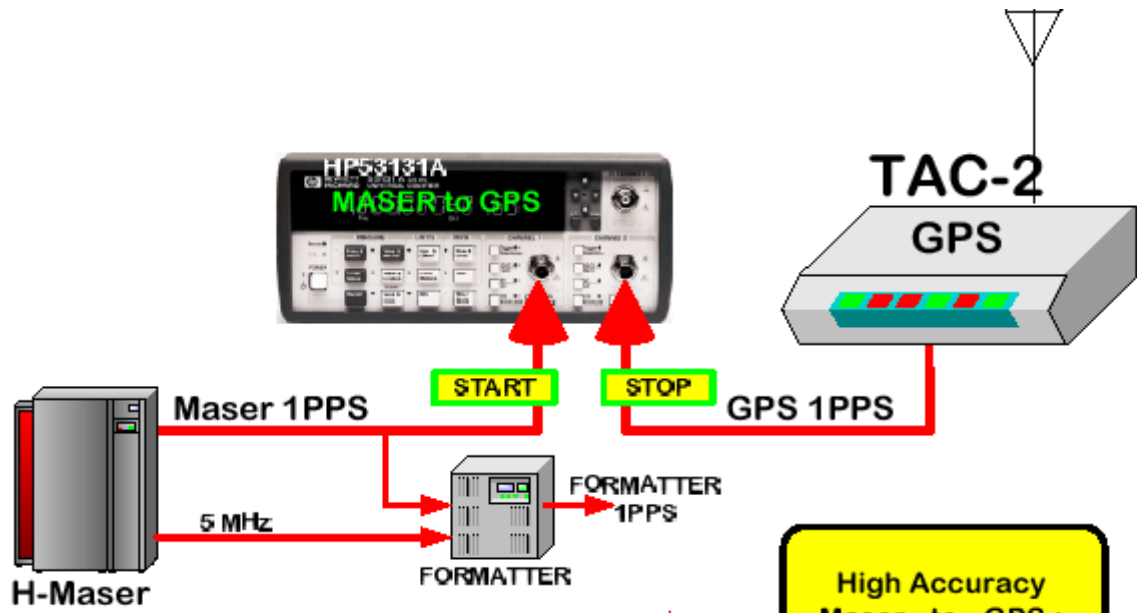

If the Maser 1PPS Tick occurs BEFORE the UTC Second.

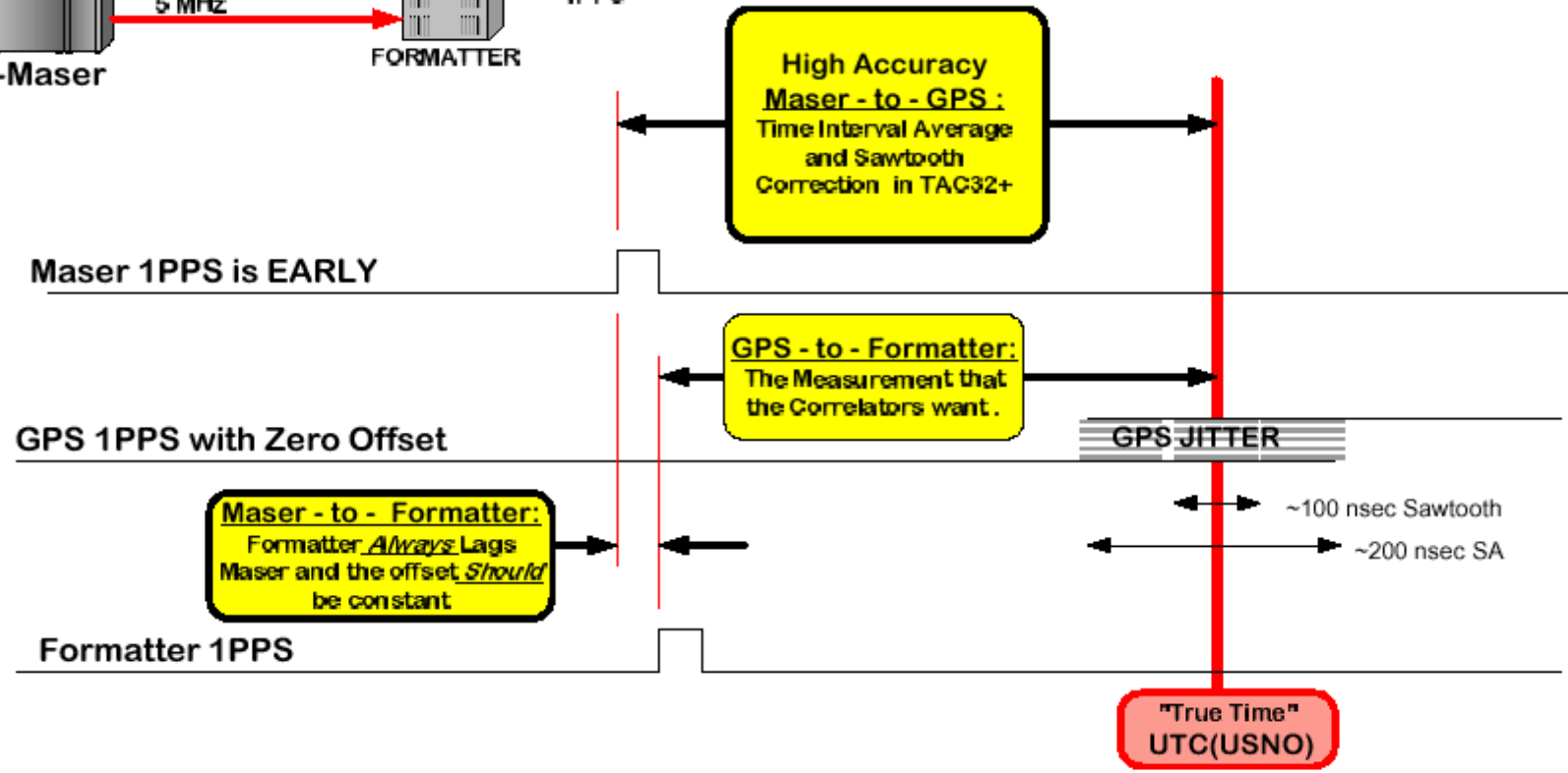

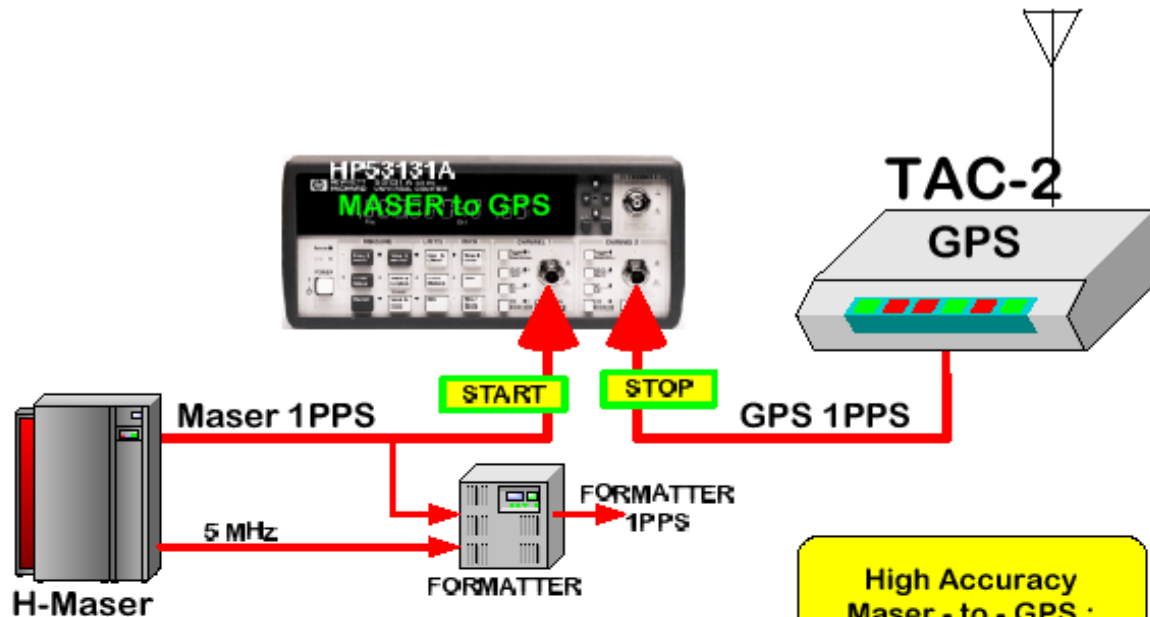

If the Maser 1PPS Tick occurs AFTER the UTC Second.

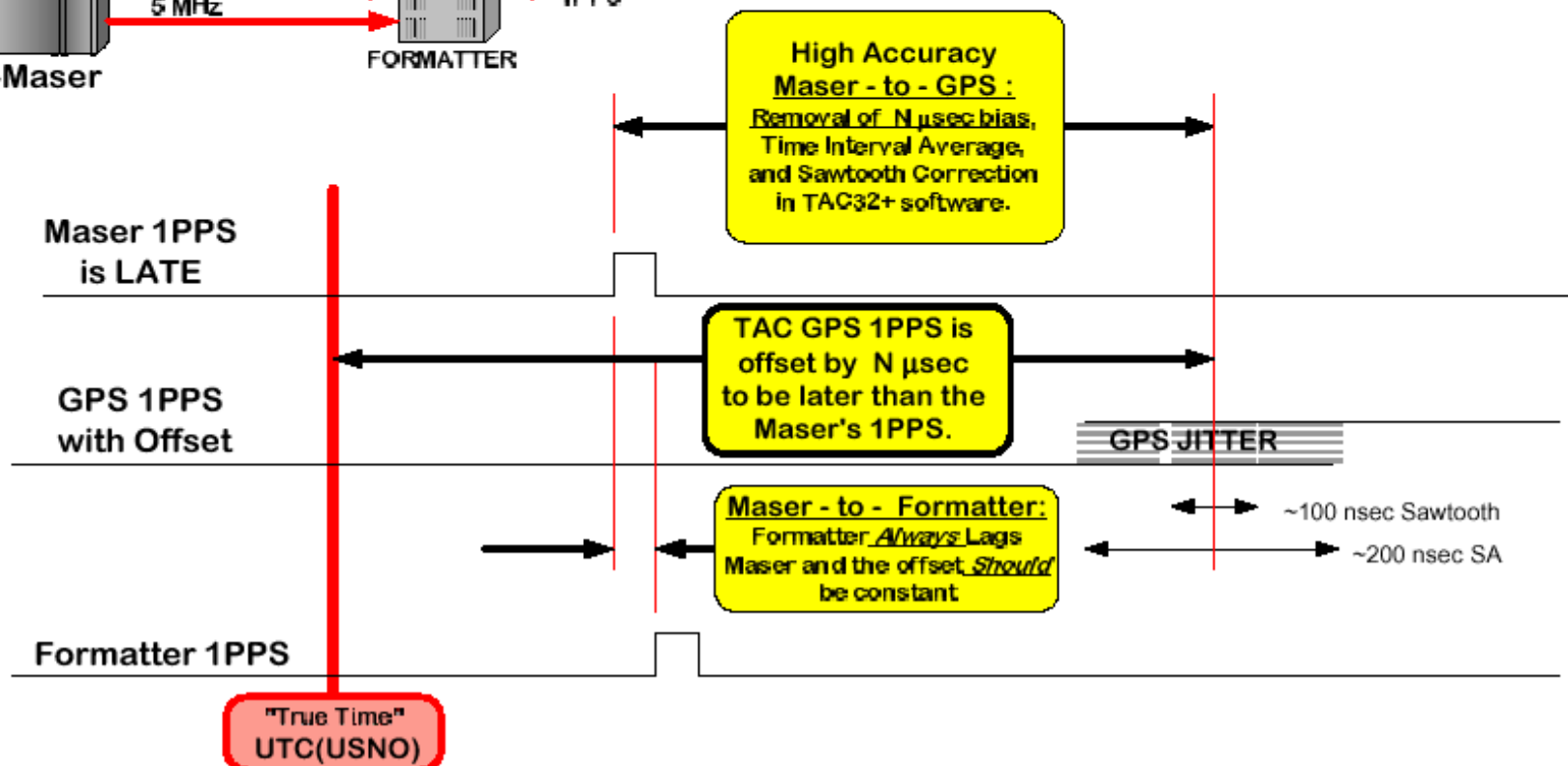

# To Make Sure TAC32 is Logging the “true” Maser-to-GPS Time Interval:

Offset GPS LATE if needed to be certain that GPS 1PPS is later than Maser 1PPS.

Be certain to account for the lengths of all coax cables.

Allow the software to correct for all timing offsets.

Allow software to correct the 1PPS pulse-to-pulse jitter

The screenshot shows the Tac32Plus Timing Setup dialog box. The following settings are circled in red:

- Epoch (Coarse): 10 milliseconds
- Offset (Fine): 10 microseconds
- Antenna Cable Delay: 30.3 nanoseconds
- Measurement Cable Delay: 0 nanoseconds
- Internal Receiver Delay: 8 nanoseconds
- Intentional Extra Early Offset: 0 microseconds
- Total 1 PPS offset from UTC: -999990 = 10 microseconds
- Auto correct TIC data:
- Sawtooth Correction:  Automatic

The dialog box also includes sections for Epoch Offset (GPS 1PPS Pulses LATE), Instrumentation Offset (GPS 1PPS Pulses EARLY), T-RAIM (Limit: 500 nanoseconds, Kill 1pps on fail), and UTC Correction (38 nanoseconds). The background shows the Tac32Plus main window with a large digital display showing '18:1' and various time-related data.

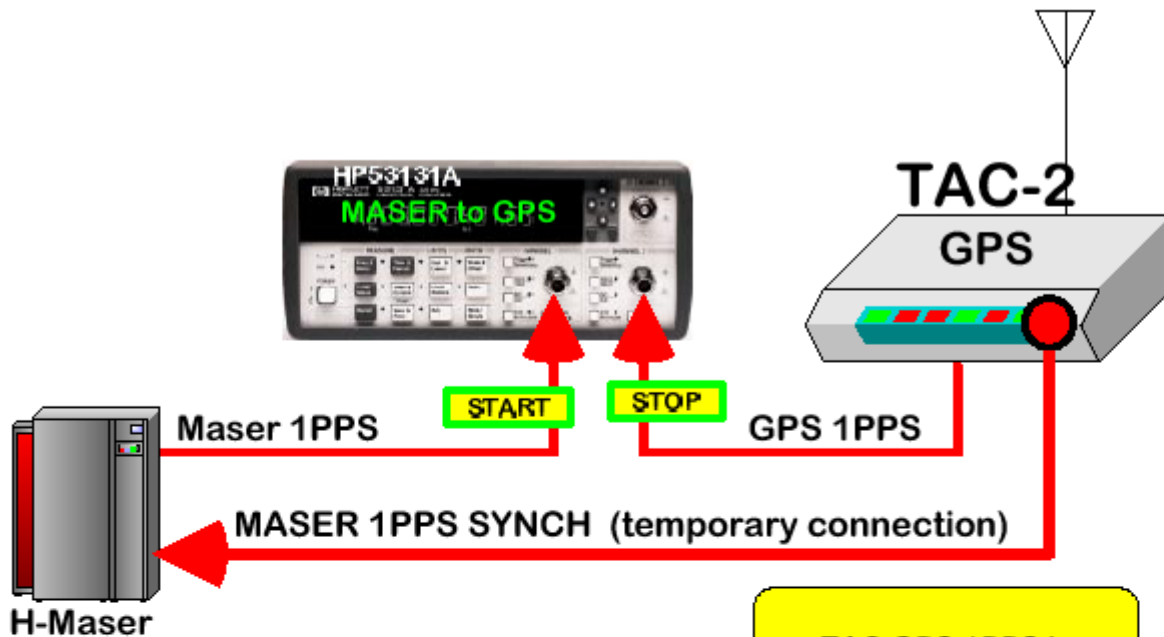

**SPECIAL CASE:**  
If you need to use the TAC to re-synchronize the Maser's 1PPS Signal.

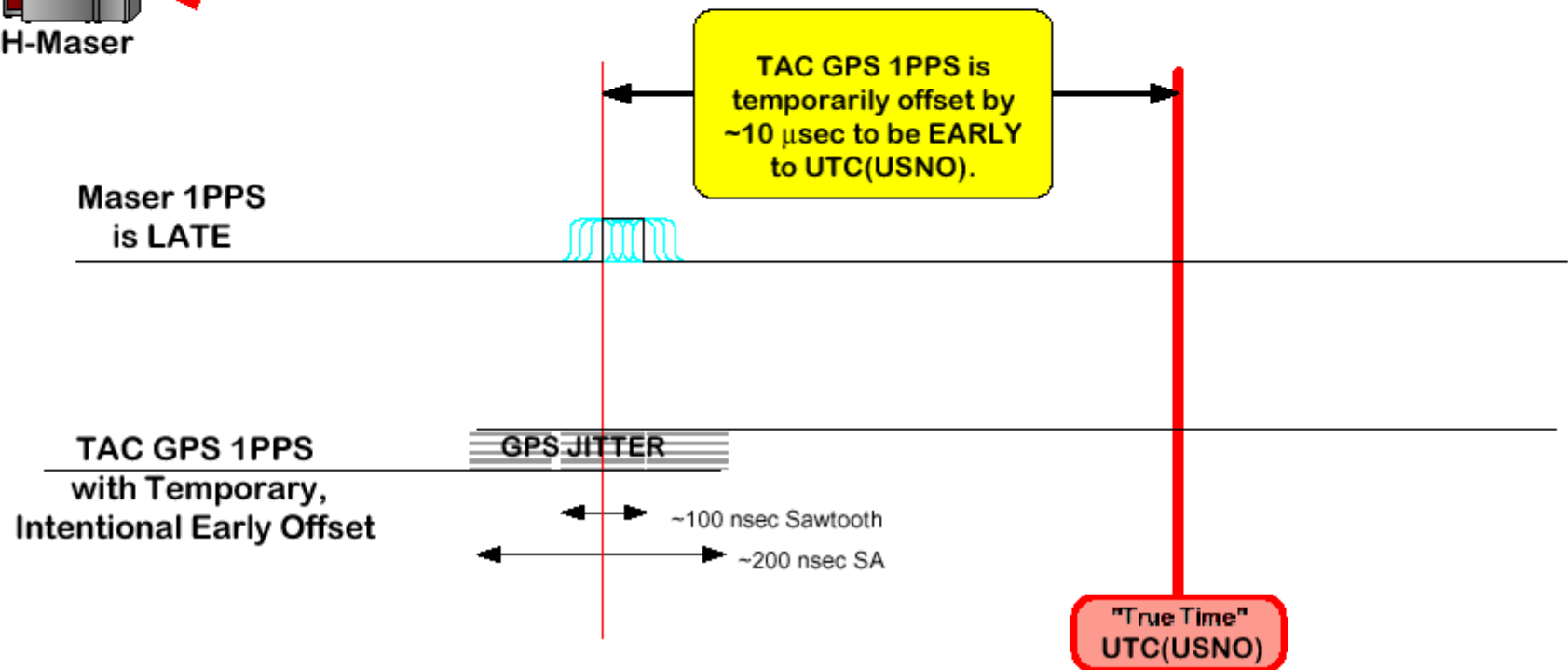



# To Activate the LAN Telnet Link between TAC32Plus and the LINUX PC Field System, Hit Control-T:

Then Click on the check-box and the OK button

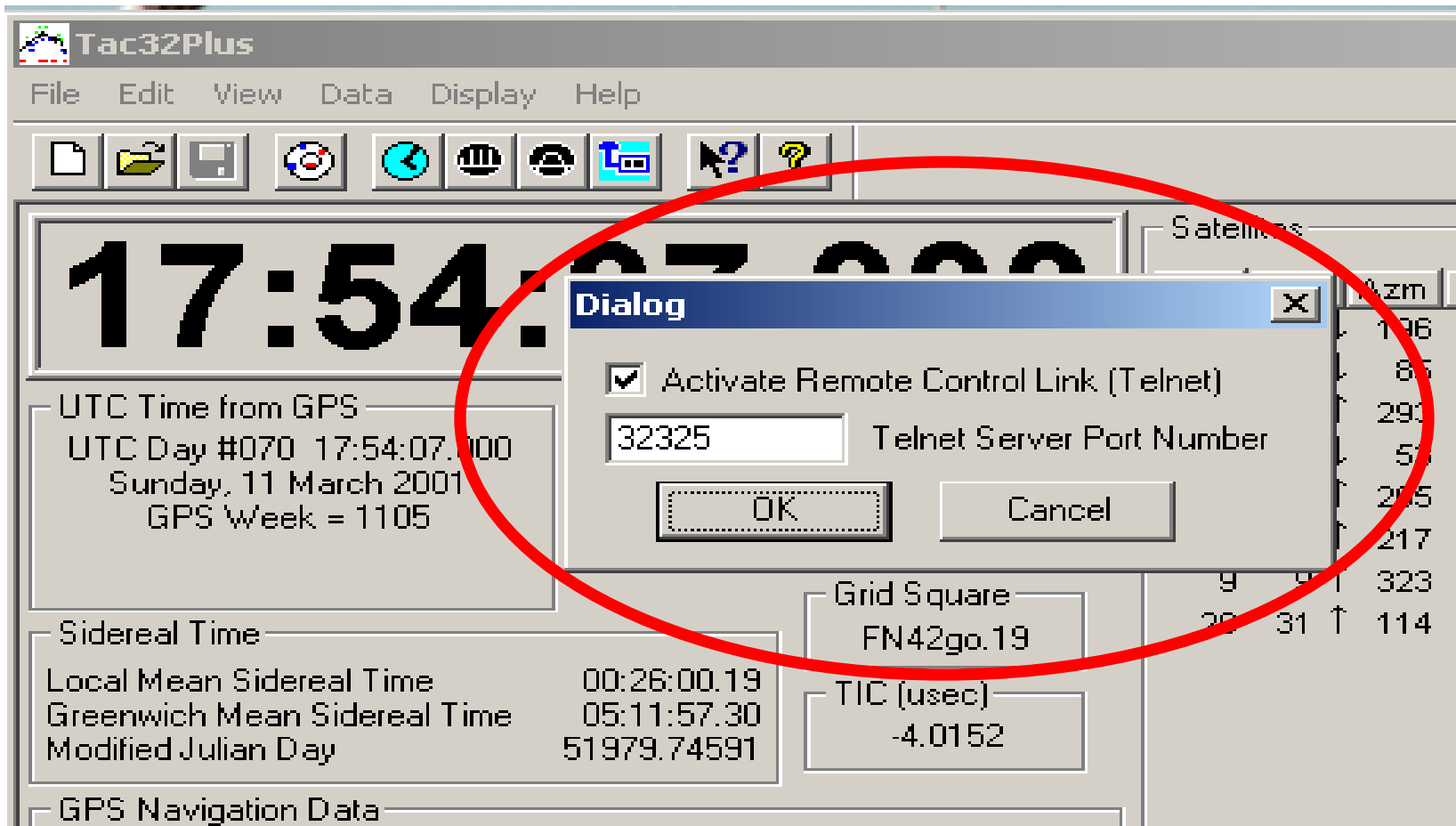

# To Use TAC32Plus as your Station's SNTP Network Timer Server:

The screenshot shows the Tac32Plus software interface. The 'Data' menu is open, and the 'Network Time Server' option is selected, which has opened a sub-menu. In this sub-menu, the 'SNTP Server (RFC 2030)' option is highlighted with a blue background and a checkmark, indicating it is the active selection. A red oval is drawn around the 'Network Time Server' menu and its sub-menu options.

**Network Time Server Sub-menu:**

- Disable
- SNTP Server (RFC 2030)
- UDP/IP Server (RFC 868)

**Other visible interface elements:**

- Large digital display showing '18:00'.
- UTC Time from GPS: Sunday, 11 M, GPS Week.
- Sidereal Time: Local Mean Sidereal Time 00:44:11.17, Greenwich Mean Sidereal Time 05:30:08.28, Modified Julian Day 51979.75851.
- GPS Navigation Data table:

	Latitude	Longitude	Alt(GPS)	Alt(MSL)
Cur:	42° 37.38703'	-71° 29.27853'	130.53m	163.49m
Avg:	42° 37.38703'	-71° 29.27853'	130.53m	163.49m
Ref:	42° 37.38704'	-71° 29.27854'	130.53m	163.49m

Bottom status bar: Activate SNTP Time Server, Position Hold, Motorola VP, Bin, 8

# APPENDIX B TEXT MATERIAL

-- Field System Documentation for tacd

-- Ed Himwich's documentation for gpsoff

-- David Holland's HP53131 setup notes