

# High-accuracy Time and Frequency in VLBI

Katie Pazamickas  
kpazamic@peraton.com



Richard Hambly  
Rick@cnsys.com



# Agenda

## Background – Richard Hambly

- Oscillators and Clocks
- What “Clock” Performance Does VLBI Need?
- “Absolute Time” (i.e., Clock Accuracy )

## The Hydrogen Maser - Katie Pazamickas

- Maser Outputs
- Data/Frequency Monitoring
- Troubleshooting/Routine Maintenance

## GPS Time - Richard Hambly

- More on Troubleshooting and Performance monitoring
- Week rollover may mean retiring old GPS receivers
- GPS receiver quantization error
- “Absolute” Receiver Calibration
- New developments

# The Difference Between Frequency and Time Oscillators and Clocks



## Oscillator

- Escapement Wheels & Pendulums
- Crystal Oscillators
- Cavity Oscillators
- Oscillator Locked to Atomic Transition
  - Rubidium (6.8 GHz)
  - Cesium (9.1 GHz)
  - Hydrogen Maser (1.4 GHz)

Events that occur with a  
defined

**FREQUENCY**

nsec -- minutes

## Integrator and Display = Clock

- Gears
- Electronic Counters
- Real Clocks

Long-Term

**TIMING**

seconds - years

# Allan Variance – A graphical look at clock performance

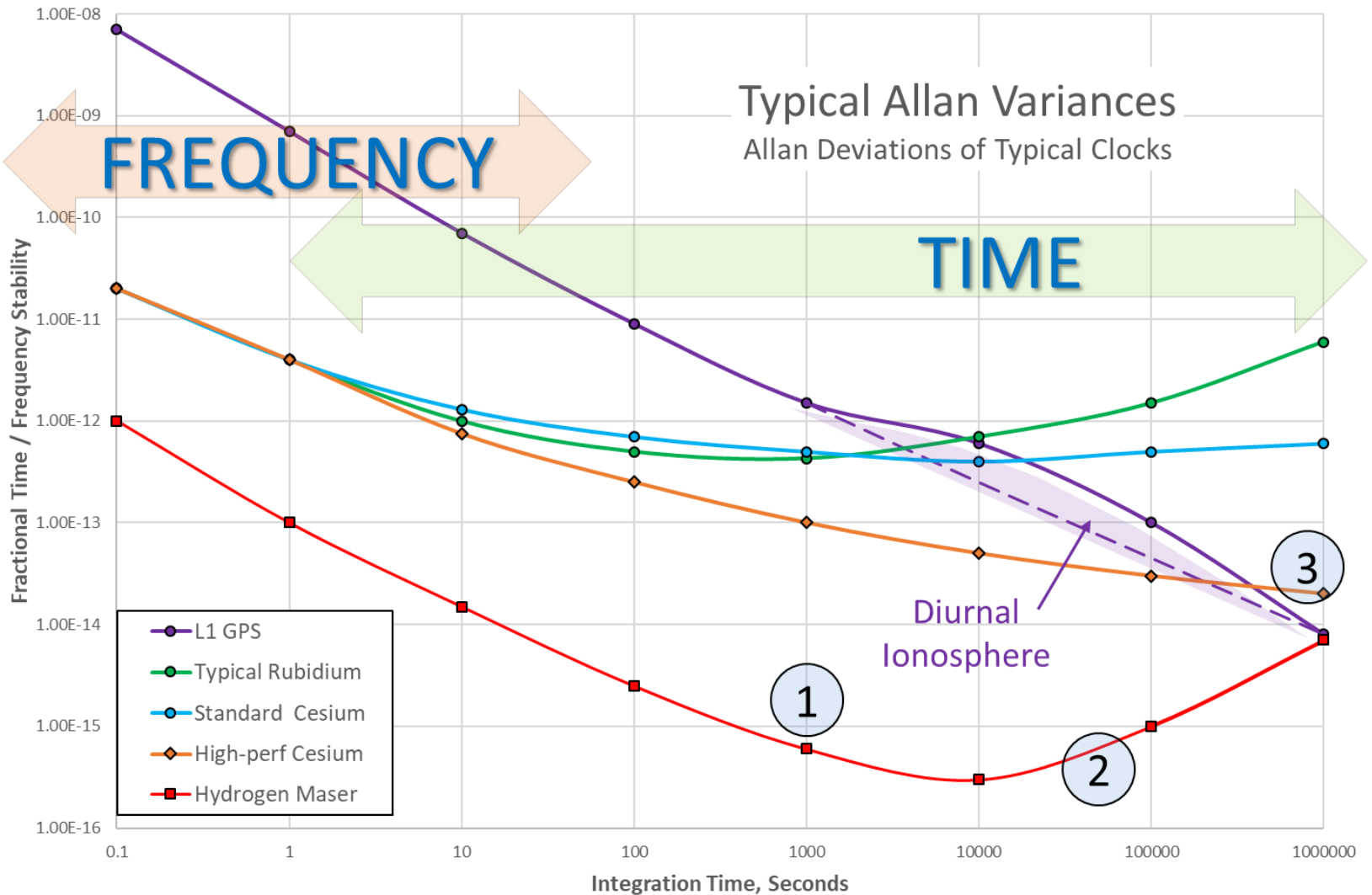

# What “Clock” Performance Does VLBI Need?

The Radio Astronomy and Geodesy VLBI community uses Hydrogen Masers at about 50 remote sites around the world.

To achieve  $\sim 10^\circ$  signal coherence for  $\sim 1000$  seconds at 10 GHz we need the two clocks (oscillators) at the ends of the interferometer to maintain relative stability of:

- $\approx [ 10^\circ / (360^\circ * 10^{10} \text{ Hz} * 10^3 \text{ sec}) ]$
- $\approx 2.8 * 10^{-15} @ 1000 \text{ sec.}$

1

# What “Clock” Performance Does VLBI Need?

In Geodetic applications, the station clocks are modeled at relative levels  $\sim 30$  psec over a day:

- $\approx [30 * 10^{-12} / 86400 \text{ sec}]$   
 $\approx 3.5 * 10^{-16} @ 1 \text{ day}$

2

- A hydrogen maser provides this level of performance.



# What “Clock” Performance Does VLBI Need?

To correlate data acquired at 16 Mb/s, station timing at relative levels  $\sim 50$  nsec or better is needed.

After a few days of inactivity, this requires:

- $\approx [50 * 10^{-9} / 10^6 \text{ sec}]$
- H-maser  $\rightarrow \approx 5 * 10^{-14} @ 10^6 \text{ sec}$



---

Since VLBI now defines UT1, VLBI needs to control  $[\text{UTC}_{(\text{USNO})} - \text{UTC}_{(\text{VLBI})}]$  with an **ACCURACY** (traceable to USNO)

- $\approx 100$  nsec to  $1 \mu\text{sec}$

---

To detect problems, VLBI should monitor the long-term behavior of the Hydrogen Masers (at least) every hour with

**PRECISION**

- $\approx 10$  to  $50$  nsec

# Allan Deviation – A graphical look at clock performance

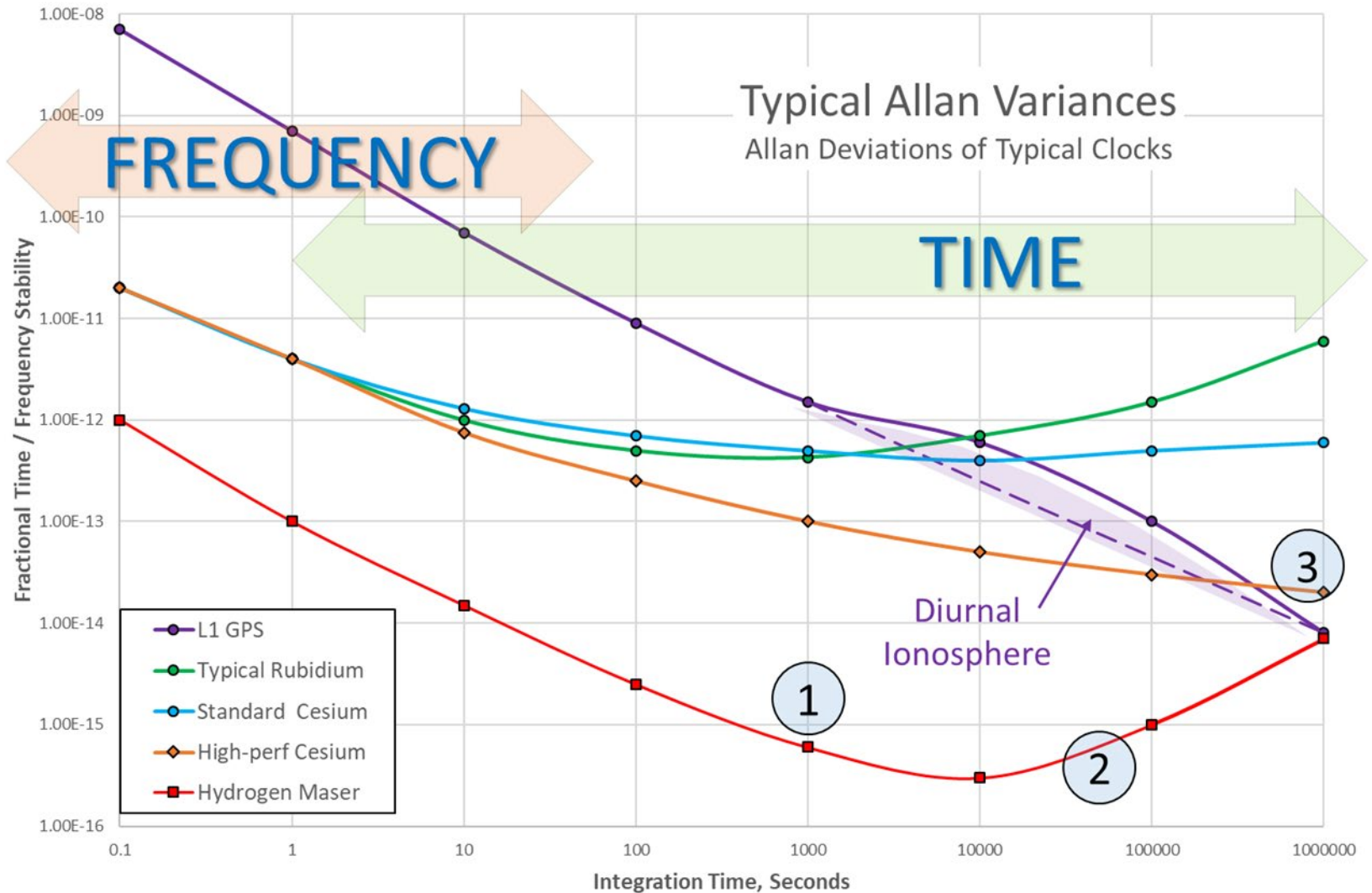



# Why do we need to worry about “Absolute Time” (i.e., Clock Accuracy) in VLBI?

The only real reason for worrying about “absolute time” is to relate the position of the earth to the position of the stars:

- Generating Sidereal Time to point antennas.
- Measuring UT1 (i.e., “Sundial Time”) to see changes due to redistribution of mass in/on the earth over long periods of time (a.k.a. “The Reference Frame”)
- Knowing the position of the earth with respect to the moon, planets and satellites.
- Making the correlation and data analysis jobs easier

# Why do we need to worry about “Absolute Time” (i.e., Clock Accuracy) in VLBI?

At the stations this means that we will need to pay attention to timing elements like

- Frequency Standard and Station Timing
- The lengths of all signal & clock cables
- The geometry of the feed/receiver to the antenna.
- Calibration of instrumental delays inside the receiver and backend.
- The care with which system changes are reported to the correlators and the data analysts.

# VLBI's "REAL" Clocks (#1)

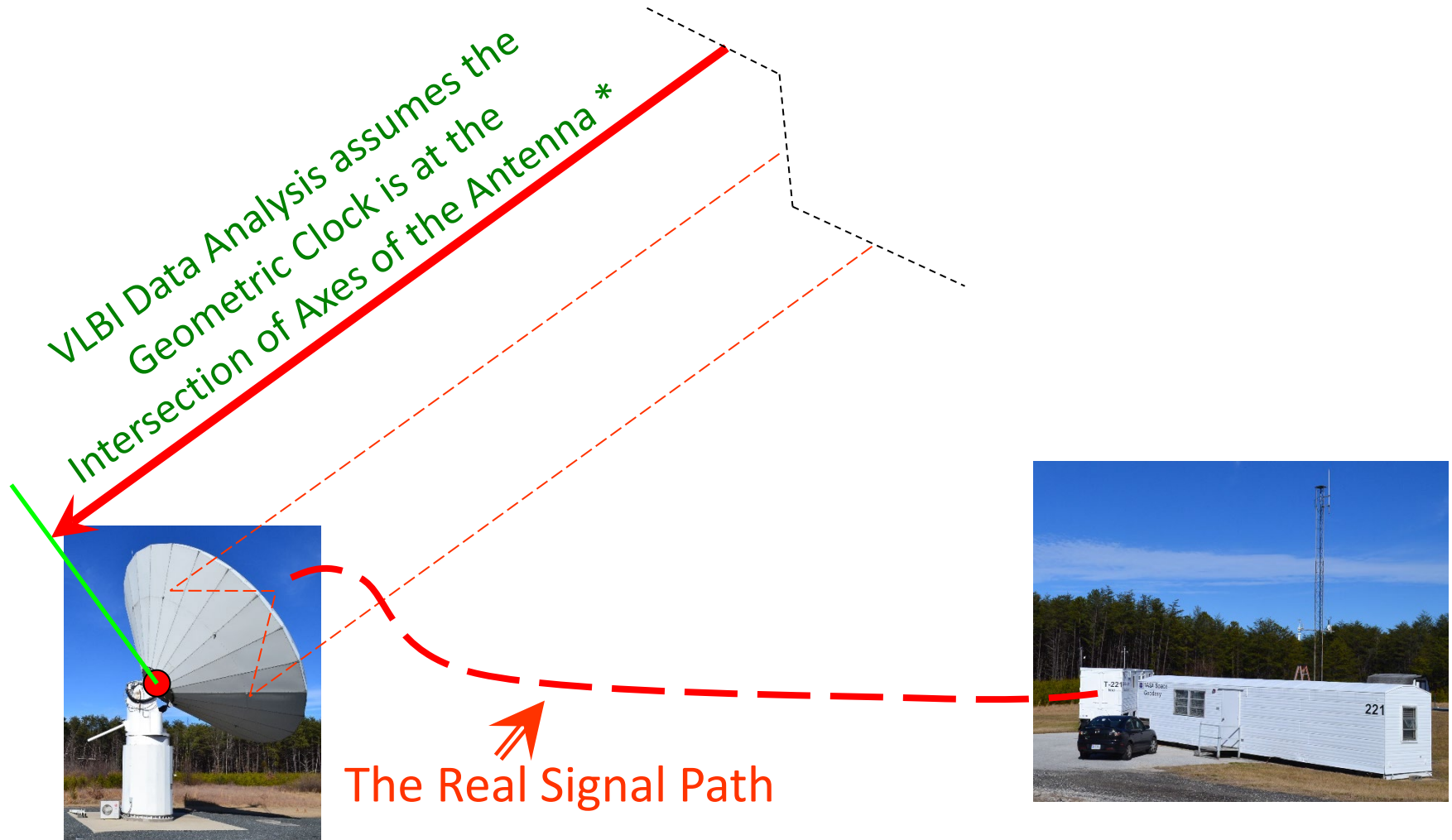

\* Note -- If the axes don't intersect, then an "offset axis" model of the antenna is used

# VLBI's "REAL" Clocks (#2)

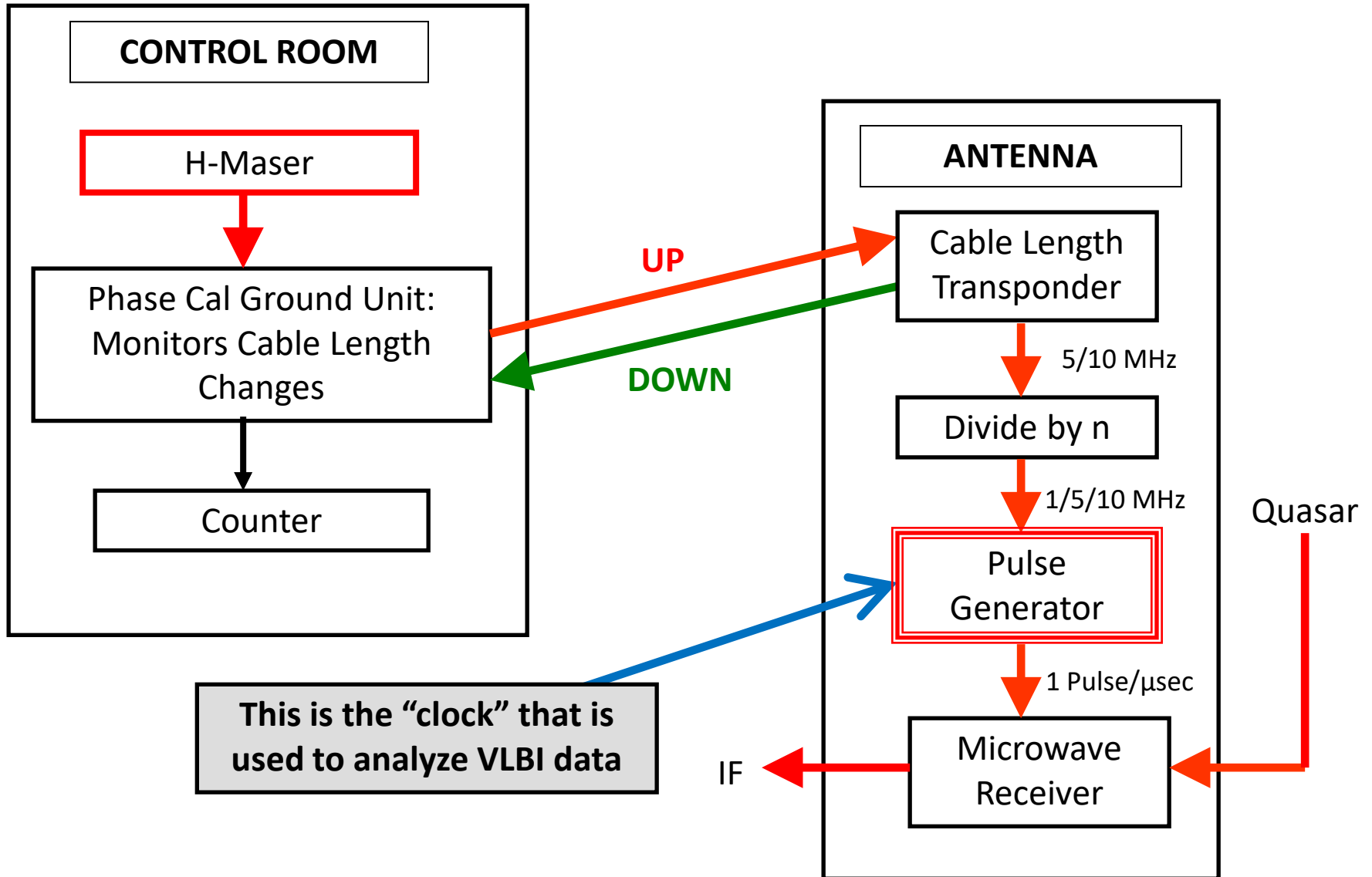

# VLBI's "REAL" Clocks (#3)

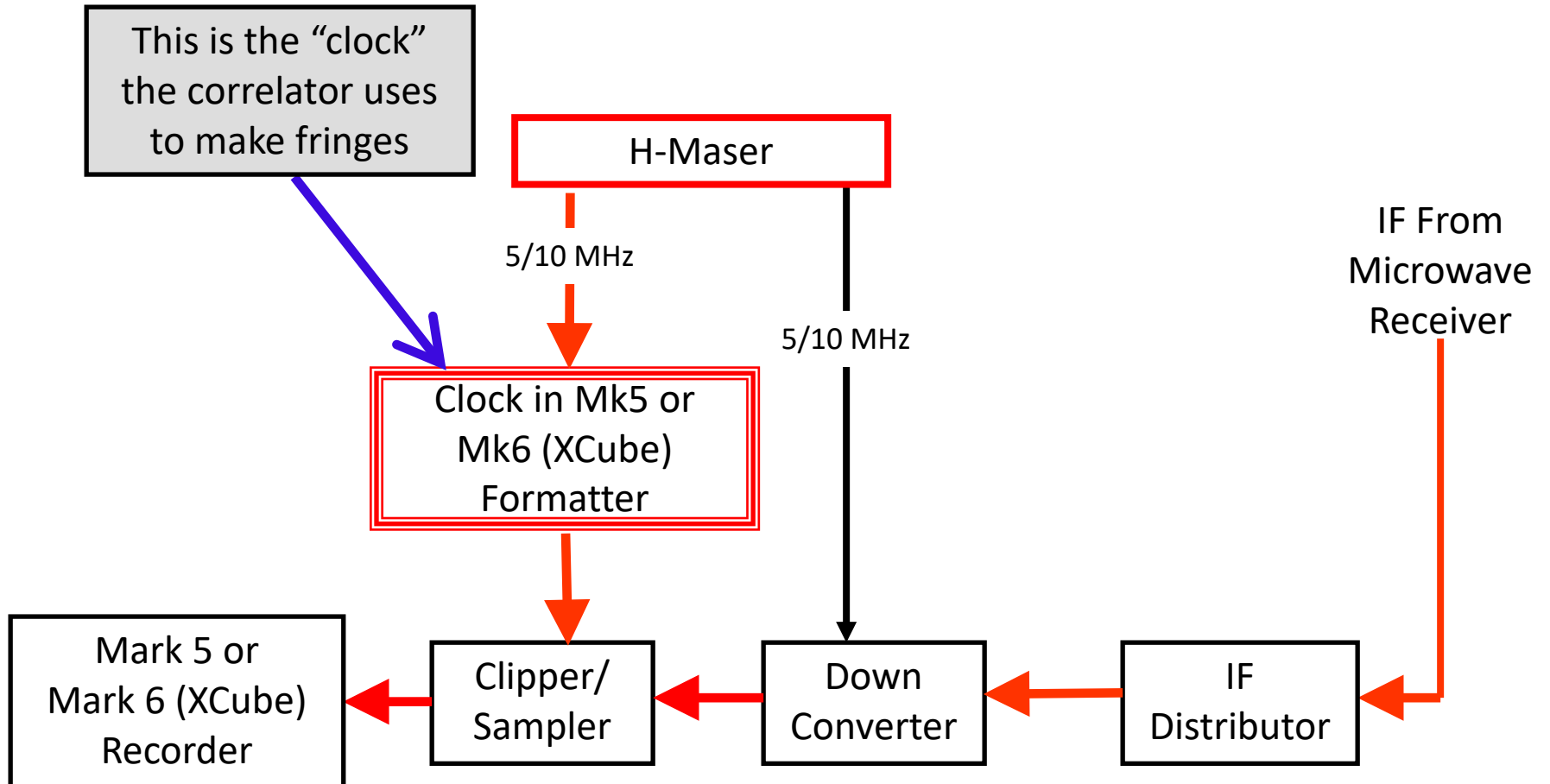

# Setting VLBI Clock Time & Rate with GPS

- ⊗ **Compare two distant clocks by observing the same GPS satellite(s) at the same time** (also called **Common View**)
  - Requires some inter-visibility between sites
  - Requires some near-real-time communication
  - Links you directly to the “Master Clock” on the other end at  $\sim 1$  nsec level
- ⊗ **Use Geodetic GPS receivers** (i.e., as an extension of the IGS network)
  - Requires high quality receiver but it’s hard to gain access to the internal clock.
  - Requires transferring  $\sim 1$  MB/day of data from site
  - Requires extensive computations using dual-frequency data to get  $\sim 300$  psec results with ionosphere corrections
  - Allows Geodetic community to use VLBI Site (and H-Maser) for geodesy
  - Difficult to obtain “Real Time” clock pulses!



## **Use the Broadcast GPS Timing Signals as a clock**

- Yields “Real Time” 10-30 nsec results with low-cost hardware
- Single Frequency L1 only suffers from ionospheric error but dual frequency receivers are now available.

# How we get less than 5 nsec 1-sigma timing

- Start with a good timing receiver, like the CNS Clock II with the Synergy SSR (u-blox M8) front end.
- Average the positioning data for 1 to 2 days to determine the station's coordinates. This should be good to <5 meters. If the site has been accurately surveyed, use these values.
- Lock the receiver's position to this average.
- Make sure that your Time-Interval Counter (TIC) is triggering cleanly. Start the counter with the 1 PPS signal from the "house" atomic clock and stop with the GPS receiver's 1PPS.
- Average the individual one/second TIC readings over ~5 minutes (300 seconds).
- These steps are semi-automated in Tac32Plus & GPSTime.

# IVS Recommended Maser Timing Practices

- IVS Memorandum 2014-001v01, 29 April 2014

## *IVS Recommended Maser Timing Practices*

Roberto Ambrosini, Tom Clark, Brian Corey, Ed Himwich

<https://ivscc.gsfc.nasa.gov/publications/memos/ivs-2014-001v01.pdf>

- *Tac32Plus, Tac32Multi Time Interval Counter (TIC) Module*

<https://www.cnssys.com/documents/Tac32Plus.pdf>

- When recording data with Tac32Plus or GPSTime, set up as shown here:

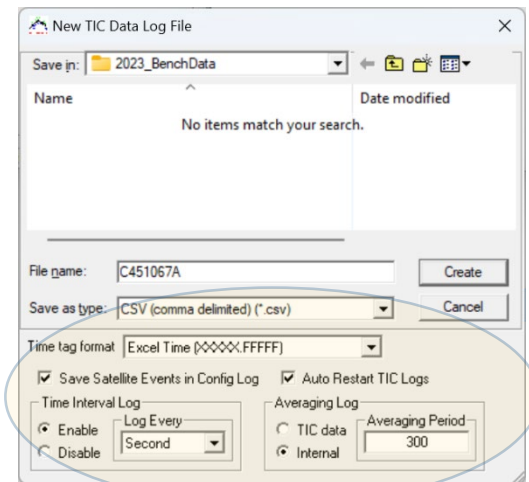



# Hydrogen Masers



# Physics Package

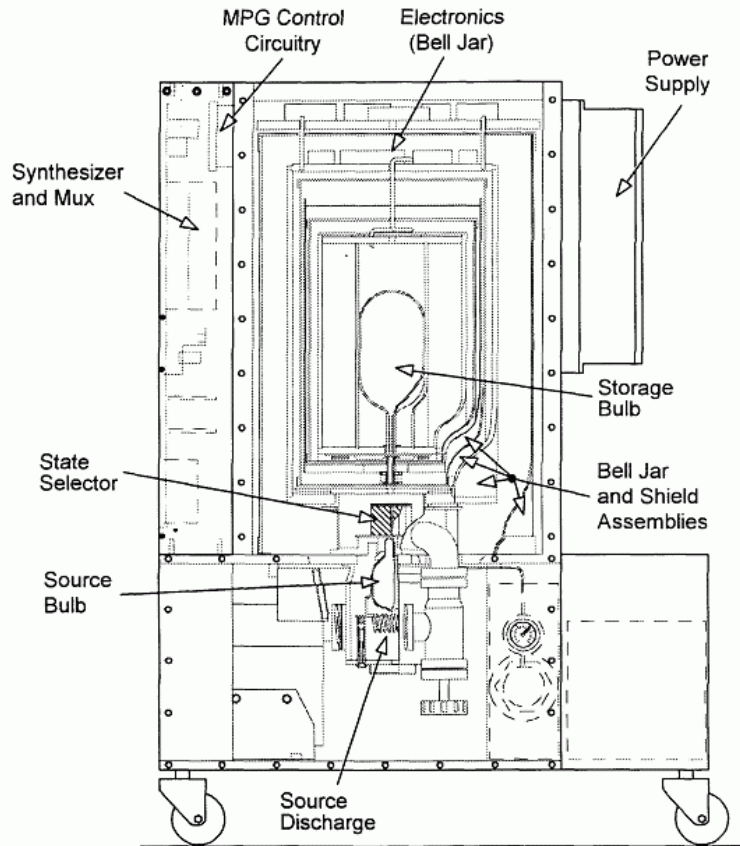

Figure 4. Hydrogen Maser, Physics Layout and Identification.

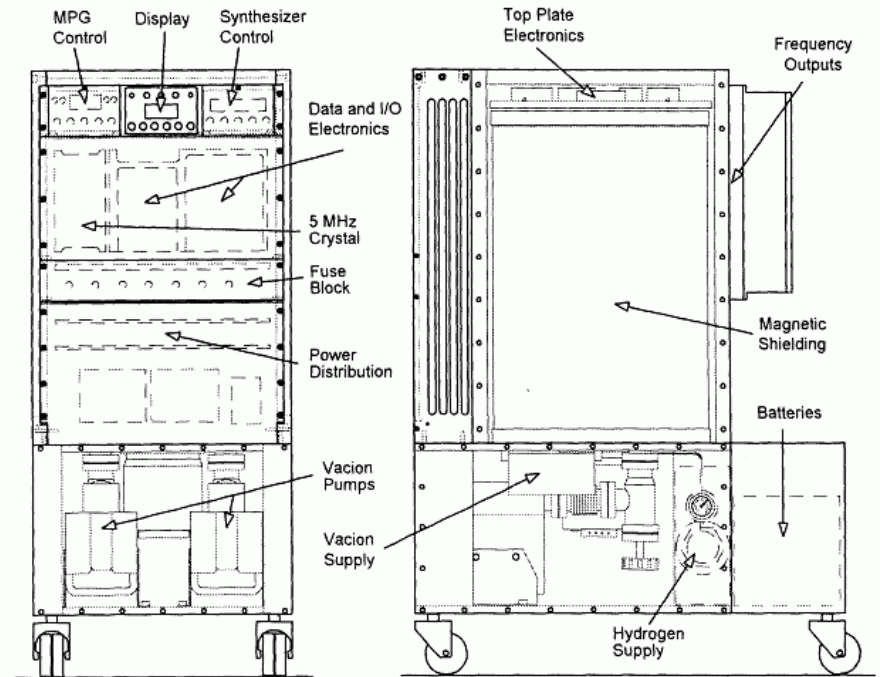

Figure 3. Hydrogen Maser, System Layout and Identification.

Credit: Microsemi MHM2010 Manual

Credit: Microsemi MHM2010 Manual

# Maser Outputs

## Sigma Tau MHM-2010 & MHM-2020

- 2 5MHz
- 2 10 MHz
- 2 1PPS
- Maser Data
- Sync Port
- Data telemetry screen



# Timing Configuration



CNS Clock II

Original CNS Clock

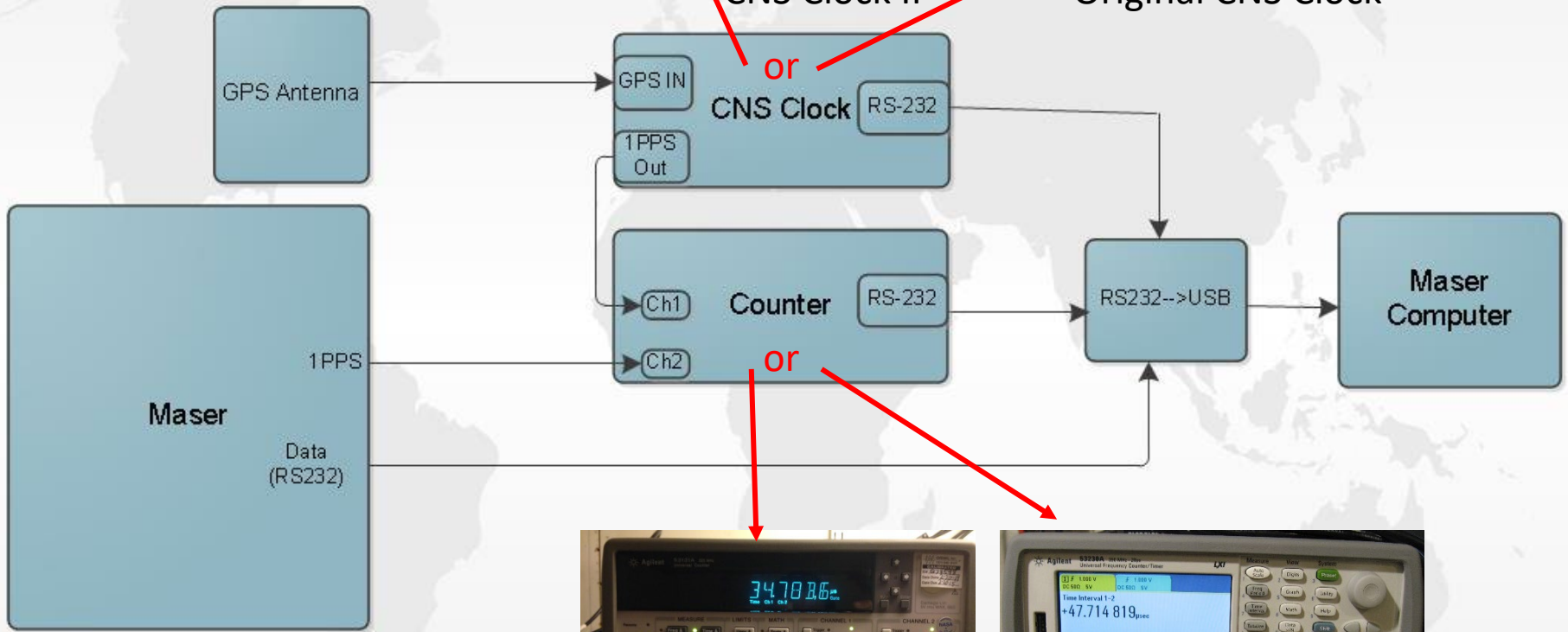

53132A

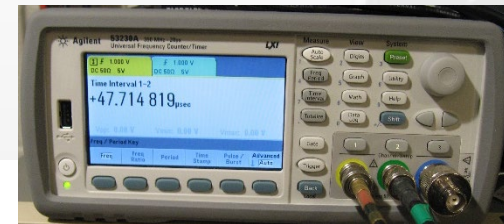

53230A

# Data/Frequency Monitoring

## Maser Data Monitoring

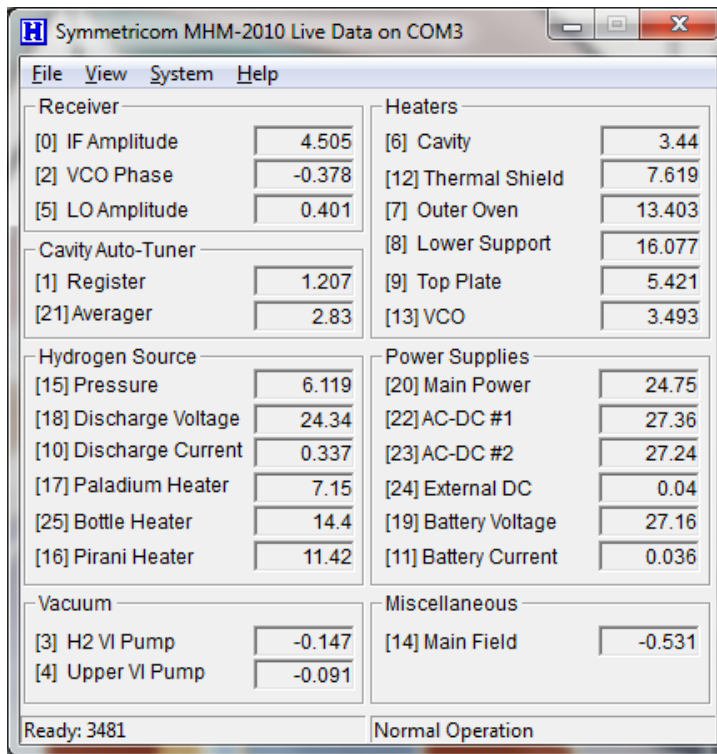

## Frequency Data – Tac32Plus

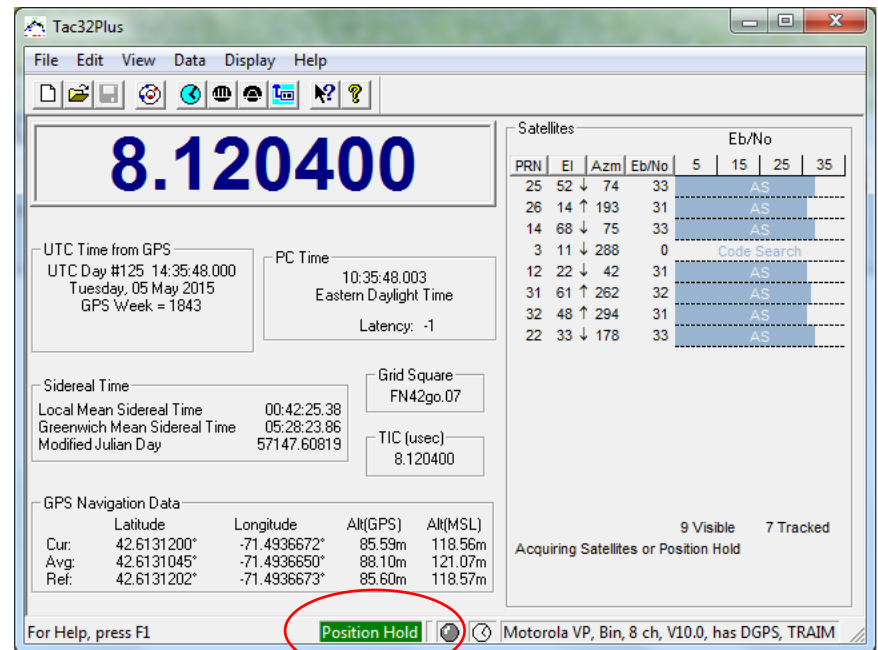

# Data/Frequency Monitoring

This data set shows the H-maser frequency error of about  $7 \cdot 10^{-14}$

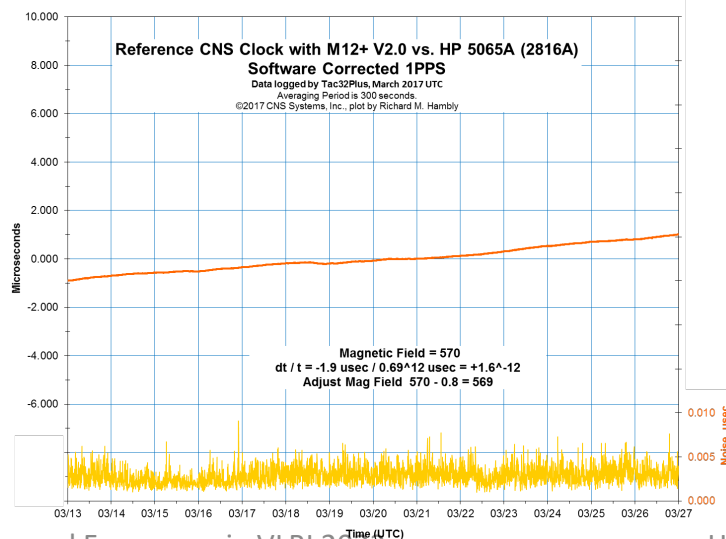
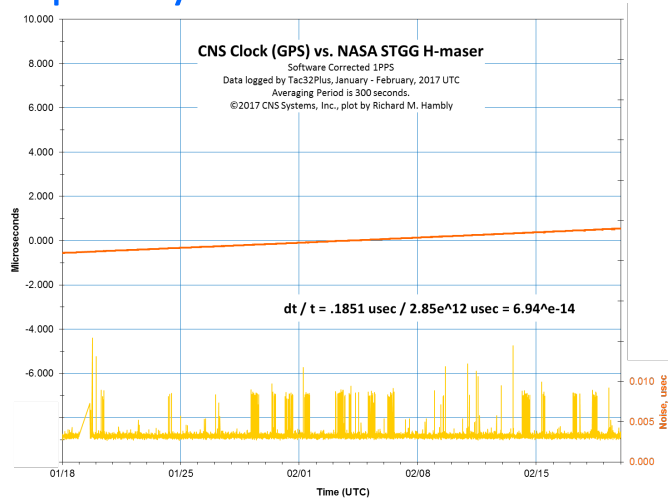

Time and Frequency in VLBI 2023

H-Maser

A more detailed look at the data set shows an old GPS receiver with known data issues. This GPS receiver should be upgraded or replaced.

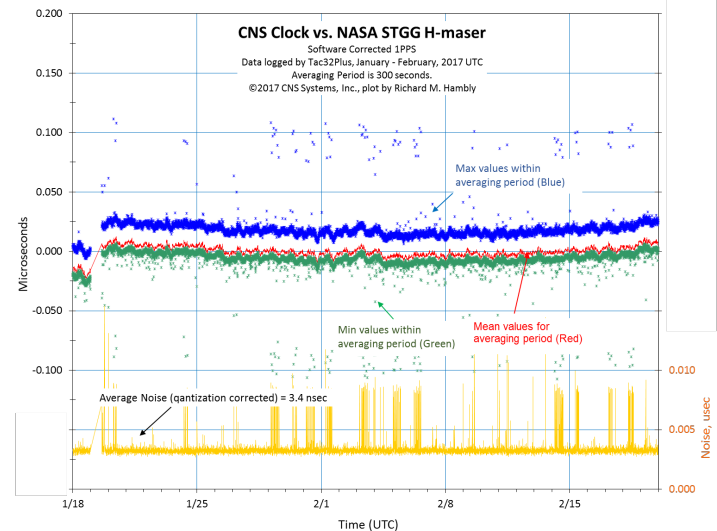

For comparison, this data set shows the CNS HP5065 Rubidium frequency error of about  $1.6 \cdot 10^{-12}$

# Troubleshooting/Routine Maintenance

- Power Outages
  - Temperature instabilities-heater currents
  - Loss of IF/VCO
  - Backup Batteries
- Adjust VCO
- Adjust Cavity Register
- Hydrogen tank supplied for 20 years of operation
- Vacuum pumps are designed for over 20 years of operation before needing maintenance
- Frequency corrections are not needed because the auto-tuner is continuously on

# More on Troubleshooting and Performance Monitoring

- NTP Time Performance.
- Westford Time or Frequency Problem?
- Need to replace old GPS receiver modules.





# Westford Time or Frequency Problem?

First, we will look at good data for reference.

Then we will look at recent data from Westford and try to determine what is wrong, if anything.

The following slides are the output from a new data analysis tool written in Python that automatically gathers up data from many Tac32Plus TIC “A” and “T” log files that may be on any network accessible computer and produces a single multi-page PDF report file for analysis.

# GNSS Test Bed Analysis



## User Input

Data Directory containing the Tac32Plus or GPSTime data files

Output Directory for the report file

Enter the start time for the Average Data charts

Enter the duration (days) for the Average Data charts.

Enter the Average Data sample size

 <- This is needed to validate each data line

Enter the Time (noise) data start time.

 <- Note that the one hour block of data must be in a single data file

Enter the Magnetic Field Setting (optional).

 <- This is for an HP5064A Rubidium Standard. If not needed, set blank or zero.

### Data sets to include in the report

Enter the Prefix for the data file series	Enter the Primary Header	Enter the Secondary Header Extension
<input checked="" type="checkbox"/> CNSA	CNS Clock "A" (M12+) vs. HP5065A (2816A)	Software corrected 1PPS with 8 nsec RxDelay.
<input checked="" type="checkbox"/> C449	CNS Clock II 404449 (SSR-M8F+) vs. HP5065A (2816A)	Hardware corrected PPS with 48 nsec RxDelay.
<input checked="" type="checkbox"/> C450	CNS Clock II 404450 (SSR-M8F+) vs. HP5065A (2816A)	Hardware corrected PPS with 48 nsec RxDelay.
<input checked="" type="checkbox"/> C451	CNS Clock II 404451 (SSR-M8F+) vs. HP5065A (2816A)	Hardware corrected PPS with 48 nsec RxDelay.

# CNS Clock "A" (M12+) vs. HP5065A (2816A) Drift Chart

Data logged by Tac32Plus. Analyzed by Python + Pandas on 01-Mar-2023, © 2023 CNS Systems, Inc.  
Averaging period is 300 seconds, Software corrected 1PPS with 8 nsec RxDelay.

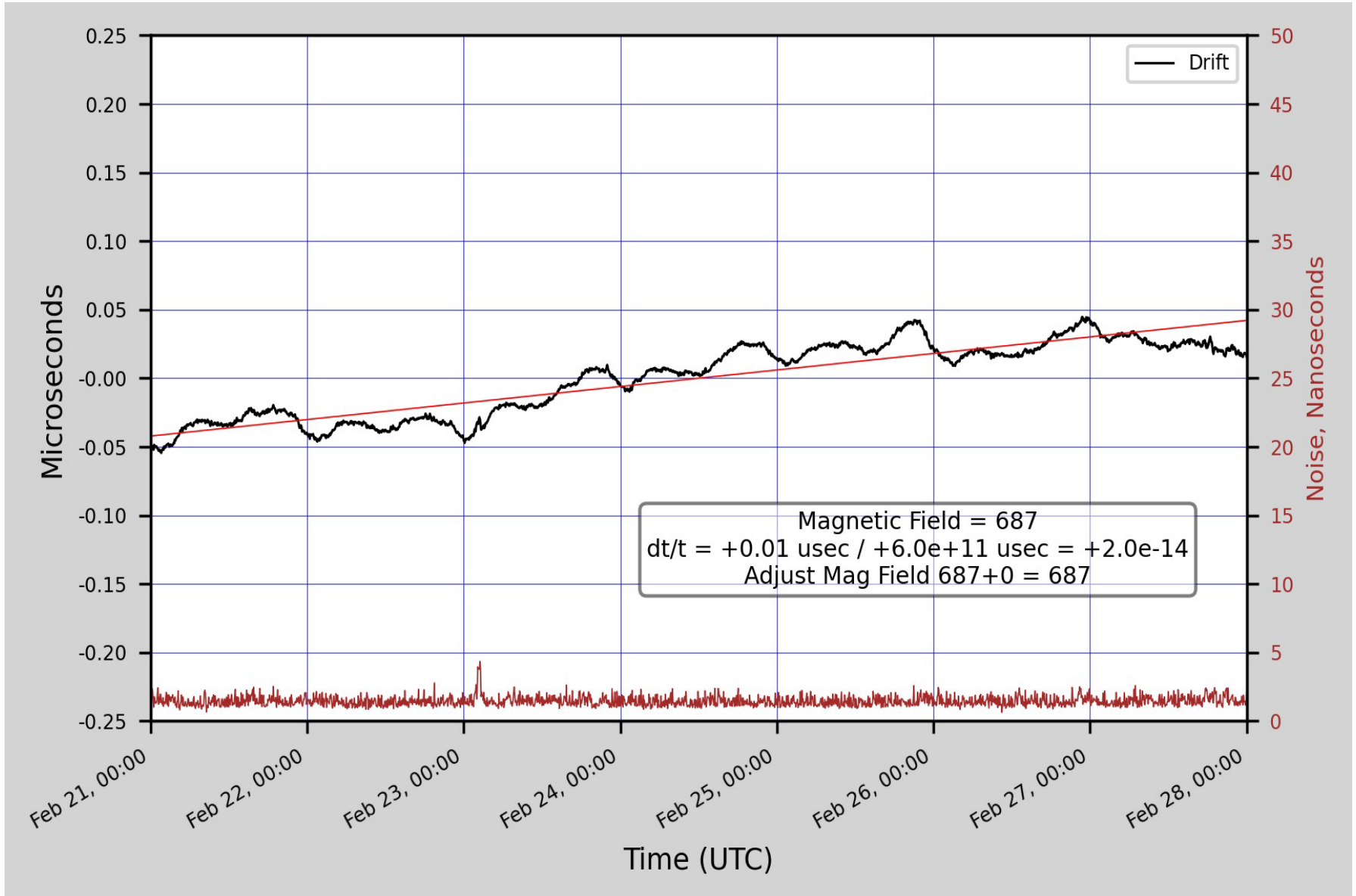

# CNS Clock "A" (M12+) vs. HP5065A (2816A) Average Data Chart

Data logged by Tac32Plus. Analyzed by Python + Pandas on 01-Mar-2023, © 2023 CNS Systems, Inc.  
Averaging period is 300 seconds, Osc drift removed, Software corrected 1PPS with 8 nsec RxDelay.

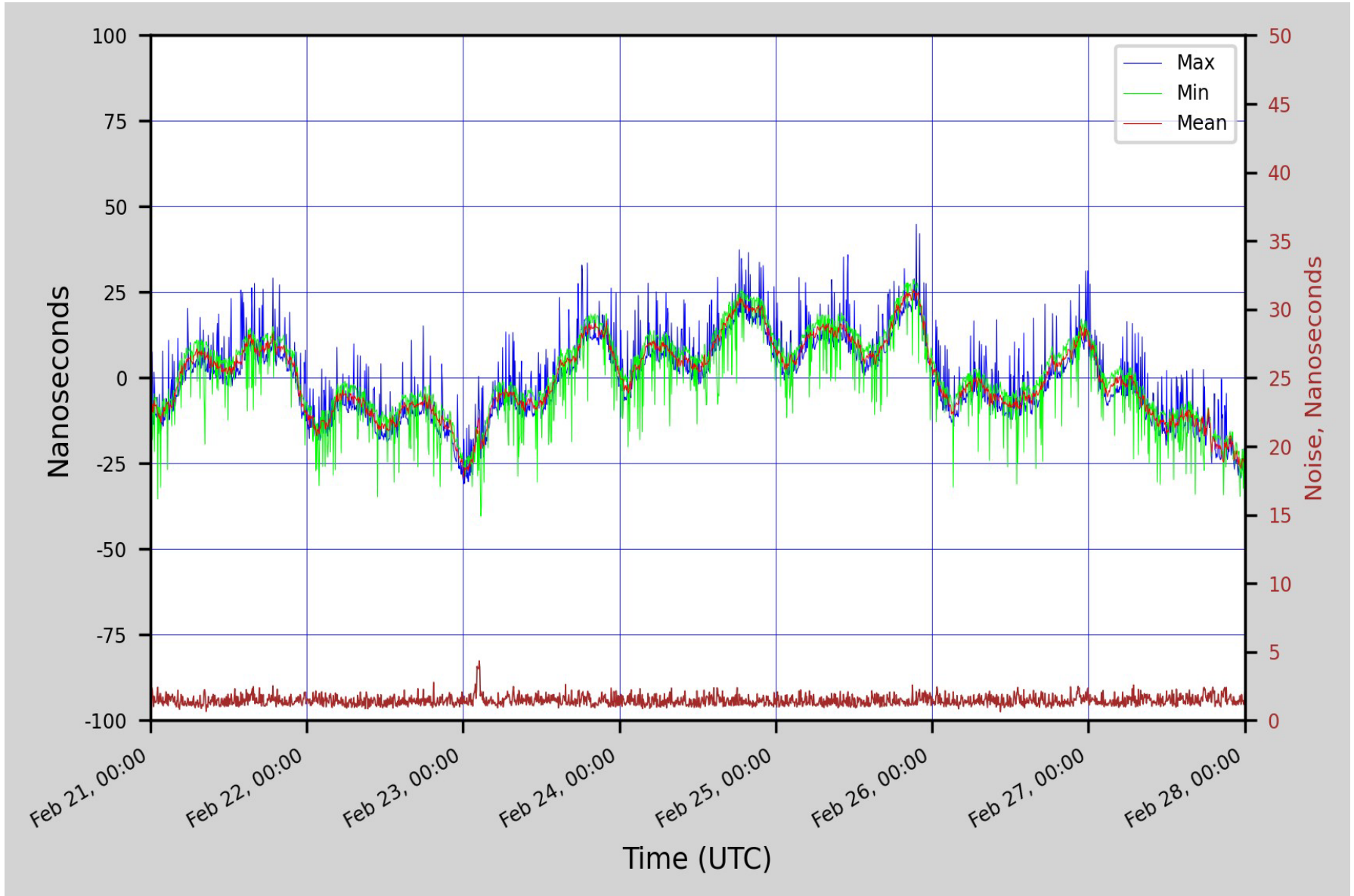

# CNS Clock "A" (M12+) vs. HP5065A (2816A) Noise Chart

Data logged by Tac32Plus. Analyzed by Python + Pandas on 01-Mar-2023, © 2023 CNS Systems, Inc.  
Software corrected 1PPS with 8 nsec RxDelay.

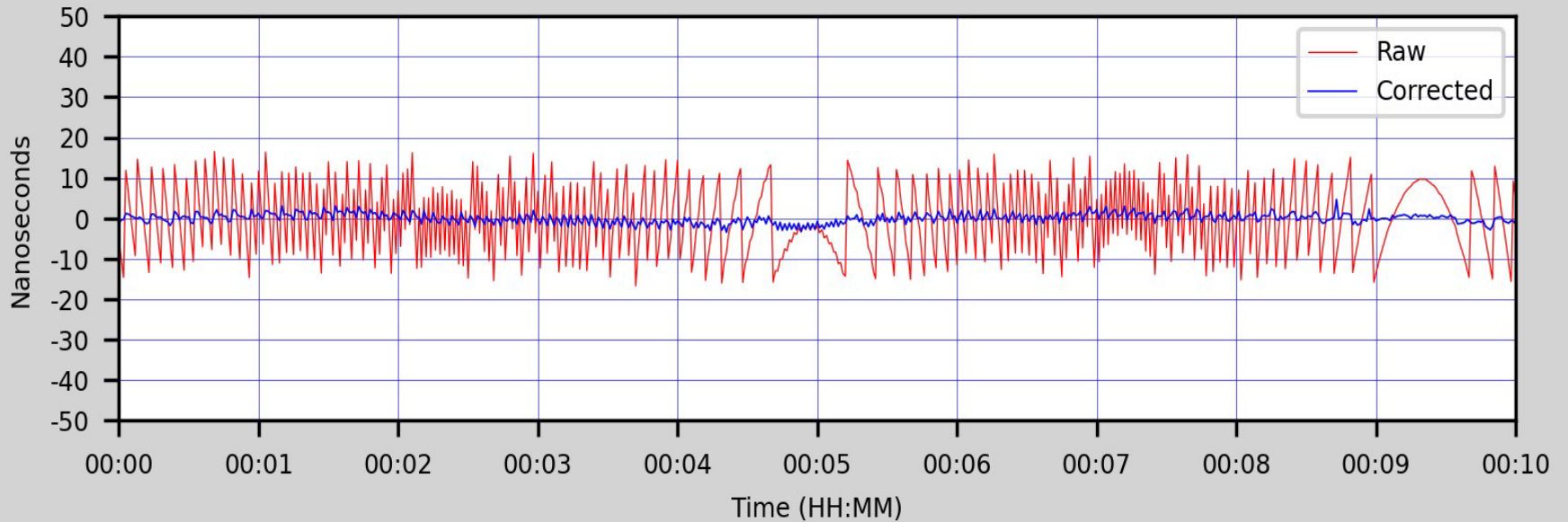
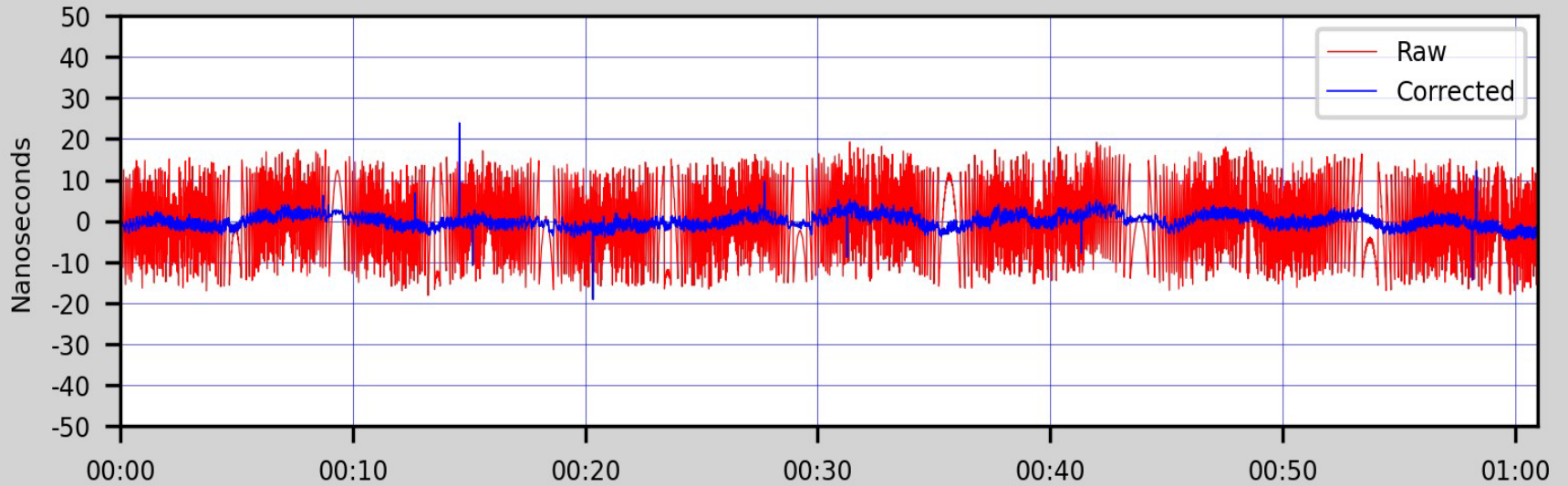

# CNS Clock II 404449 (SSR-M8F+) vs. HP5065A (2816A) Drift Chart

Data logged by Tac32Plus. Analyzed by Python + Pandas on 01-Mar-2023, © 2023 CNS Systems, Inc.

Averaging period is 300 seconds, Hardware corrected PPS with 48 nsec RxDelay.

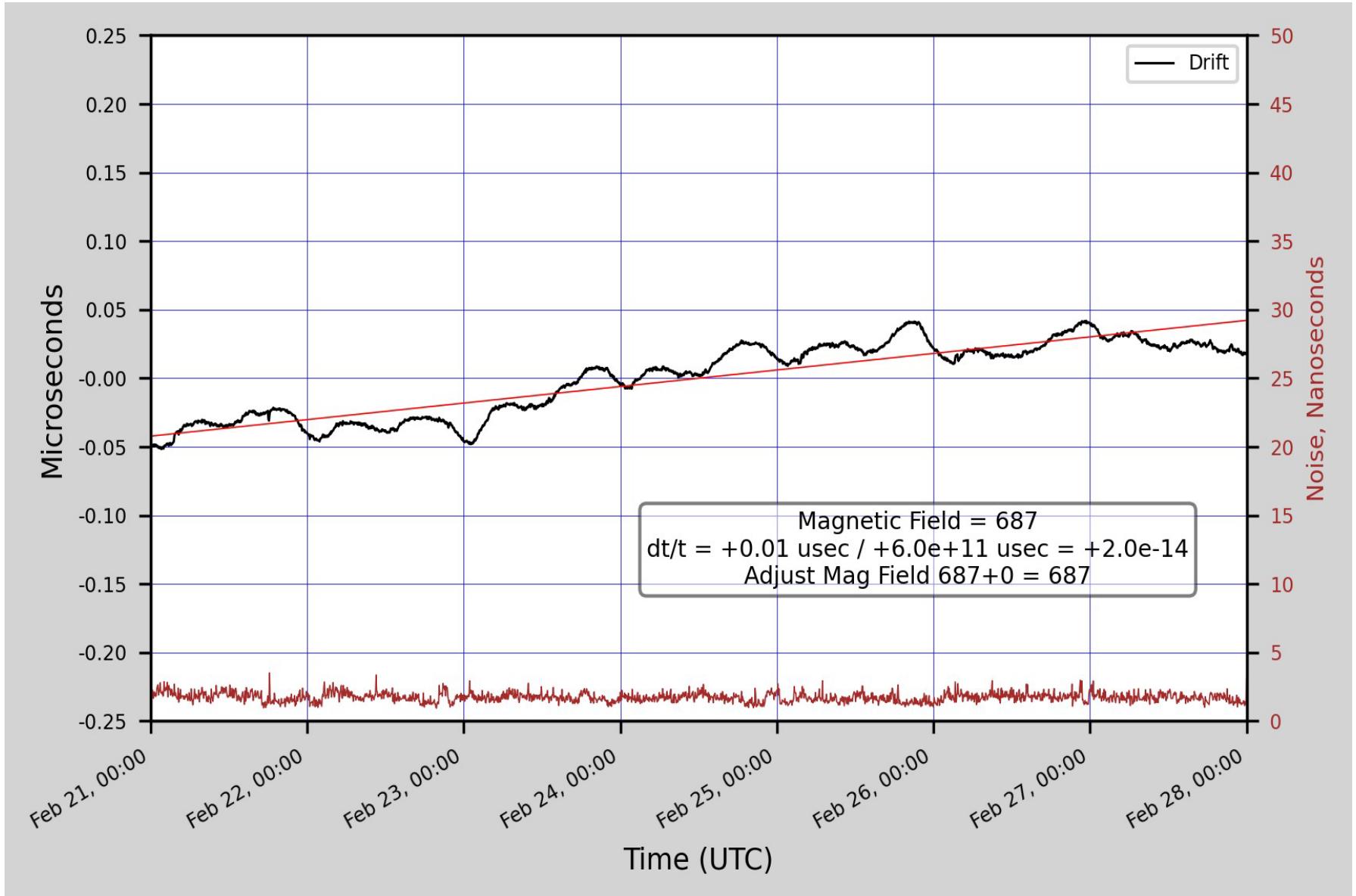

# CNS Clock II 404449 (SSR-M8F+) vs. HP5065A (2816A) Average Data Chart

Data logged by Tac32Plus. Analyzed by Python + Pandas on 01-Mar-2023, © 2023 CNS Systems, Inc.  
Averaging period is 300 seconds, Osc drift removed, Hardware corrected PPS with 48 nsec RxDelay.

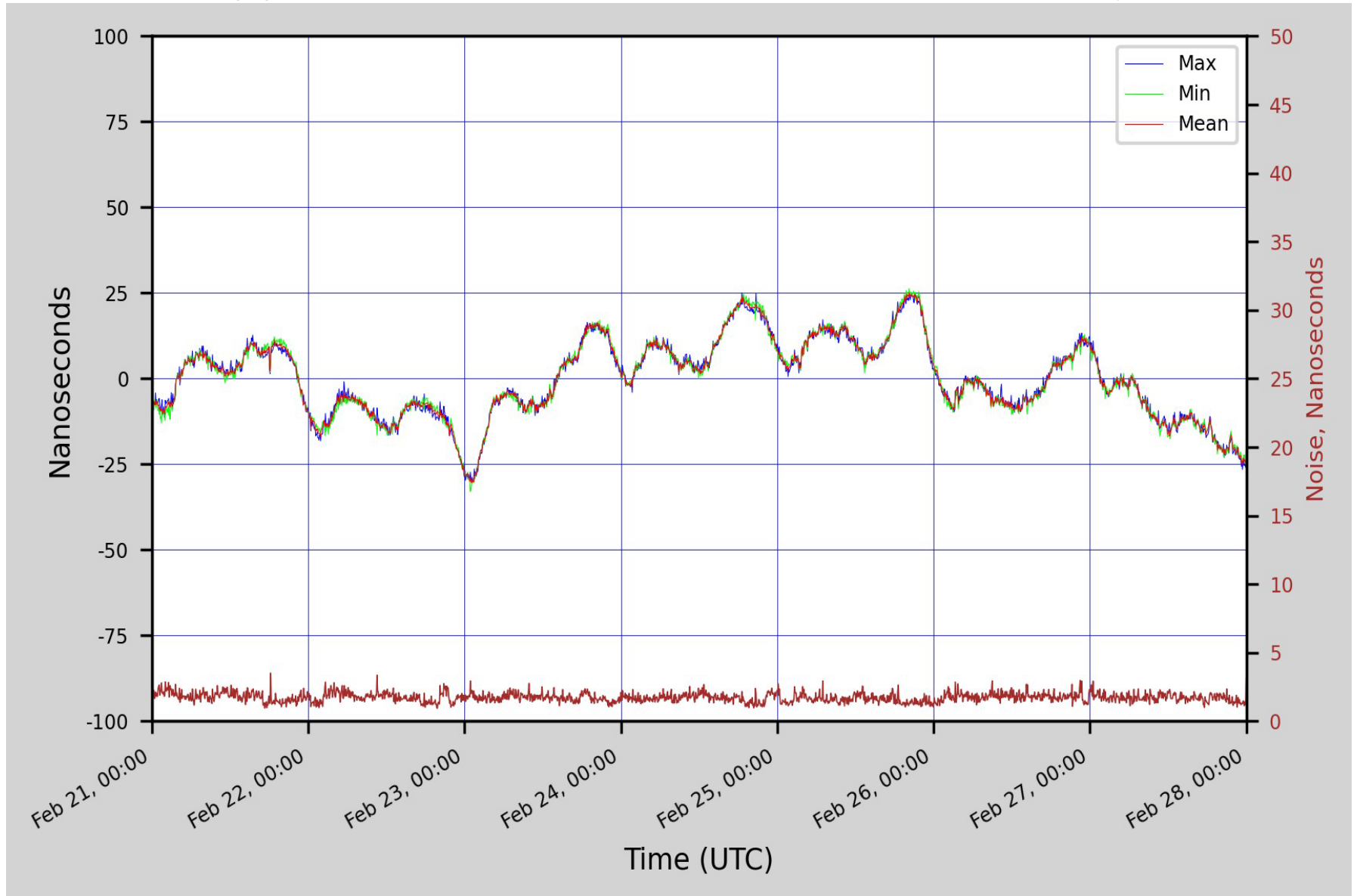



# CNS Clock II 404449 (SSR-M8F+) vs. HP5065A (2816A) Noise Chart

Data logged by Tac32Plus. Analyzed by Python + Pandas on 01-Mar-2023, © 2023 CNS Systems, Inc.

Hardware corrected PPS with 48 nsec RxDelay.

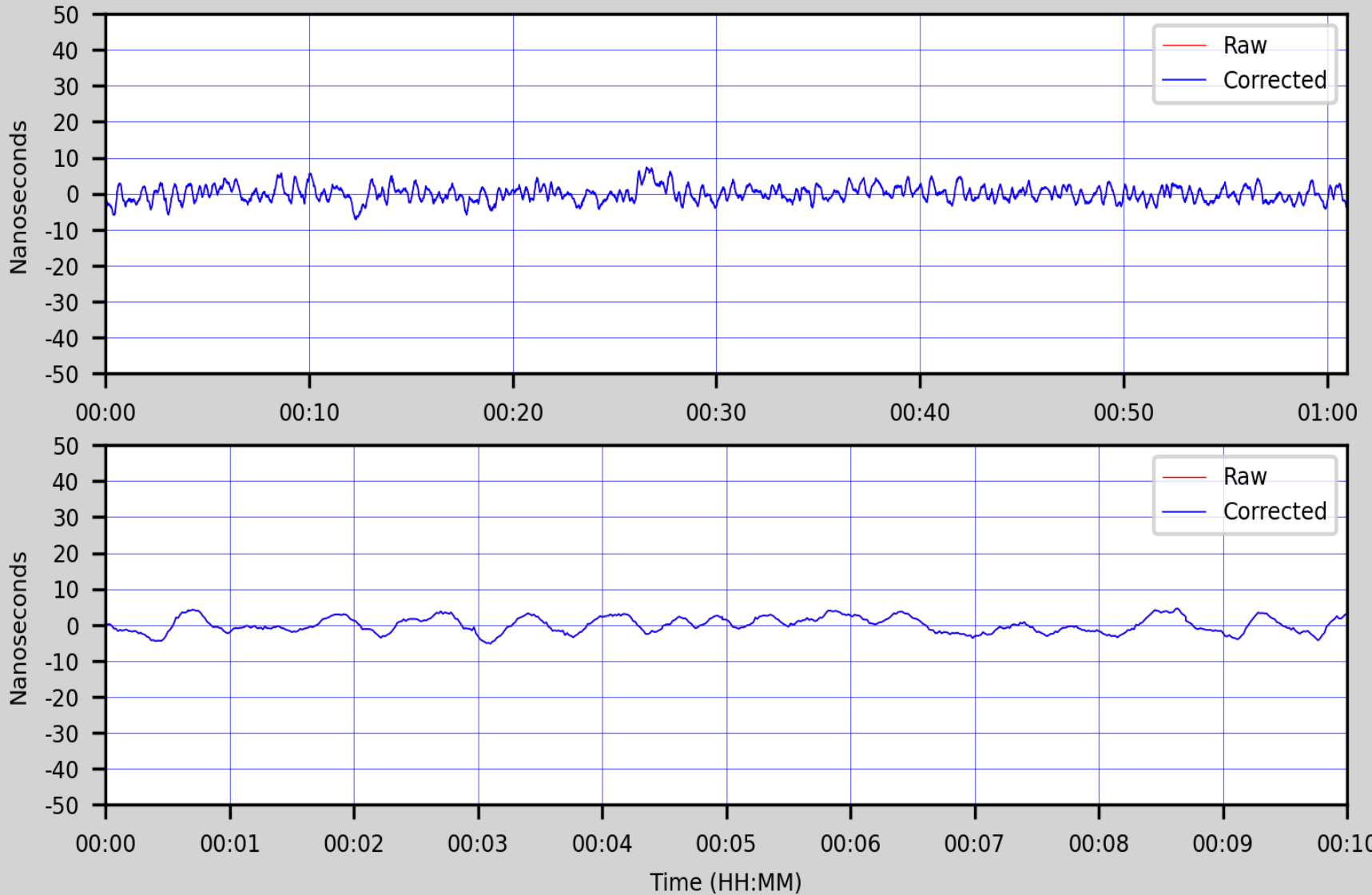

# CNS Clock II 404450 (SSR-M8F+) vs. HP5065A (2816A) Drift Charts

Data logged by Tac32Plus. Analyzed by Python + Pandas on 01-Mar-2023, © 2023 CNS Systems, Inc.

Averaging period is 300 seconds, Hardware corrected PPS with 48 nsec RxDelay.

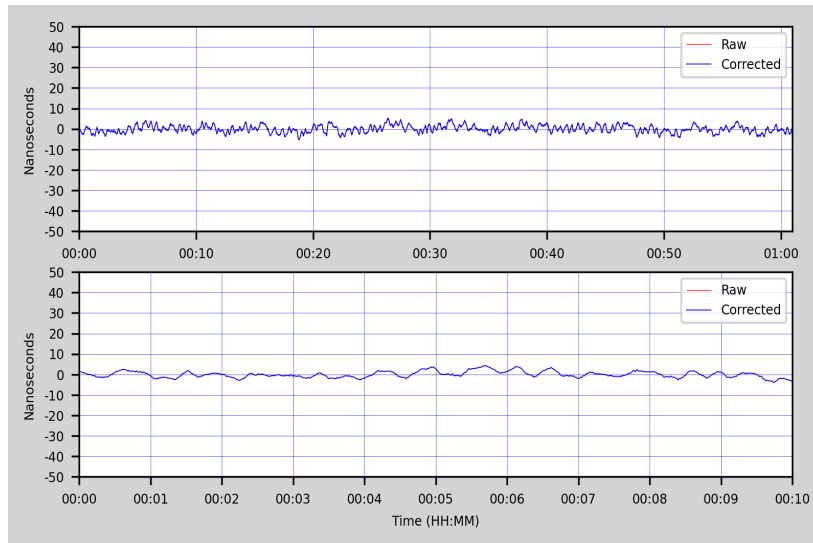
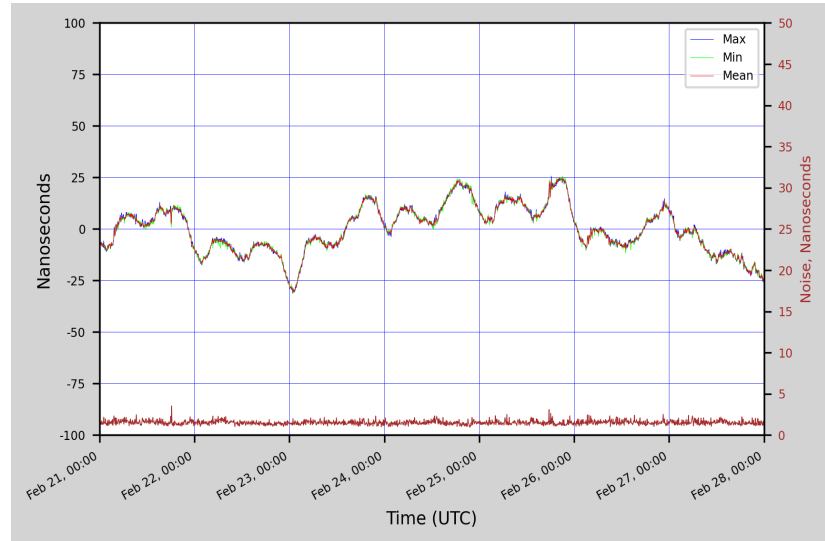
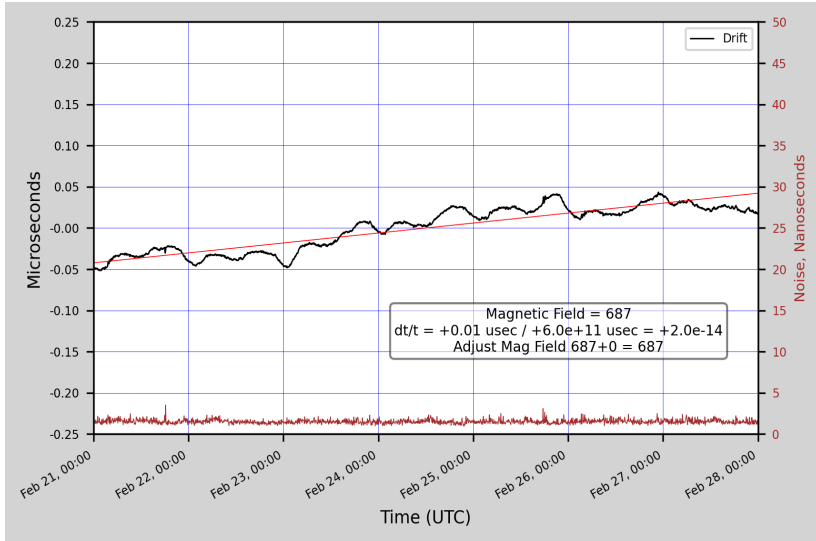

# CNS Clock II 404451 (SSR-M8F+) vs. HP5065A (2816A) Drift Charts

Data logged by Tac32Plus. Analyzed by Python + Pandas on 01-Mar-2023, © 2023 CNS Systems, Inc.

Averaging period is 300 seconds, Hardware corrected PPS with 48 nsec RxDelay.

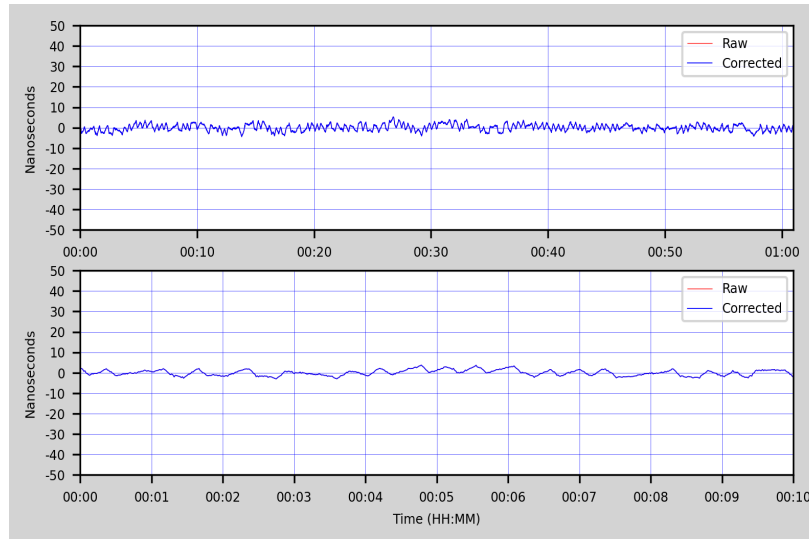
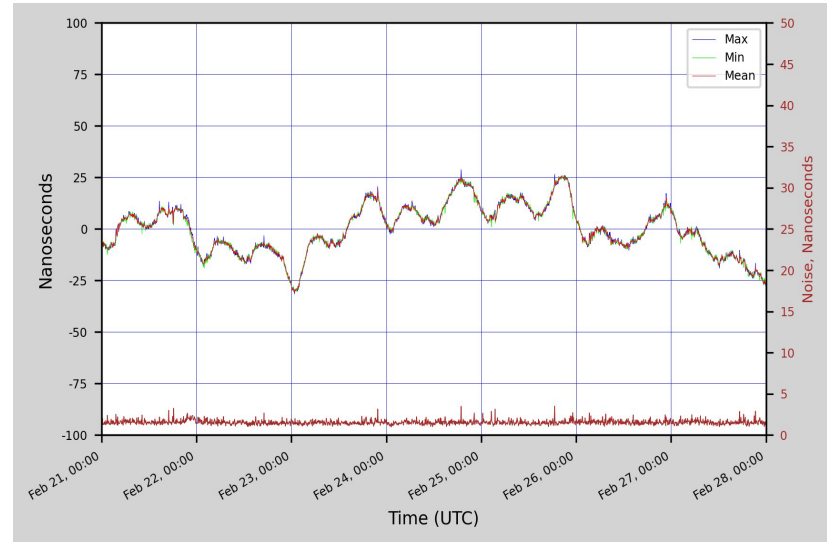
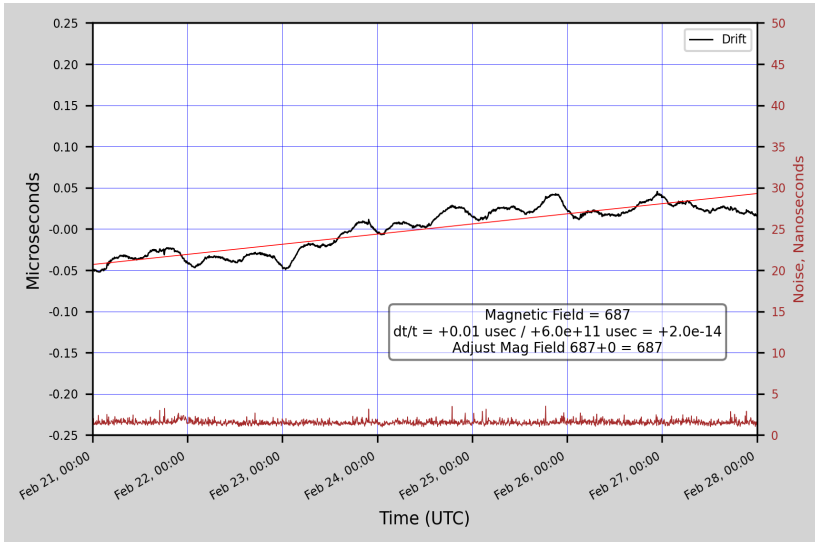

# GPS Receiver Comparison Data Charts

Data logged by Tac32Plus. Analyzed by Python + Pandas on 01-Mar-2023, © 2023 CNS Systems, Inc.

Averaging period is 300 seconds, Osc drift removed.

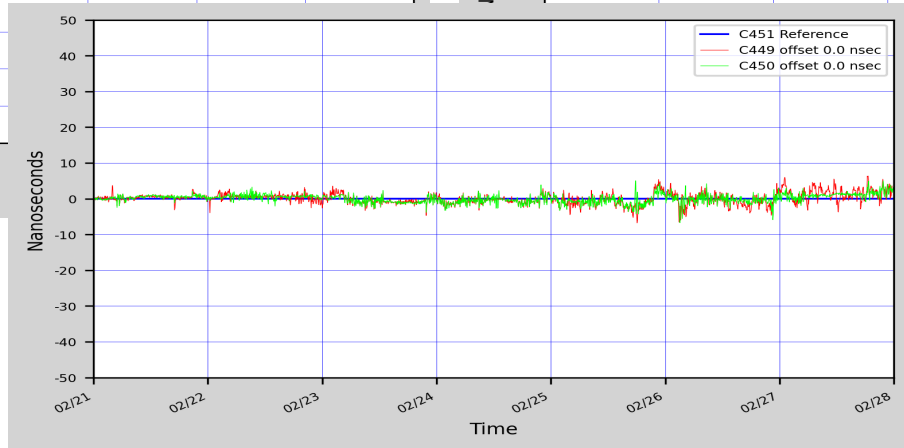
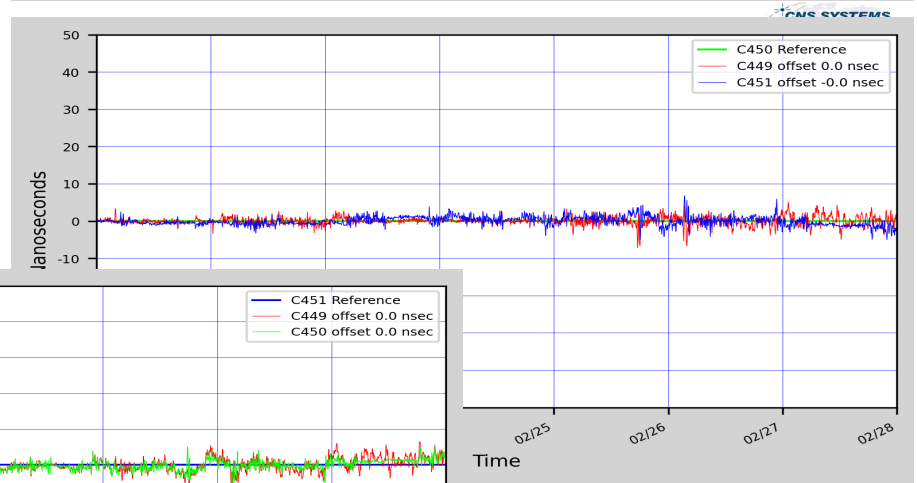
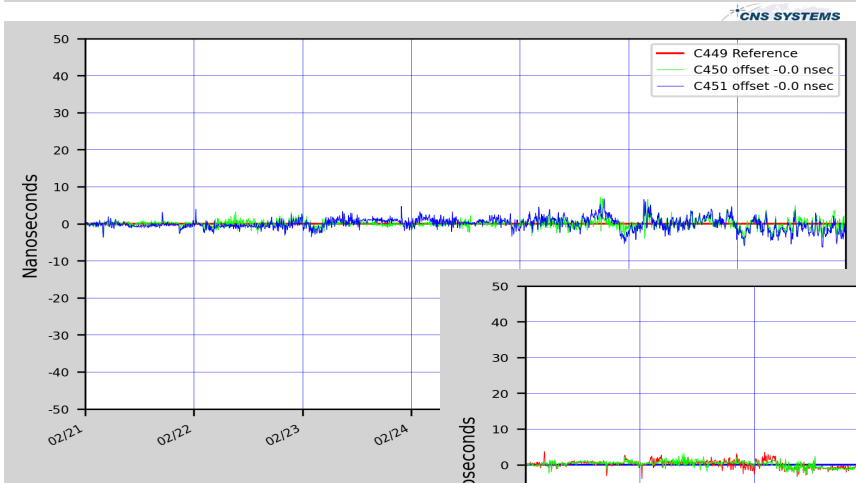
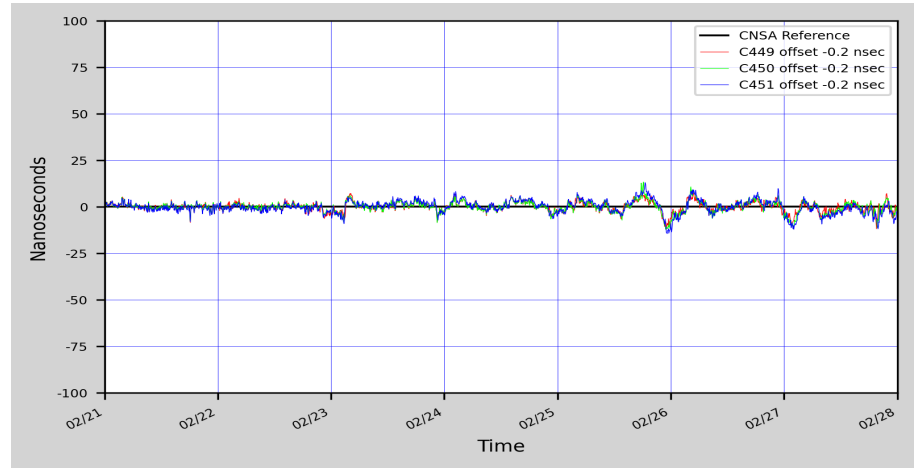
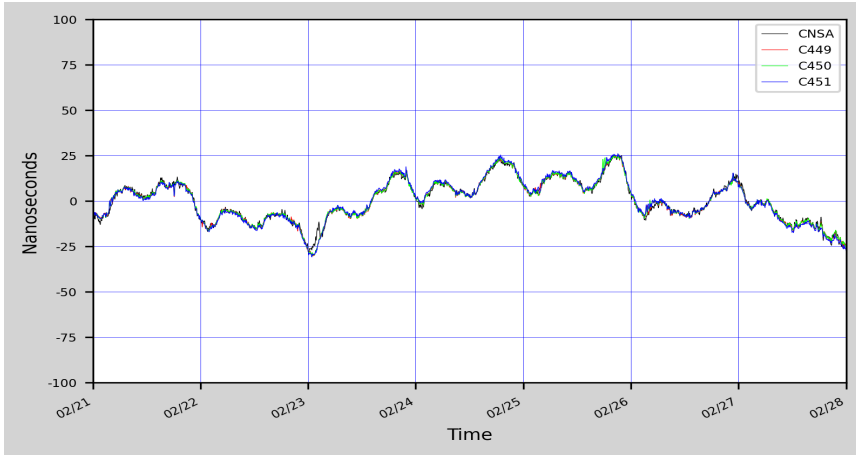

# Westford Time or Frequency Problem?

Now let us look at the Westford  
Data from February 2023

# GNSS Test Bed Analysis



## User Input

Data Directory containing the Tac32Plus or GPSTime data files

Output Directory for the report file

Enter the start time for the Average Data charts

Enter the duration (days) for the Average Data charts.

Enter the Average Data sample size  
 <- This is needed to validate each data line

Enter the Time (noise) data start time.  
 <- Note that the one hour block of data must be in a single data file

Enter the Magnetic Field Setting (optional).  
 <- This is for an HP5064A Rubidium Standard. If not needed, set blank or zero.

**Data sets to include in the report**

	Enter the Prefix for the data file series	Enter the Primary Header	Enter the Secondary Header Extension
<input checked="" type="checkbox"/>	<input type="text" value="04WF"/>	<input type="text" value="CNS Clock 801038 (M12M) vs. Westford Maser"/>	<input type="text" value="Software corrected 1PPS with 8 nsec RxDelay."/>
<input type="checkbox"/>	<input type="text"/>	<input type="text"/>	<input type="text"/>
<input type="checkbox"/>	<input type="text"/>	<input type="text"/>	<input type="text"/>
<input type="checkbox"/>	<input type="text"/>	<input type="text"/>	<input type="text"/>

# CNS Clock 801038 (M12M) vs. Westford Maser Drift Chart

Data logged by Tac32Plus. Analyzed by Python + Pandas on 01-Mar-2023, © 2023 CNS Systems, Inc.  
Averaging period is 300 seconds, Software corrected 1PPS with 8 nsec RxDelay.

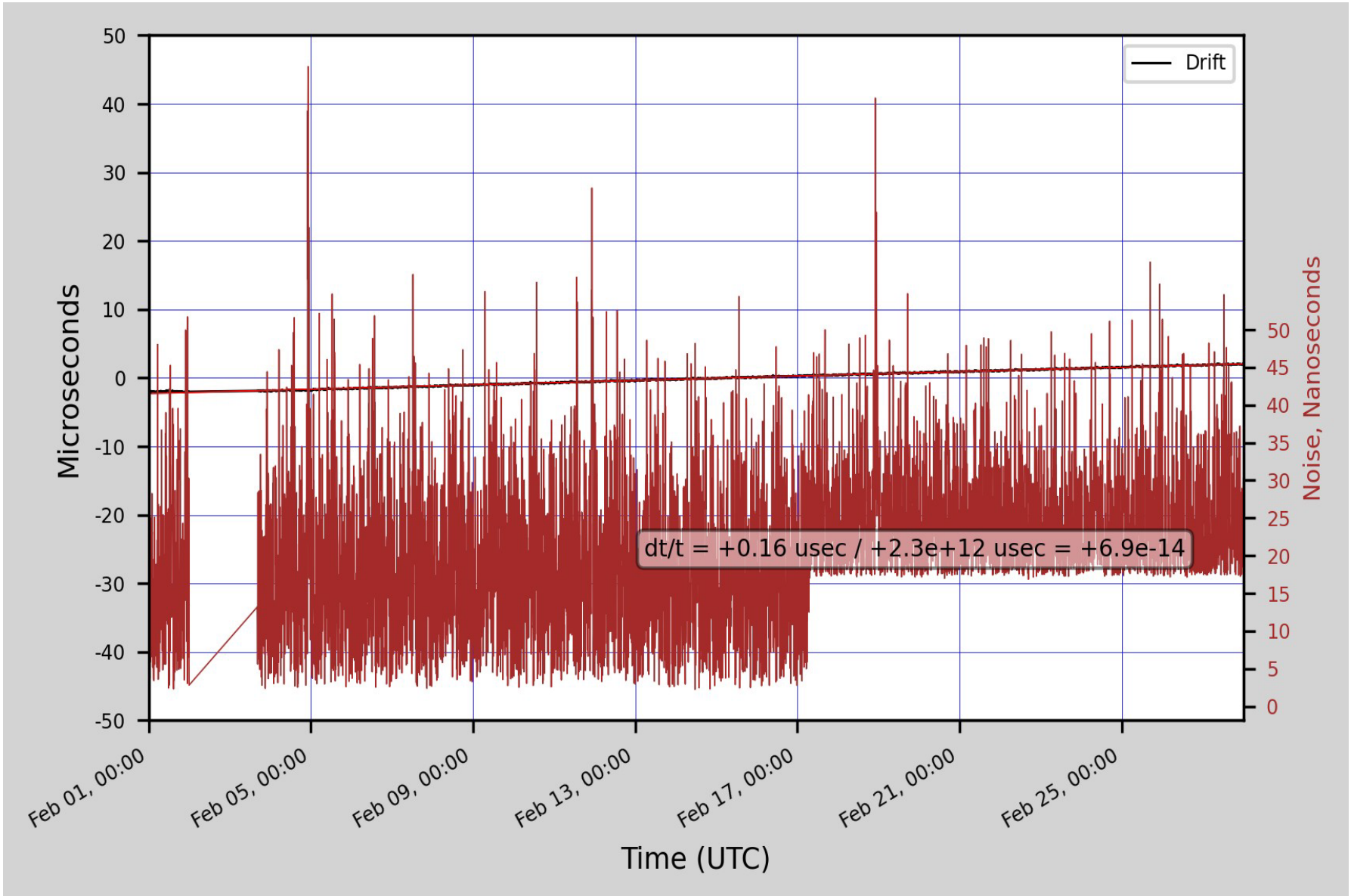

# CNS Clock 801038 (M12M) vs. Westford Maser Average Data Chart

Data logged by Tac32Plus. Analyzed by Python + Pandas on 01-Mar-2023, © 2023 CNS Systems, Inc.  
Averaging period is 300 seconds, Osc drift removed, Software corrected 1PPS with 8 nsec RxDelay.

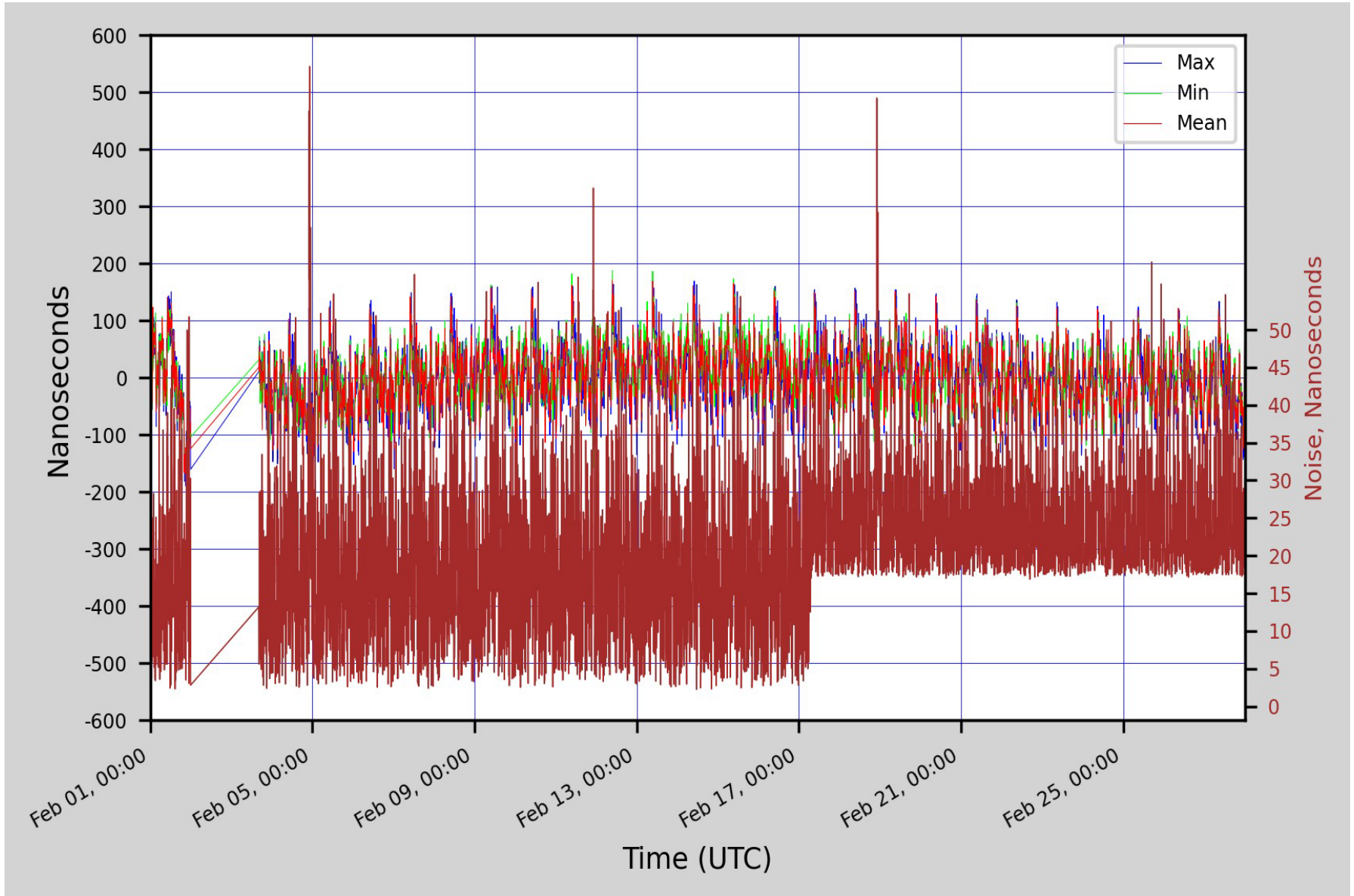



# CNS Clock 801038 (M12M) vs. Westford Maser Noise Chart

Data logged by Tac32Plus. Analyzed by Python + Pandas on 01-Mar-2023, © 2023 CNS Systems, Inc.  
Software corrected 1PPS with 8 nsec RxDelay.

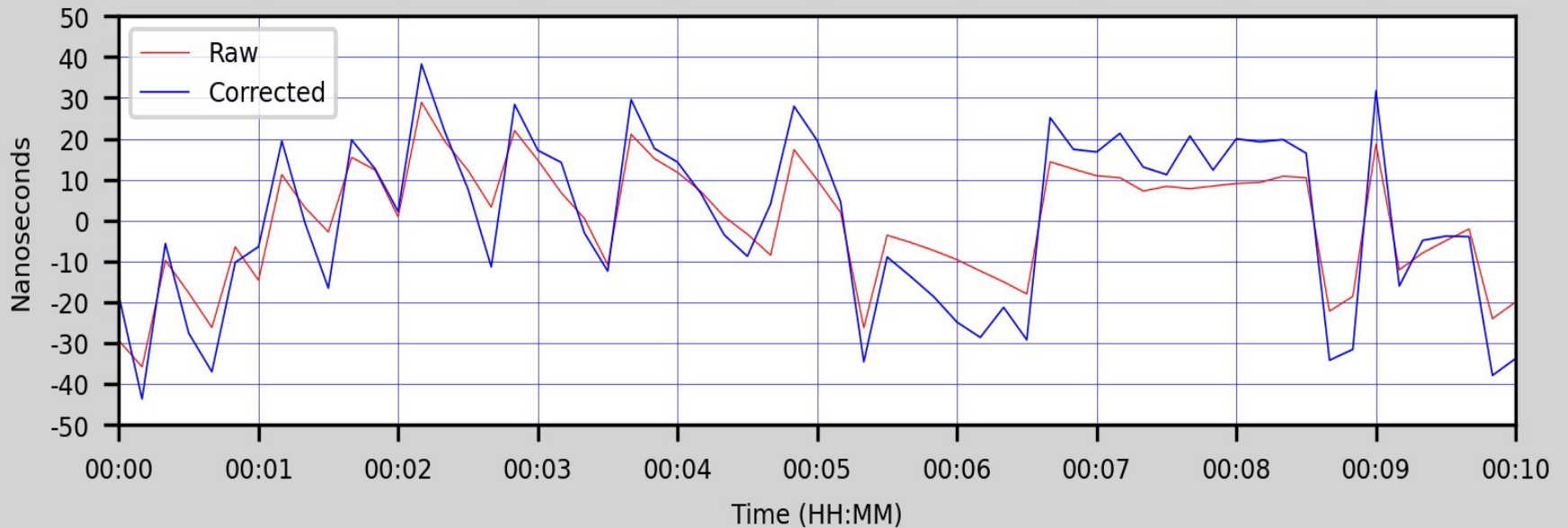
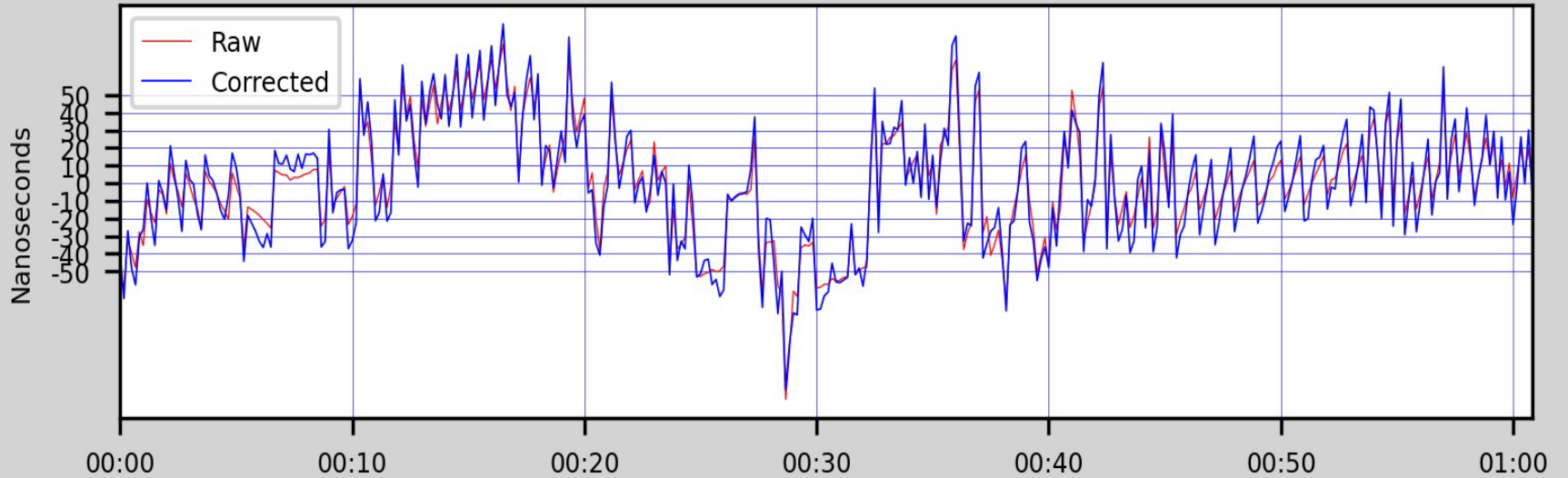

# Westford's old CNS Clock 801038 (M12M)

- The CNS Clock at Westford is part of a closed loop system designed to detect failures of the H-maser
- The CNS Clock at Westford is an original “TAC” design and has no internal PPS quantization correction or other features.
  - It was purchased in Feb-1999. It originally had a Motorola VP 8-channel GPS receiver.
  - It was upgraded in Aug-2017 with new front and rear panels and an M12M 12-channel GPS receiver module.
- To evaluate the Westford data, we need to understand the data produced by this old receiver.
- With the following understanding, it is likely that the GPS module in this CNS Clock is not working correctly. However, it also could be a problem with the Time Interval Counter.

# GGAO has a Similar Problem

Let's look at GGAO Data from  
March 2023

# GNSS Test Bed Analysis



Data Directory containing the Tac32Plus or GPSTime data files

Output Directory for the report file

Enter the start time for the Average Data charts

Enter the duration (days) for the Average Data charts.

Enter the Average Data sample size  
 <- This is needed to validate each data line

Enter the Time (noise) data start time.  
 <- Note that the one hour block of data must be in a single data file

Enter the Magnetic Field Setting (optional).  
 <- This is for an HP5064A Rubidium Standard. If not needed, set blank or zero.

**Data sets to include in the report**

	Enter the Prefix for the data file series	Enter the Primary Header	Enter the Secondary Header Extension
<input checked="" type="checkbox"/>	<input type="text" value="GS00"/>	<input type="text" value="CNS Clock 801041 vs. Maser at GGAO,"/>	<input type="text" value="Software corrected 1PPS with 8 nsec RxDelay."/>
<input type="checkbox"/>	<input type="text"/>	<input type="text"/>	<input type="text"/>
<input type="checkbox"/>	<input type="text"/>	<input type="text"/>	<input type="text"/>
<input type="checkbox"/>	<input type="text"/>	<input type="text"/>	<input type="text"/>

# CNS Clock 801041 vs. Maser at GGAO, Drift Chart

Data logged by Tac32Plus. Analyzed by Python + Pandas on 05-Apr-2023, © 2023 CNS Systems, Inc.  
Averaging period is 300 seconds, Software corrected 1PPS with 8 nsec RxDelay.

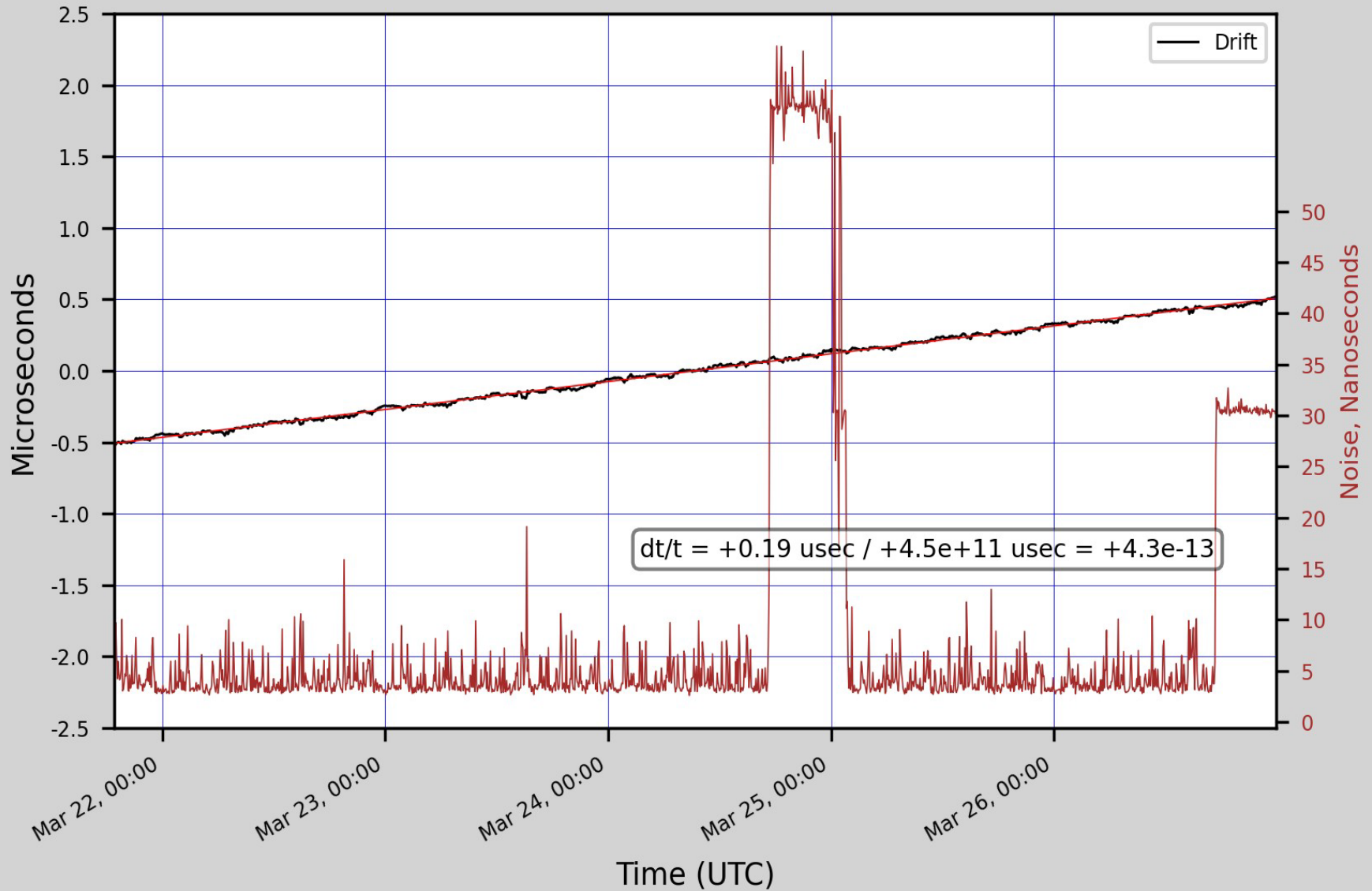

# CNS Clock 801041 vs. Maser at GGAO, Average Data Chart

Data logged by Tac32Plus. Analyzed by Python + Pandas on 05-Apr-2023, © 2023 CNS Systems, Inc.  
Averaging period is 300 seconds, Osc drift removed, Software corrected 1PPS with 8 nsec RxDelay.

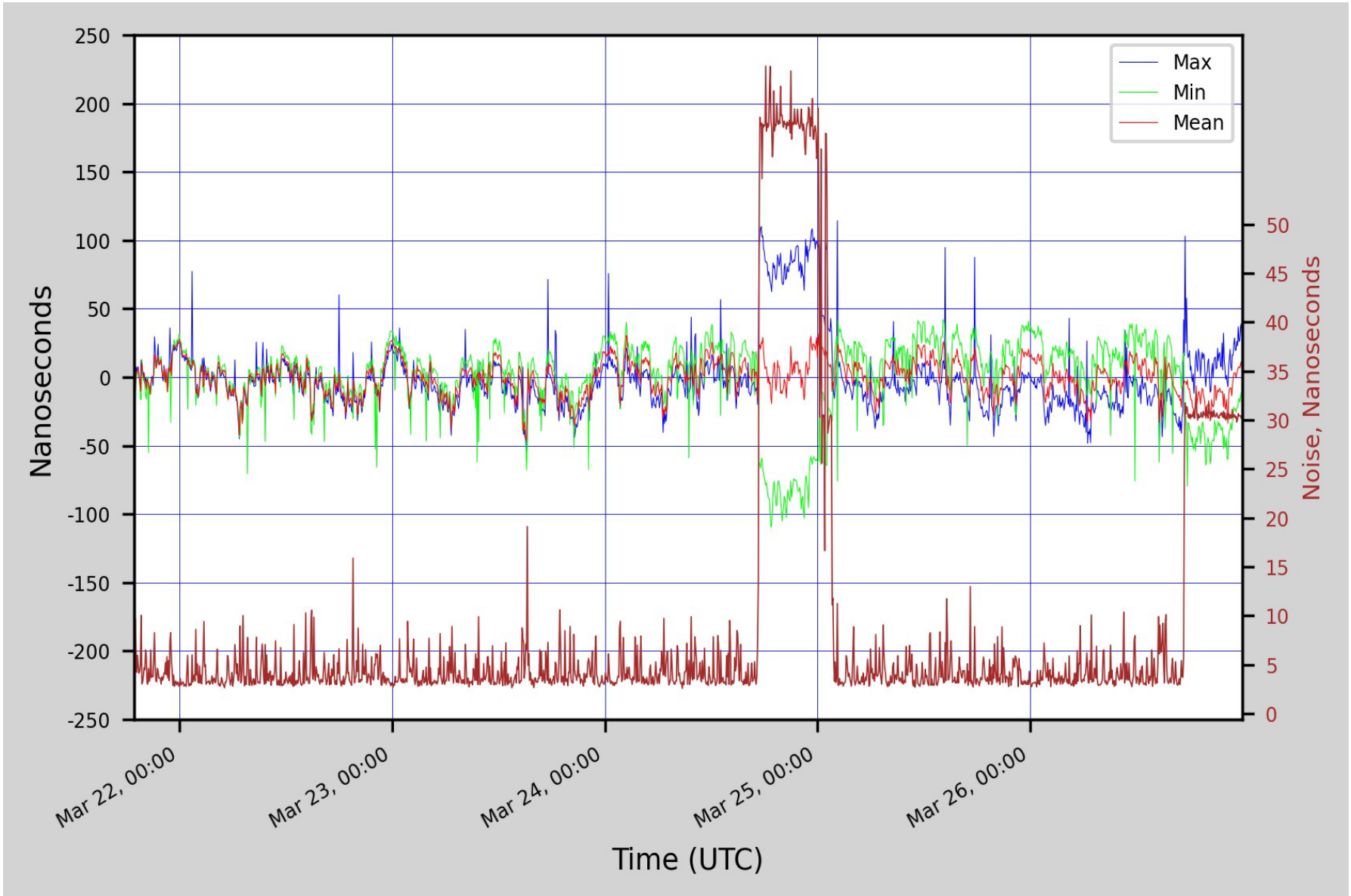

# CNS Clock 801041 vs. Maser at GGAO, Noise Chart

Data logged by Tac32Plus. Analyzed by Python + Pandas on 05-Apr-2023, © 2023 CNS Systems, Inc.  
Software corrected 1PPS with 8 nsec RxDelay.

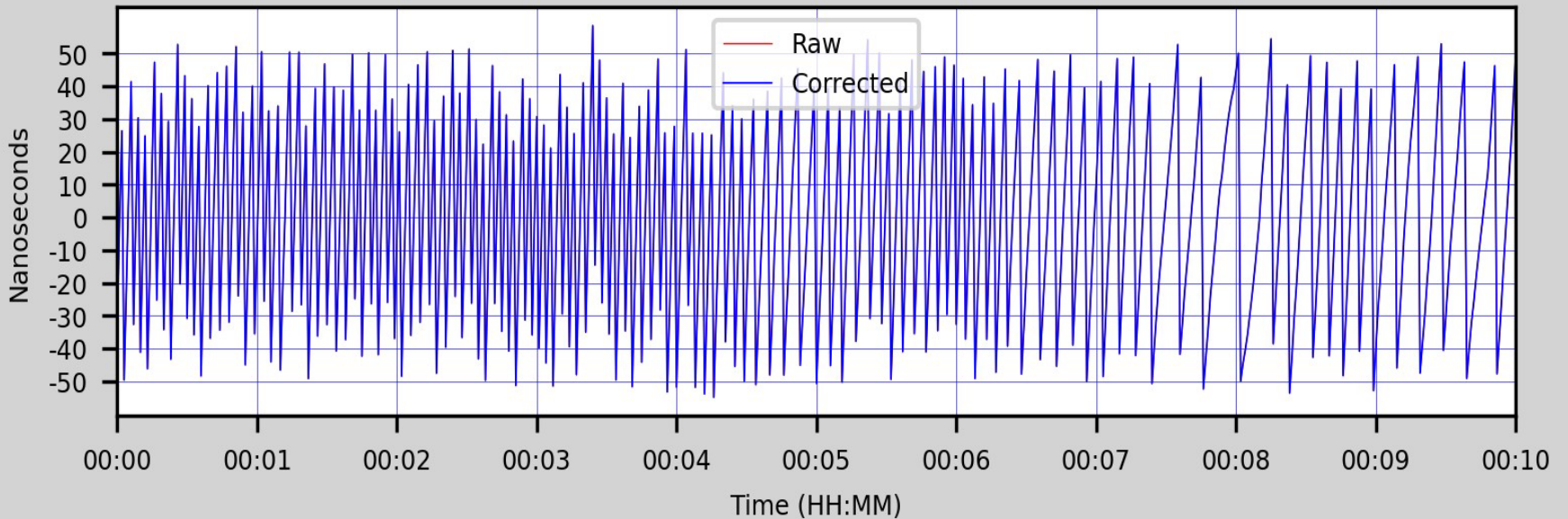
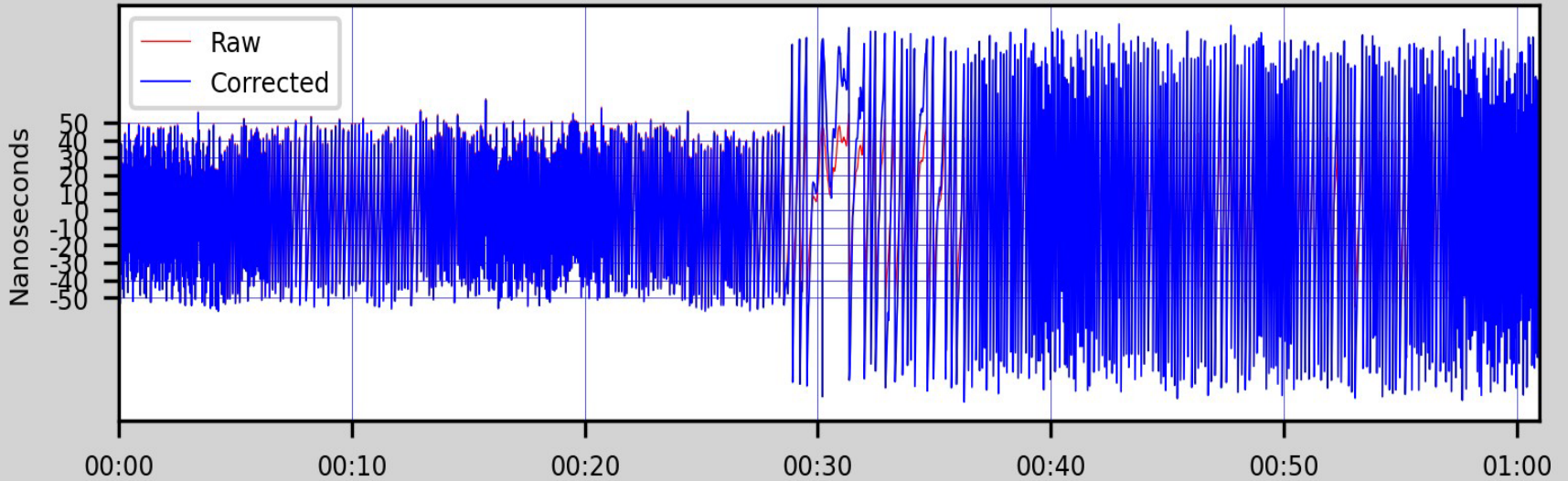

# An Example of 1PPS Quantization Error Correction

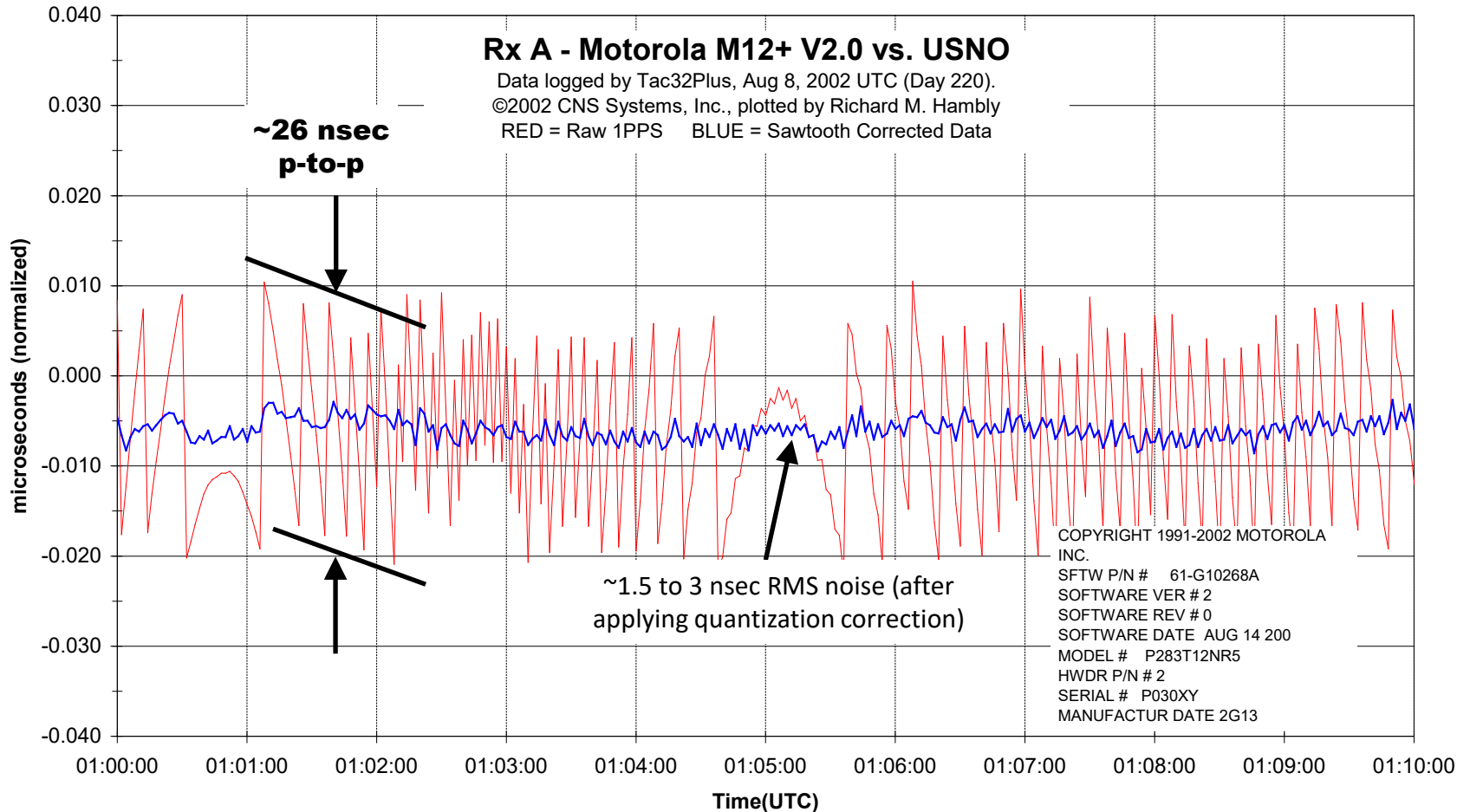



# Now let's discuss . . .

- Week rollover may mean retiring old GPS receivers (Motorola VP, UT+, etc.)
  - “We have legacy equipment using the Oncore VP. We have found that the VP receivers have a cutoff date after which the date reverts back 1024 weeks.” The compile date of v10.0 was 24-Sep-1999 => rollover is 10-May-2019.
- GPS receiver quantization error (“sawtooth”).
- “Absolute” Receiver Calibration
- New developments
  - The SSR-M8T GNSS receiver
  - Tac32Plus updates
  - CNS Clock II improvements (NTP, Oscillator, PPS)

# What Causes the Quantization Error ?

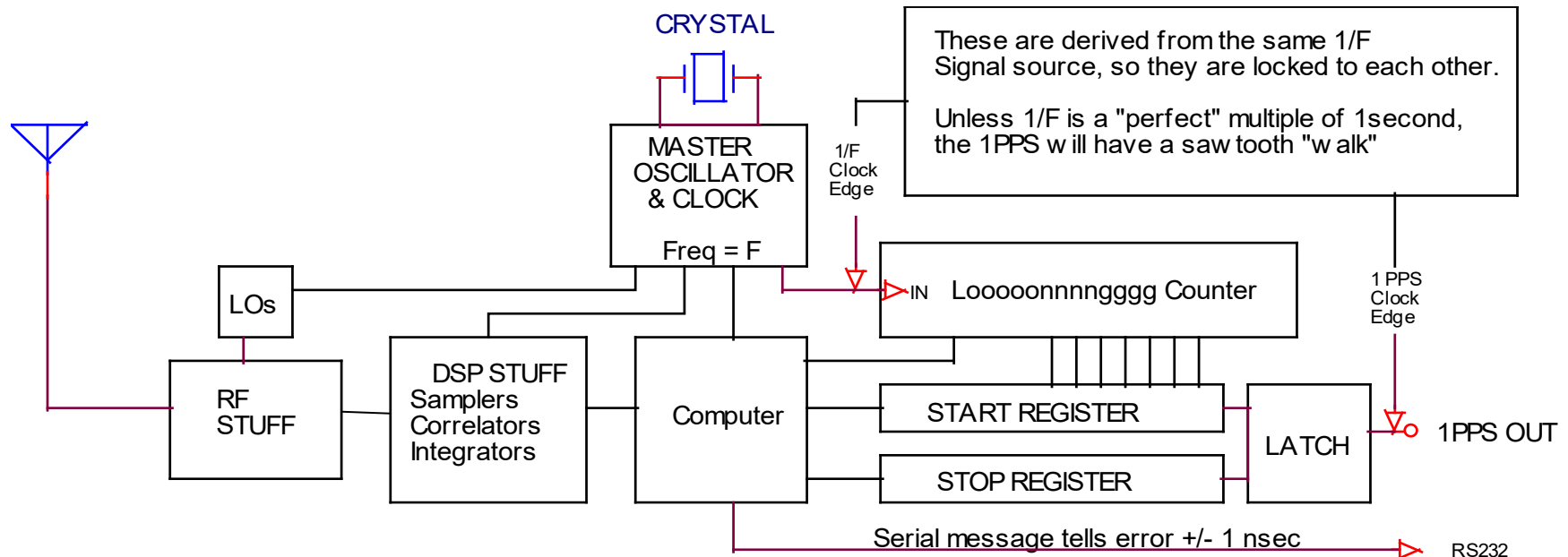

- For the older VP, UT+ Oncore,  $F=9.54$  MHz, so the  $1/F$  quantization error has a range of  $\pm 52$  nsec (104 nsec peak-to-peak).
- The M12+ & M12M have  $F \approx 40$  MHz, so the quantization error has been reduced to  $\pm 12.5$  nsec (25 nsec).
- SSR-M8T has  $F \approx 30.72 * 2 = 61.44$  MHz, so the quantization error has been reduced to  $\pm 8$  nsec (16 nsec).

# VLBI's Annoying Problem Caused by the Quantization Timing Error

- When the formatter (Mark 5/6 sampler) needs to be reset, you have to feed it a 1PPS timing pulse to restart the internal VLBI clock. After it is started, it runs smoothly at a rate defined by the Maser's 5/10 MHz.
- The **AVERAGE** of the 1PPS pulses from the GPS receiver is “correct”, but any single pulse can be in error by  $\pm 52$ ,  $\pm 13$ , or  $\pm 8$  nsec because of the quantization error.
- Once you have restarted the formatter with the noisy 1 PPS signal, you then measure the actual (GPS minus Formatter) time that you achieved.
- Or you can use the 1PPS from a CNS Clock II which has the quantization error removed.

# How can quantization noise be eliminated ?

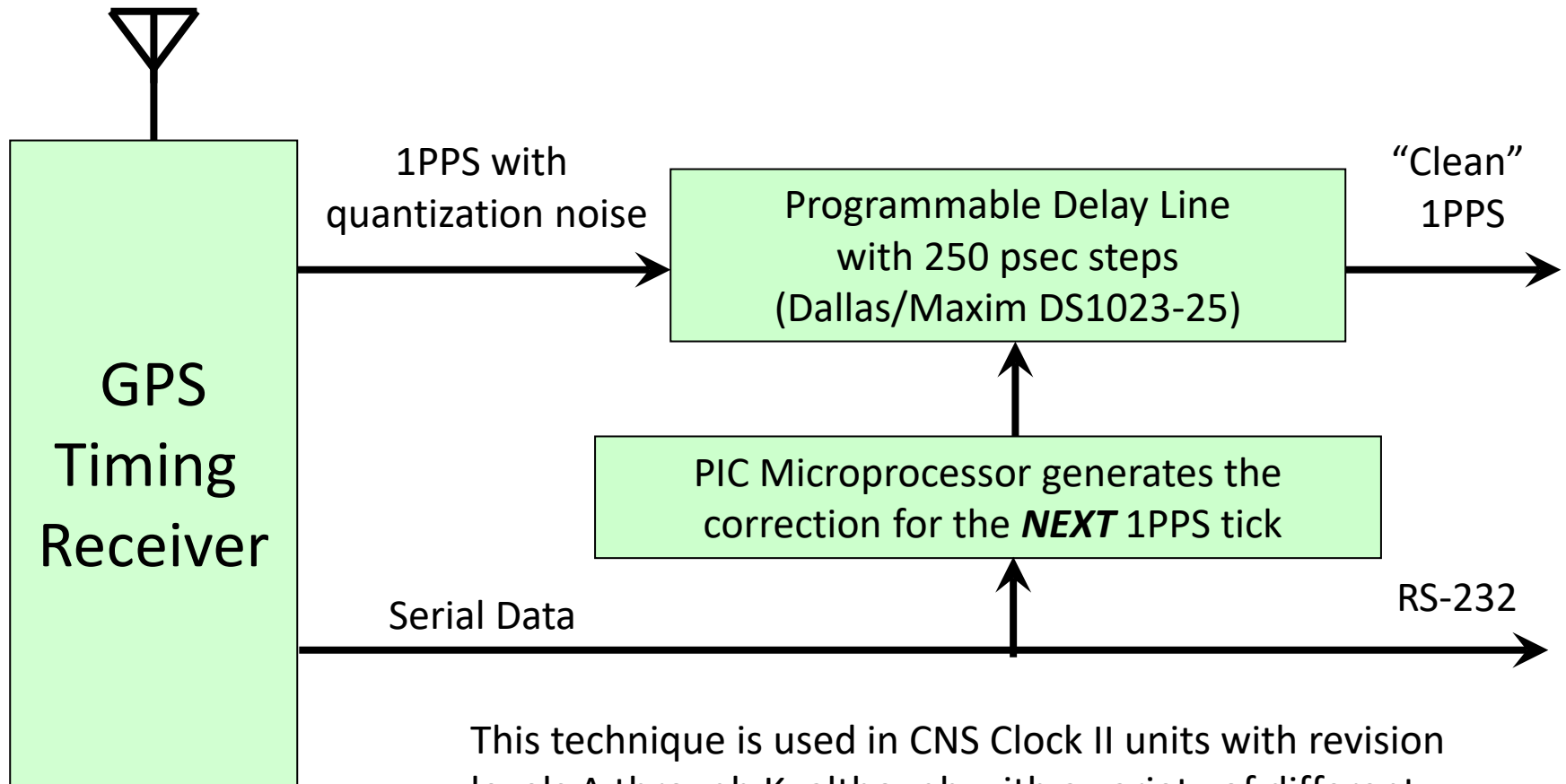

This technique is used in CNS Clock II units with revision levels A through K, although with a variety of different delay line types and step values.

# How else can quantization noise be eliminated ?

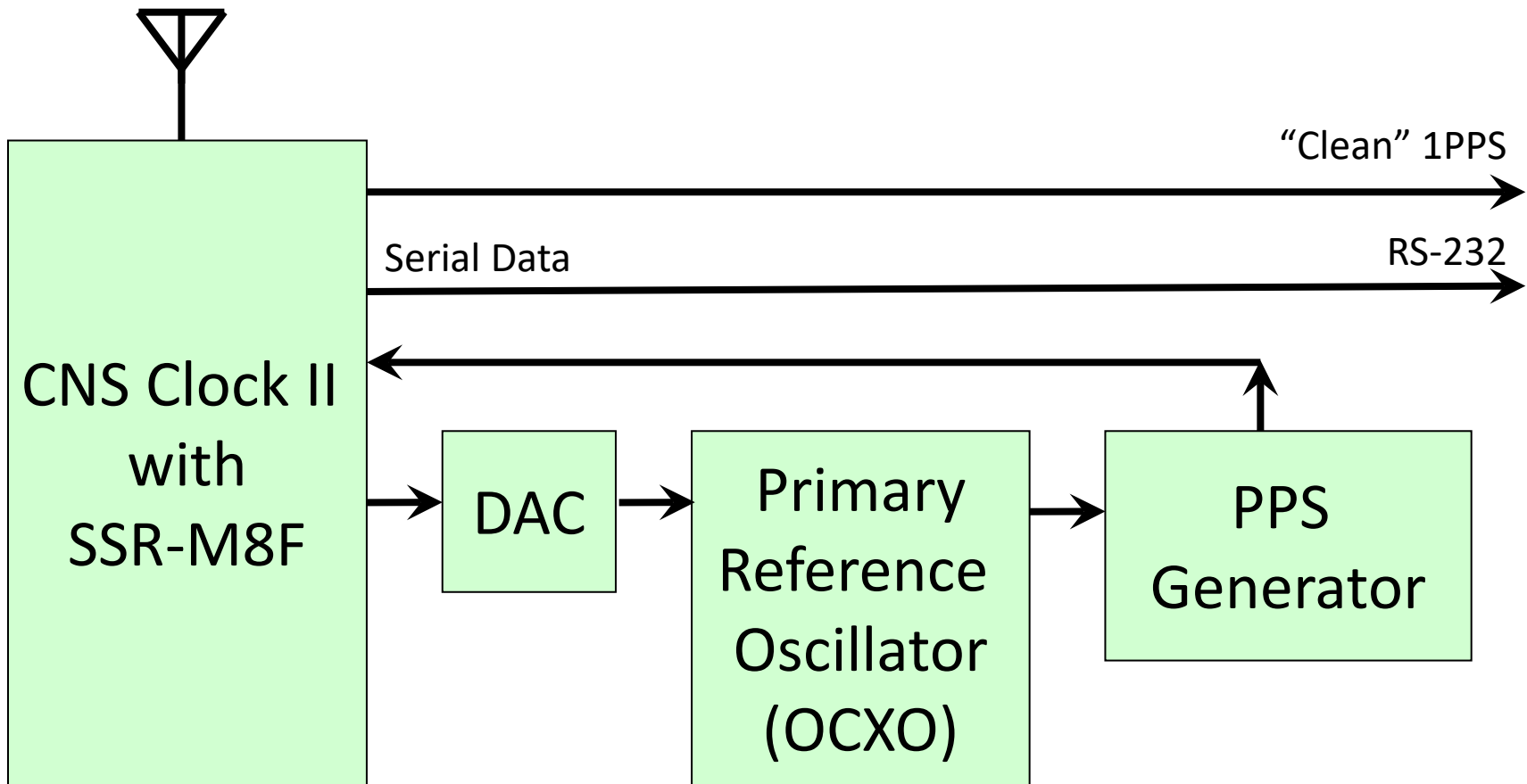

This technique is used in CNS Clock II units, beginning with revision L. Among other benefits, this provides holdover with synchronized date and time for better NTP and IRIG-B performance. The PPS stability is better than the delay line version.

# The CNS Clock continues to Evolve

1994 – 2004: the TAC



Available Since January 2005, now at Revision M



- Data available on RS-232, USB, Ethernet, RS-485 and solid-state relay ports.
- Ethernet NTP Server.
- TNC GPS Antenna Connector.
- Buffered 1 PPS outputs.
- GPS Steered OCXO  
10 (or 5) MHz output.
- High Performance PPS.
- IRIG-B
- Good holdover performance

# CNS Clock and CNS Clock II Setup Note

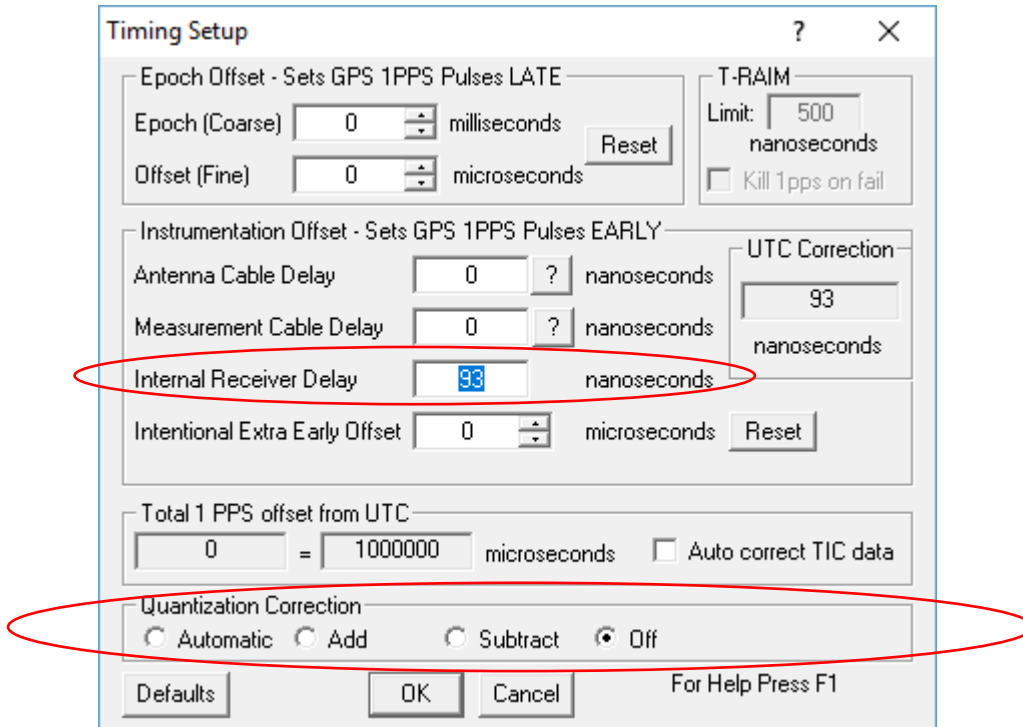

Revision	Serial Number Range		Internal Receiver Delay (nanoseconds)
CNS Clock (original)	801001	801455	8
CNS Clock II Rev A	n/a	n/a	
Rev B	404001	404028	53 (estimated)
Rev C	n/a	n/a	53 (estimated)
Rev D	404029	404055	53 (estimated)
Rev E	404056	404108	53 (estimated)
Rev F	404109	404159	53 (estimated)
Rev G	404160	404265	53 (estimated)
Rev H	404266	404138	53 (estimated)
Rev I	404319	404344	97 (estimated)
Rev J	404345	404371	97
Rev K	404372	404398	97
Rev L	404399	404425	48
Rev M	404426		48

- The current CNS Clock internal delay is set using the table in the latest instruction manual, available online. This offset is removed by setting the parameter in Tac32Plus or GPSTime.
- CNS Clock II units perform quantization correction in hardware so the software correction should be set to “Off”.

# Does the hardware 1PPS correction work?

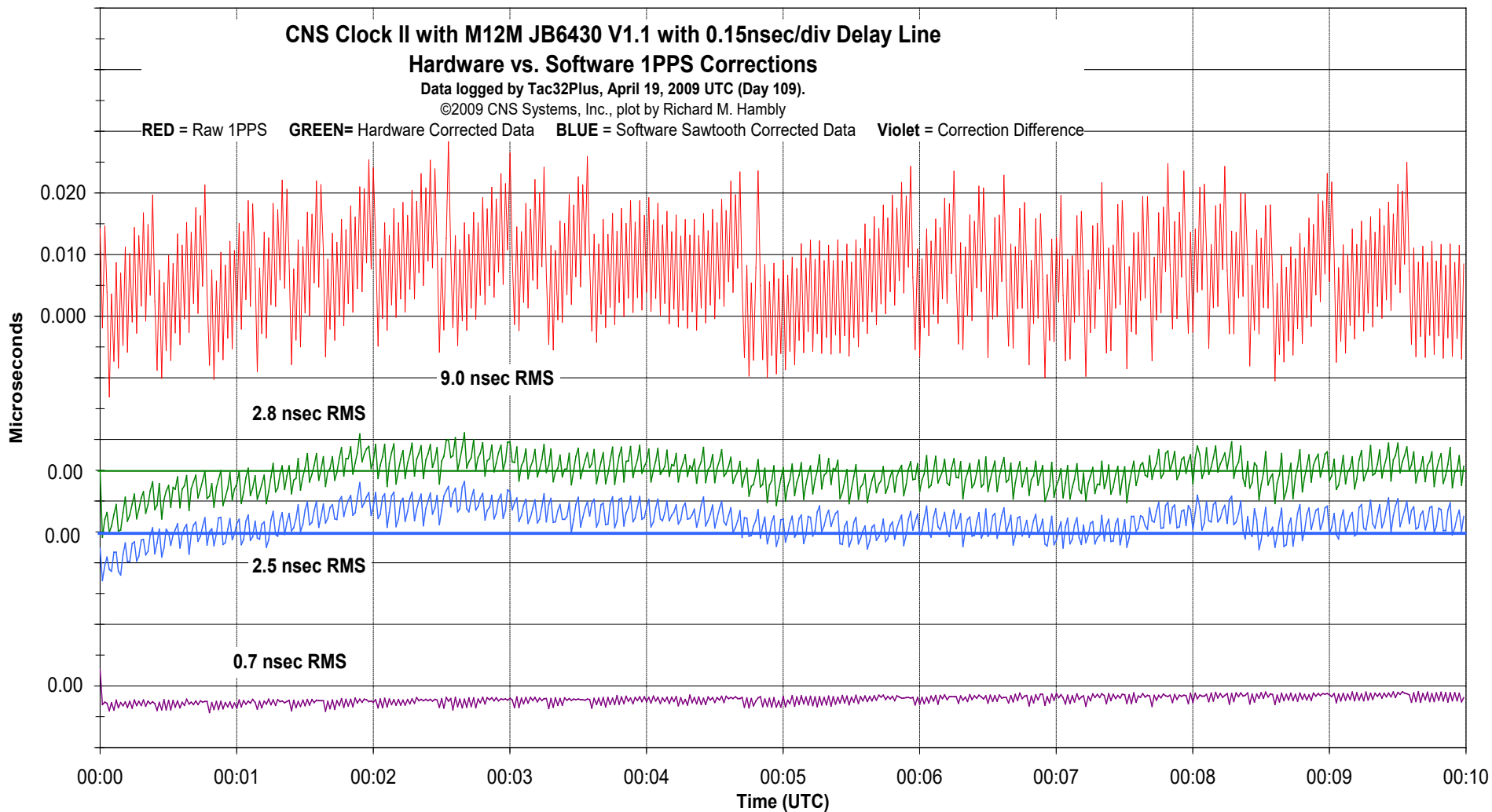



# CNS Systems' Test Bed at USNO

Calibrating the UTC Offset (ACCURACY) of M12+ receivers with 2.0 Firmware.

We observed that the "Oncore" firmware evolution from 5.x  $\Rightarrow$  6.x  $\Rightarrow$  8.x  $\Rightarrow$  10.x has been accompanied by about 40 nsec of "DC" timing offsets. Motorola tasked CNS to calibrate the new M12+ receiver in 2002.



Tac32Plus software simultaneously processes data from four Time Interval Counters and four CNS Clocks, writing 12 logs continuously.

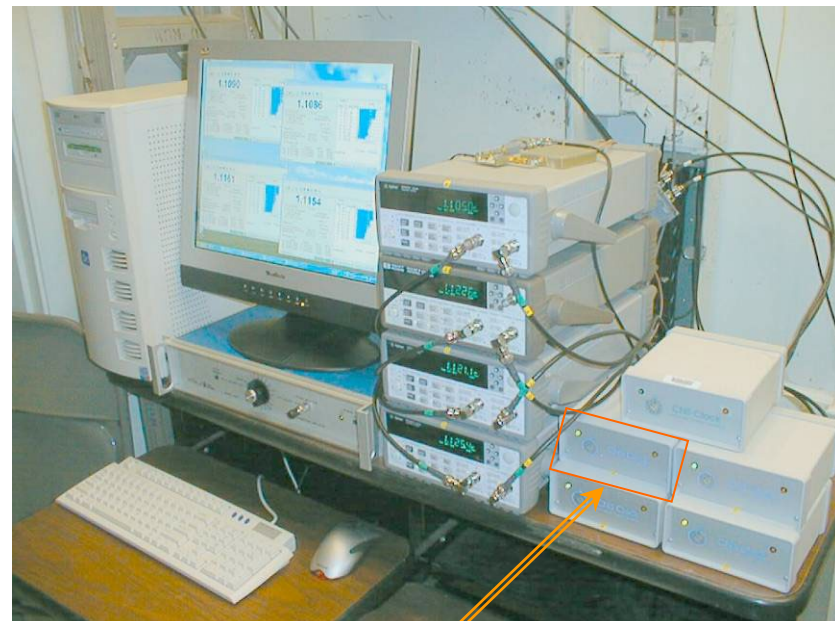

Time Interval Counters compare the 1PPS from each CNS Clock (M12+) against the USNO's UTC time tick.

**This is the "Gold Standard" "A" receiver that we used for subsequent calibrations.**

# Trying to keep up with New Technology!

- Motorola quit the GPS business in 2005. The M12 design was licensed to iLotus in Singapore. The current variant is the M12M.
- Anticipating the need for an M12 replacement, Synergy Systems LLC and CNS Systems, Inc. developed the SSR series of receivers. These are form, fit, and function replacements for the M12 using u-blox GPS modules.
- The latest version of this new receiver has improved hardware, firmware and the u-blox M8T/F GNSS module that supports multiple satellite systems. This is standard in the latest CNS Clock II product.
- CNS has an upgrade kit for the original TAC and CNS Clock units that replaces the obsolete Motorola VP and UT+ receivers with the latest SSR-M8T+ board.

# Comparing an M12+, M-12M & SSR GPS Receiver

An iLotus M-12M receiver.  
The M12+ looks the same

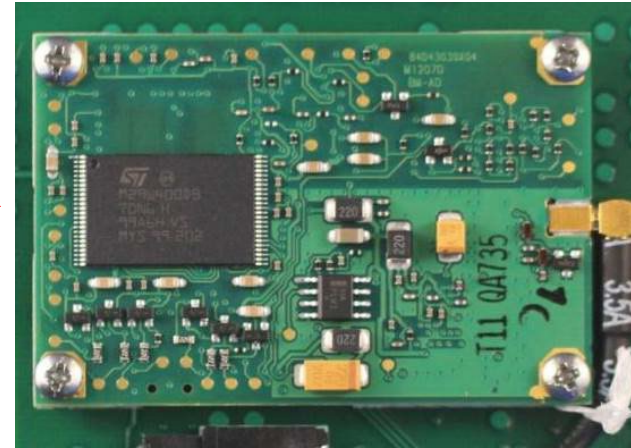

The Synergy SSR-M8T Receiver

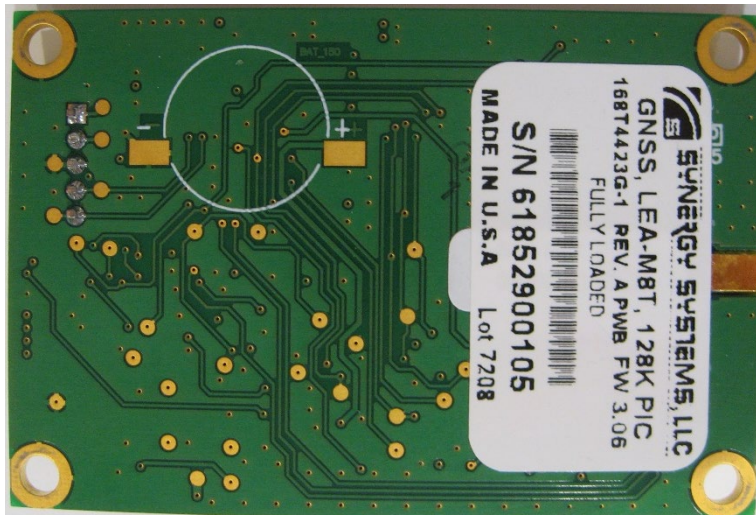

The u-blox LEA-M8T module

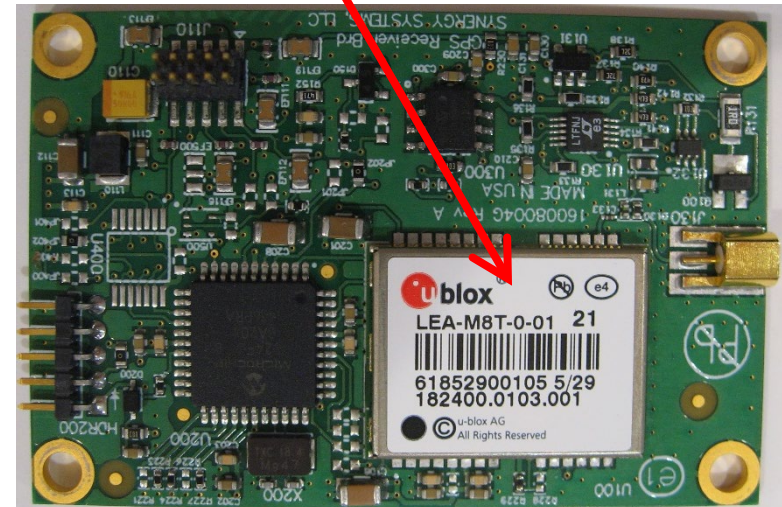

# A Four Receiver Test @ GGAO

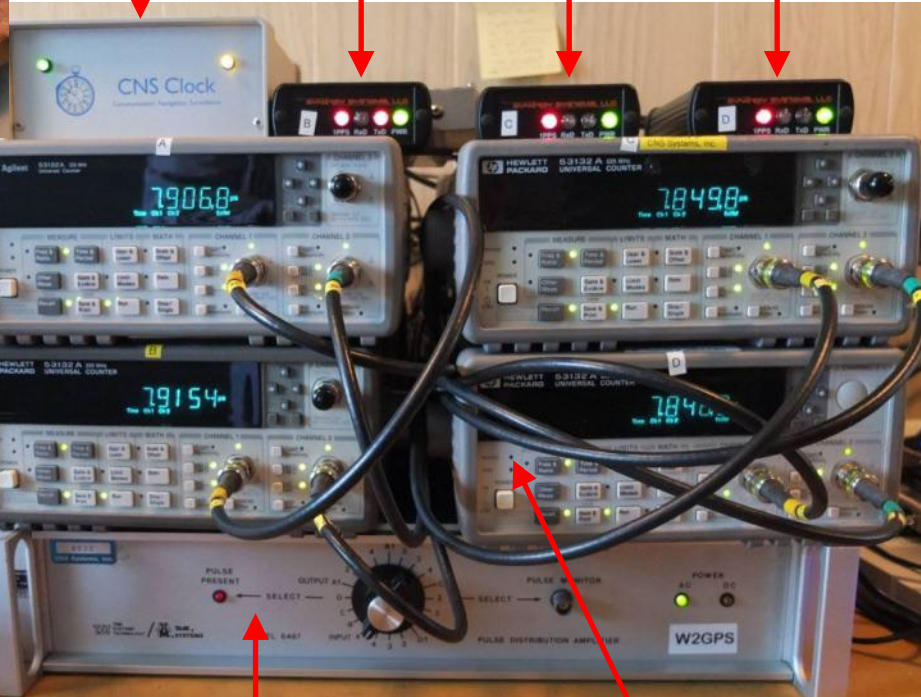
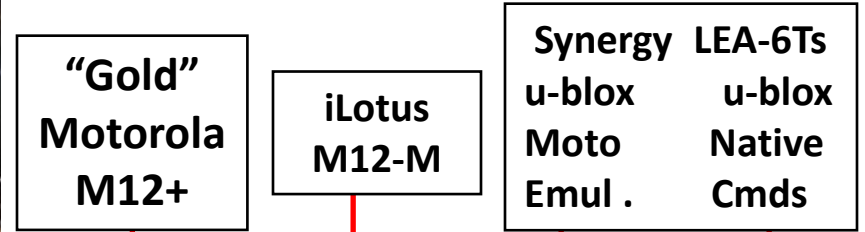
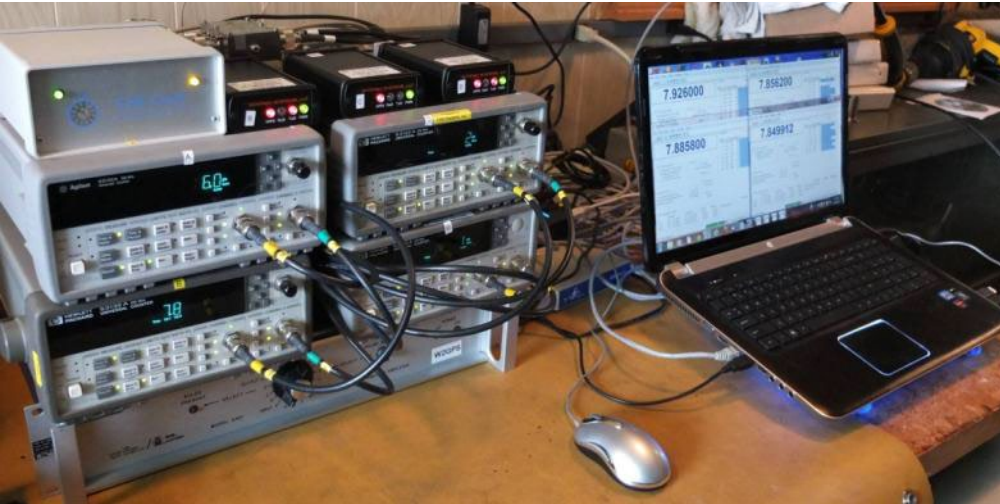

**Maser 1PPS Distributor**

**Four HP53132 Counters**

# Raw Measurements

10 days of 1-minute averages of  
Sigma-Tau 1pps tick to each of 4 rcvrs.  
Maser rate  $\sim 27.3$  nsec/day  
Clock offsets  $\sim 8 \mu\text{sec}$

GPS LATE TO MASER 1PPS TICK,  $\mu\text{Sec}$

- A: MOTOROLA M12+ "Gold Standard"
- B: MOTOROLA/iLOTUS M12M
- C: u-blox 6T (Motorola Emulator)
- D: u-blox 6T (u-blox Native)

8/17/12 0:00      8/19/12 0:00      8/21/12 0:00      8/23/12 0:00      8/25/12 0:00      8/27/12 0:00      8/29/12 0:00

# Modified Allan Deviation

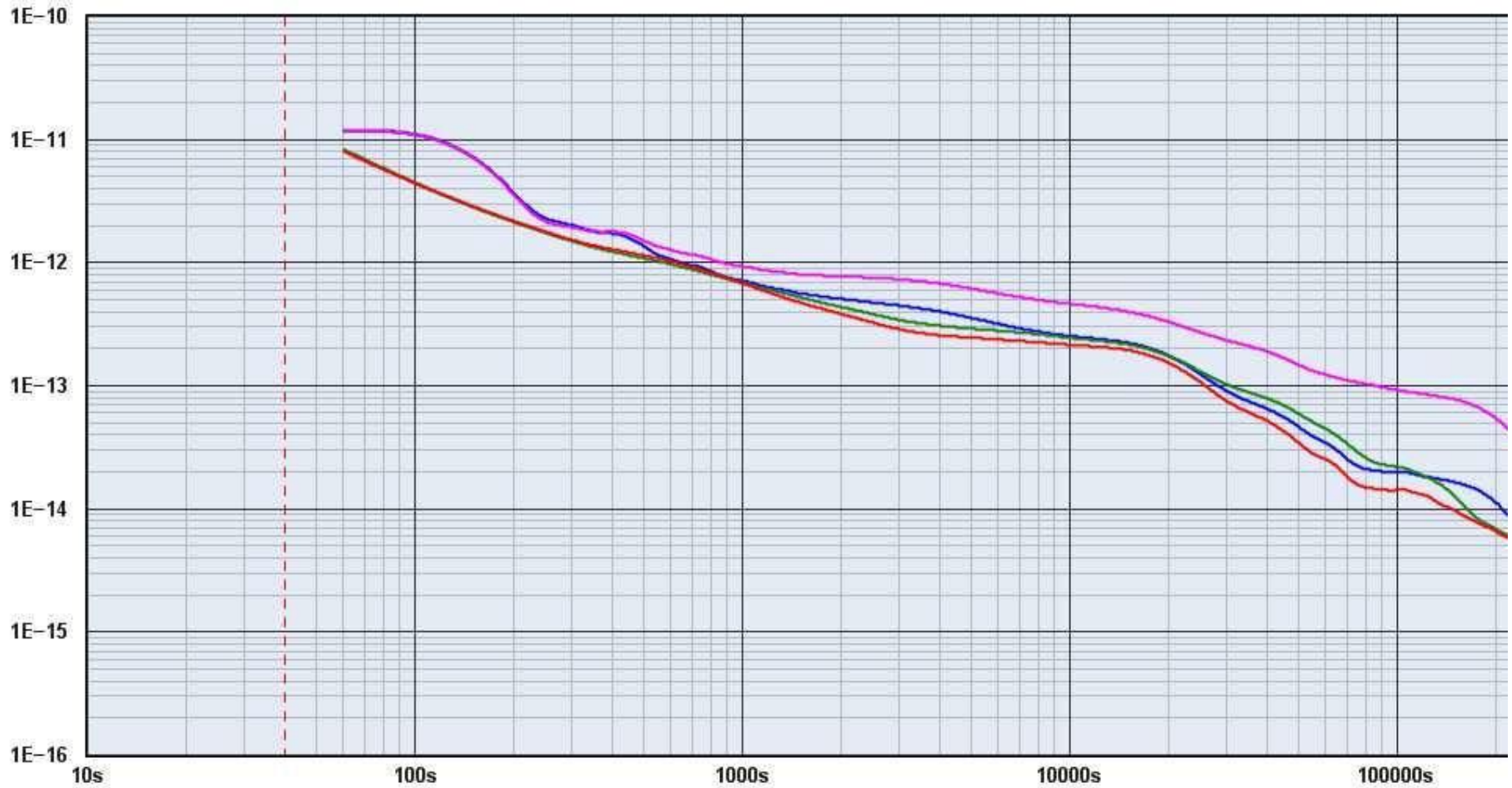

Trace	Notes	Filename	Pathname	Input Freq	Sample Interval	MDEV at 40s
GGAA_A (Unsaved)	Motorola "Gold" M12+			60 Hz	60 s	
GGAA_A (Unsaved)	iLotus M12M			60 Hz	60 s	
GGAA_A (Unsaved)	uBlox 6T, Motorola Emulator			60 Hz	60 s	
GGAA_A (Unsaved)	uBlox 6T, uBlox native			60 Hz	60 s	

# A New Test with CNS Clock II rev L Receivers

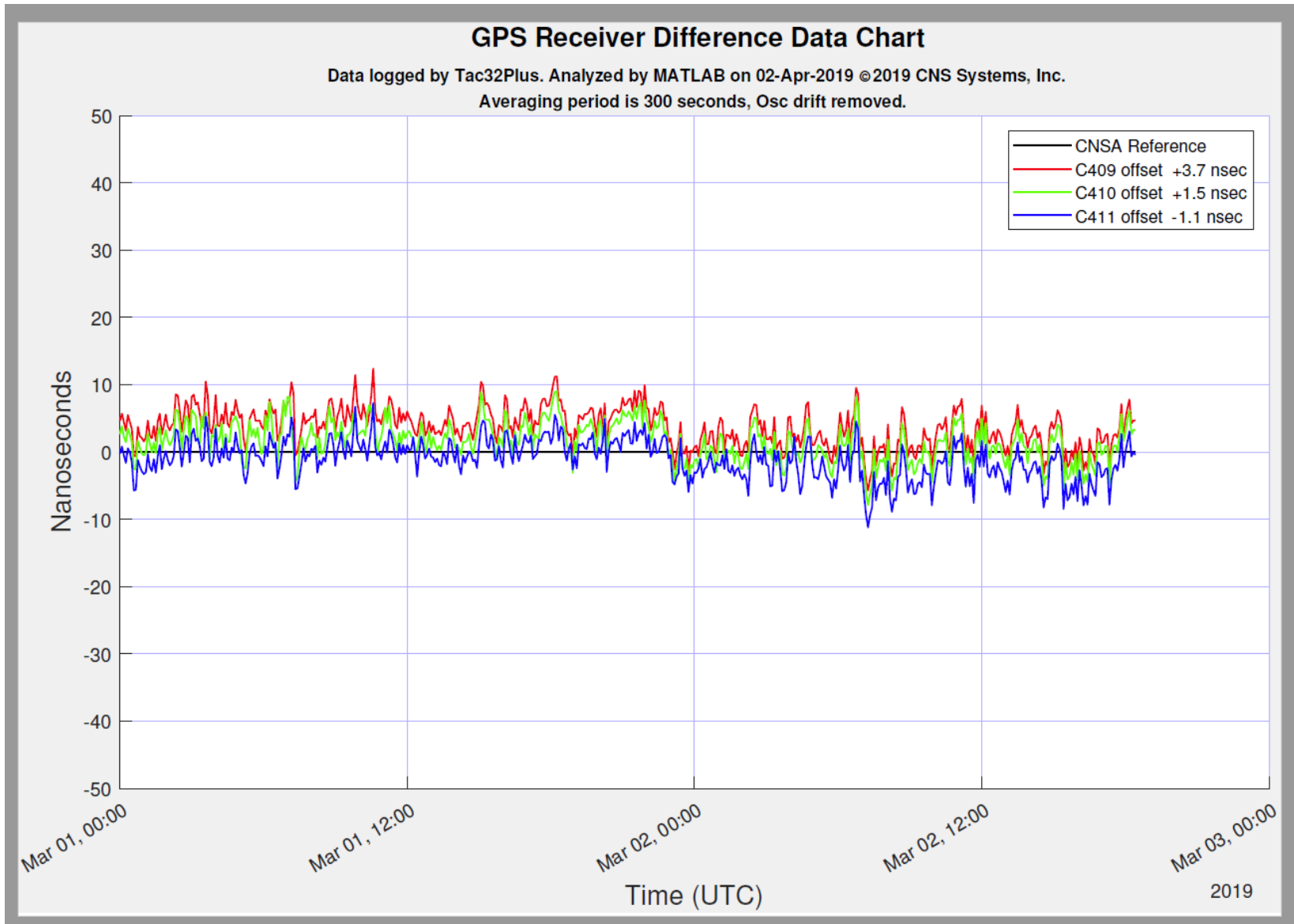

# Conclusions

1. Small, low-cost GPS receivers can provide timing needed for VLBI anywhere in the world. This is not a new statement; it's been true since the 1990's! See [www.cnssys.com](http://www.cnssys.com) under the “Publications” tab for “Timing for VLBI” notes from the IVS TOWs for more details.
2. Existing designs based on Motorola/iLotus M12s should have no problem in making the change to u-blox by using the Synergy SSR-M8T/M8F receivers.
3. The Synergy SSR receiver with the uBlox LEA-M8T/M8F (GNSS) is a superior product. **In fact, the u-blox we tested were a factor ~5 BETTER than the M12's** in all tests. When used in the CNS Clock II with its quantization correction circuit, the UTC offset is set based on a chart in the latest manual. Just plug that value into Tac32Plus or GPSTime and all is good.



# Obsolescence Issues – GPS Receivers

Motorola UT+ receivers, used in some original CNS Clocks have failed due to the week rollover event. These now provide the wrong date and time.

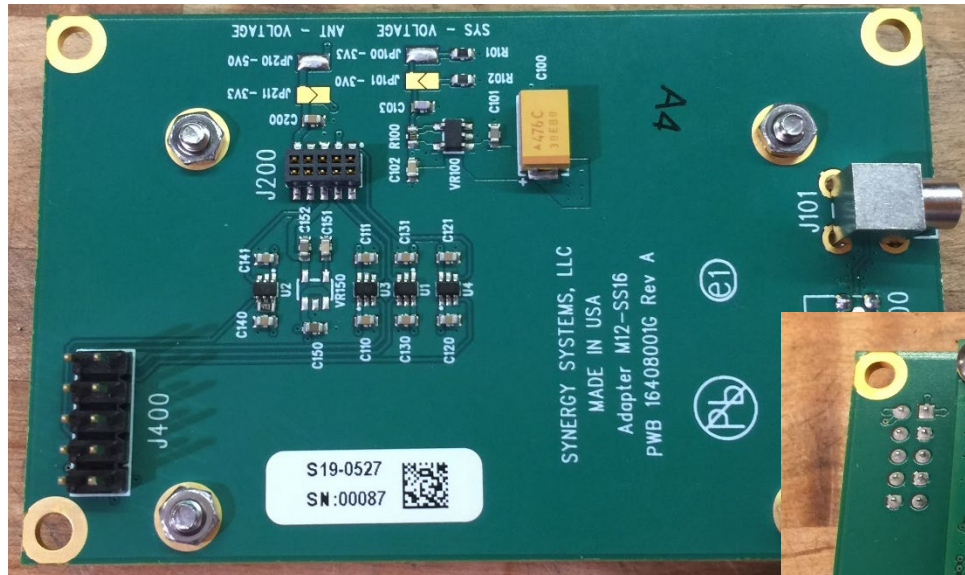

A receiver upgrade kit is available for original TAC and CNS Clock units.

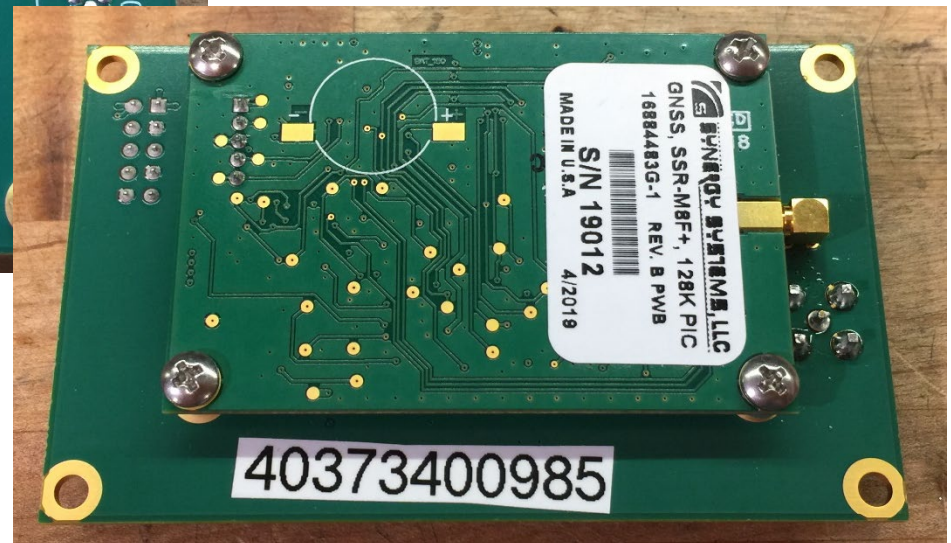

Replaces old Motorola VP and UT+ with new SSR-M8T (u-blox) receivers.

# Obsolescence Issues – Time Interval Counters

Agilent announced “End-of-Life” for the 53131 and 53132 counters that have been the standard VLBI Time Interval Counter. These use a simple RS232 printer port interface. Tac32Plus was built around this capability.

Agilent is recommending the 53230A as their suggested replacement for the 131/132. This is the counter that CNS is now using. Berkeley Nucleonics offers their Model 1104 as an alternative.

Both these counters use Ethernet ports for control and data. This allows Tac32Plus and GPSTime to implement setup commands and collect data, simplifying station operation and interface wiring.

# Tac32Plus & GPSTime Support Time Interval Counters via Ethernet.

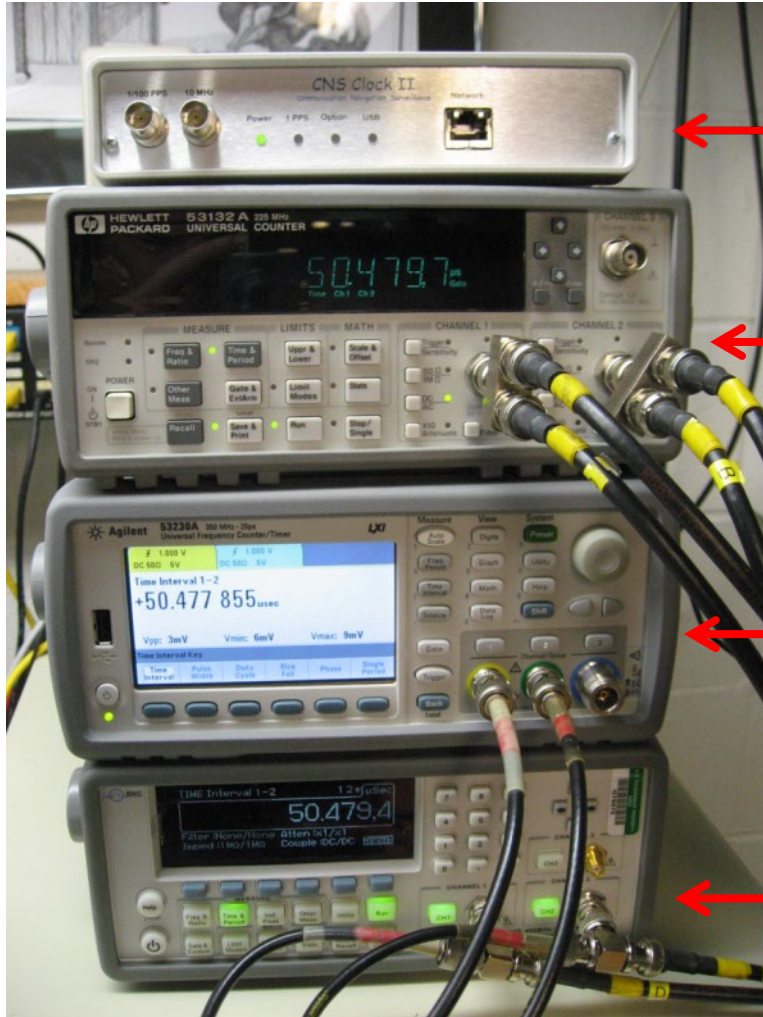

CNS Clock II

HP/Agilent  
53132A  
Serial Port

Agilent  
53230A  
Ethernet

Berkeley Nucleonics  
Model 1104  
Ethernet

Tac32Plus\_COM13 2.7.23

File Edit View Data Display Help

**18:39:03.000**

UTC Time from GPS  
 UTC Day #117 18:39:03.000  
 Saturday, 27 Apr 2019  
 GPS Week = 2050  
 UTC = GPS - 18 seconds

PC Time  
 14:39:02.995  
 Eastern Daylight Time  
 Latency: 0

Sidereal Time  
 Local Mean Sidereal Time 03:54:28.78  
 Greenwich Mean Sidereal Time 09:00:53.77  
 Modified Julian Day 58600.77712

Grid Square  
 FM19qc.71

TIC (usec)  
 31.533700

GPS Navigation Data

	Latitude	Longitude	Alt(GPS)	Alt(MSL)
Cur:	39° 5' 25.1850"	-76° 36' 14.8320"	20.80m	55.55m
Avg:	39° 5' 25.1850"	-76° 36' 14.8320"	20.80m	55.55m
Ref:	39° 5' 25.1956"	-76° 36' 14.8349"	20.87m	54.98m

Satellites

PRN	EI	Azm	Eb/No	5	15	25	35
7	70	↑	188	30			
11	68	↑	145	30			
30	63	↑	293	31			
18	52	↑	110	31			
8	48	↑	45	31			
1	42	↑	149	25			
28	34	↑	296	28			
27	15	↑	51	22			
17	12	↑	234	21			
13	11	↑	318	23			
9	8	↑	207	16			

Position Hold 12 Visible 11 Tracked

For Help, press F1

Position Hold Ant OK Motorola SSR-M8F+, Bin, 12 ch, V7.03, FW V3.28

Tac32Plus

Note: GPS time vs. HP5065A  
Rubidium CNS Systems'  
time standard

# Tac32Plus & GPS Support Time Interval Counters via Ethernet.

The screenshot displays the Tac32Plus software interface. The main window shows a large digital display of '22:22:11.000'. Below this, it displays 'UTC Time from GPS' (UTC Day #292, 22:22:11.000, Thursday, 18 October 2012, GPS Week = 1710, UTC = GPS - 16 seconds) and 'PC Time' (18:22:10.980). On the left, there are sections for 'Sider Local Green Modifi' and 'GPS' (Cur, Avg, Ref). Three 'TIC Serial Port Settings' dialog boxes are overlaid, each for PORT 1, PORT 2, and PORT 3. Each dialog box has a 'PORT' dropdown (PORT 1, PORT 2, PORT 3), a 'COM' dropdown (COM14, TCP/IP), 'Stop Bits' (1 bit, 2 bits), 'Data Bits' (7 bits, 8 bits), 'Parity' (None, Odd, Even, Space, Mark), 'Handshake' (None, Xon/Xoff, RTS/CTS, DTR/DSR), and 'TCP/IP Address' (10.10.10.51, 10.10.10.50). There are 'OK', 'Cancel', and 'Probe for Serial Ports' buttons in each dialog. To the right, two 'TIC Data (Raw)' windows show a list of time interval counter data points, such as '1 50.505,4 us' and '2 5.050690000000000e-005'.

TIC Setup is simple and familiar 53132A vs. BN1105 53132A vs. 53230A

# Tac32Plus Upgrades (2019 -> 2023)

## Version 2.7.24 -> 2.7.32

- Correct the identification of GPS module firmware version numbers.
- Implement support for the new @@SP "Second PPS Rate" command and response.
- When using the @@Sc manual command, include the Satellite Selection in the GPS Mode Selection window.
- When in UBX binary mode, correct the mode settings and transitions between Navigation, Position Hold (0D) and Survey.
- Correct the calculations used to resolve the automatic sawtooth correction add vs. subtract determination.
- Improve the decoding of @@Bn and @@En messages.
- Revise the decoding of special emulation modes for the SSR series receivers and add a new mode.
- Revise the detection of receiver types so the special emulation modes of the SSR series receivers are correctly detected.
- Enable some supported features in the GPS Receiver Mode Selections window for the CNS Clock II and other SSR receivers in Motorola Binary mode. This includes Satellite Activation and Application Type.
- Enable and implement self-survey in u-blox UBX mode.
- Change the file extension of GPS receiver PVT logs from "txt" to "csv" and correct the column header for the PVT log files.
- Correct the encoding of baud rates for the UBX pass-through mode.
- Provide support for short PPS on CNS Clock II, rev L and newer, starting with serial number 404409.
- See <https://www.cnssys.com/Tac32Plus/Tac32Plus.php>

# Future Enhancements - GPSTime Software

- Multi-Platform executables, especially Linux.

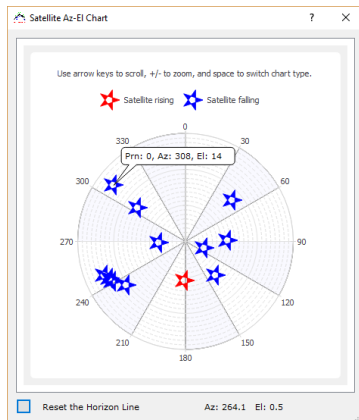

GPSTime V1.0

File Edit View Data Display Help

**19:12.59.000**

UTC Time from GPS  
UTC Day #115 19:12.59.000  
Thursday, 25-Apr-2019  
GPS Week = 2050

PC Time  
20:00:00.001  
Eastern Daylight Time  
Latency: 1

Sidereal Time  
Local Mean Sidereal Time 04:20:37.25  
Greenwich Mean Sidereal Time 09:27:02.24  
Modified Julian Day 58598.80068

Grid Square  
FM19qc.71

TIC (usec)

GPS Navigation Data

	Latitude	Longitude	Alt(GPS)	Alt(MSL)
Cur:	39° 5' 25.1890"	-76° 36' 14.8650"	8.62m	43.37m
Avg:	39° 5' 25.1599"	-76° 36' 14.8459"	8.62m	43.37m
Ref:	39° 5' 25.1956"	-76° 36' 14.8349"	20.87m	54.98m

For Help, press F1

Navigation: Navigating    Ant OK    Initialization: Set up Motorola GPS Receiver...

Satellites

PRN	El	Azm	Eb/No	Eb/No
1	53 ↑	138	29	GPS
7	57 ↓	181	29	GPS
8	37 ↓	49	31	GPS
11	73	109	29	GPS
13	14	308	21	GPS
17	21	242	26	GPS
18	54	89	31	GPS
28	42	305	30	GPS
30	68	265	32	GPS
131	29	233	25	SBAS
133	20	244	25	SBAS
135	17	247	28	SBAS

5 | 15 | 25 | 35

11 Visible 10 Tracked

3-D Fix, DGPS  
PDOP = 1.7

# Future Enhancements:

## **CNS Clock II:**

- TCP/IP or UDP/IP data interface.
- Internal Web page setup.
- Expanded IRIG capabilities.
- Firmware updates using Ethernet.

Other enhancements based on user feedback.

Contact Richard Hambly: [rick@cnsys.com](mailto:rick@cnsys.com)

# Questions ?





# Appendix

- IVS Recommended Maser Timing Practices

# IVS Recommended Maser Timing Practices

**IVS Memorandum 2014-001v01**

**29 April 2014**

**“IVS Recommended Maser  
Timing Practices”**

***Roberto Ambrosini, Tom Clark,  
Brian Corey, Ed Himwich***

# IVS Recommended Maser Timing Practices

From: Roberto Ambrosini, Tom Clark, Brian Corey, and Ed Himwich

To: All IVS Stations

Date: 1 May 2014

We recommend the following practices for management of the 1 PPS derived from the Maser and used as the station 1 PPS. Its synchronization with UTC as derived from the GPS 1 PPS offers a common timing reference for all VLBI stations worldwide. We refer to the difference in the epochs of the Maser and GPS 1 PPS signals, as measured by a counter, as the Maser/GPS offset, regardless of which signal occurs later.

Because it is evident that crossing zero time for the Maser/GPS offset should be carefully avoided (the counter would read the complement of one second of the desired delay, arithmetic processing of data by the counter not being recommended), we recommend keeping the offset at a small but significant distance from zero and its drift rate positive.

We also recommend keeping the time and frequency retuning of the Maser at a minimum, typically no more than once in a year.

This procedure offers: less work at the station, better modelling of the long term drift of the Maser, and a better chance to identify jumps in the offset.

Here follow some practical recommendations for the Maser/GPS offset:

- (1) Either the Maser 1 PPS or GPS 1 PPS can occur first.
- (2) The offset should be significantly, at least a few microseconds, different from zero.
- (3) The offset should not be too large, a useful upper limit might be on the order of 100 microseconds.
- (4) The offset should be growing slowly, typically less than 0.1 microseconds/day.
- (5) The offset should not be adjusted unnecessarily, no more often than once per year if possible.
- (6) Items (2)-(5) are only recommendations and may not be feasible in some situations and do not need to replace existing successful practice at any station. However to the extent it is reasonable, stations should align themselves with these practices.

# IVS Recommended Maser Timing Practices

Recommendation (1) is a recognition that different stations have different preferences on which 1 PPS occurs first: Maser or GPS.

Recommendations (2)-(4) are intended to minimize both the need to re-tune the Maser and the chances of the offset going through zero.

Recommendation (5) is intended to make it easier to relate the offset data from one experiment to another.

For completeness, the following requirements (as opposed to recommendations) are listed for the FS log recorded offset between GPS and formatter 1PPS signals, the "GPS/FM offset". These requirements are necessary to allow correct interpretation of the offset data downstream. Please note that these requirements deal with the GPS/FM offset, which is related to, but different from Maser/GPS offset discussed above. In addition to the GPS/FM offset, stations can, and are encouraged to, record (appropriately labelled) additional available clock offset data, including the Maser/GPS offset, in their FS logs or separately.

The requirements for the GPS/FM offset recorded in the FS logs:

- (7) The offset is positive and small, i.e. close to (but not too close to) zero and NOT close to one second. If the recommendations (2)-(4) for the Maser/GPS offset above are used for that offset, they are likely to also be true for the GPS/Maser offset as well. In any event, the GPS/FM offset should not cross zero.
- (8) The offset is recorded with either of two possible commands depending on how the counter is connected. The connections should be chosen to agree with (7) and:
  - (A) If the counter is started by the GPS 1 PPS, use the "gps-fmout" command. This should be the case if the formatter output 1 PPS (usually determined by the Maser) is late.
  - (B) If the counter is started by the fmout 1 PPS, use the "fmout-gps" command. This should be the case if the GPS 1 PPS is late. It will be necessary to change which command is used if which signal is late changes. This should not be needed if recommendations (2)-(4) for the Maser/GPS offset are followed.
- (9) The offset counter does not use arithmetical processing. It just reports the "raw" difference in time between the start and stop signal. So for example, the small positive offset in (7) is not achieved by subtracting the raw difference from 1 second.
- (10) The offset counter does not use averaging. This allows immediate detection of jumps. Averaging can be applied in post processing of the data.
- (11) The offset must be measured at least once per scan in MIDOB. Additional measurements are acceptable as well.