

AMSAT OSCAR-E Project Summer 2003 Status Report

by
Richard M. Hambly W2GPS

This status report about AMSAT-OSCAR-E ("Echo") is a companion article to the presentation given at the Dayton Hamvention in May 2003 and the to the previous articles published in the AMSAT Journal^{1,2} and CQ/VHF^{3,4}.

BACKGROUND:

The AMSAT OSCAR-E satellite, also known as "Echo", was conceived by the AMSAT Board of Directors when on October 8, 2001 they initiated review of "a new small satellite project." Since that time an expanding team of AMSAT volunteers have been working in cooperation with our contractor SpaceQuest on the design, construction and launch preparations for this new satellite.

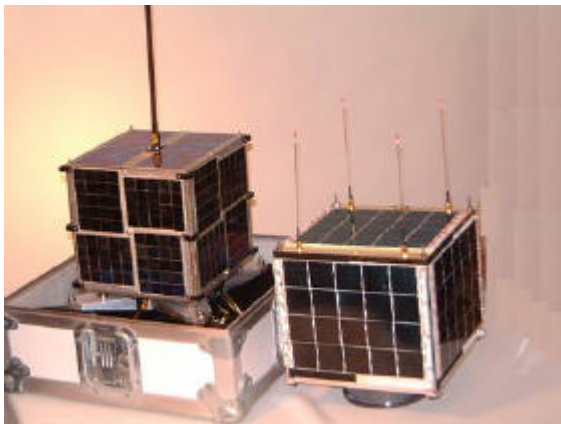

Figure 1: Original Microsat model (left) and Echo mechanical model (right)

Echo is a Microsat class satellite that owes a great deal to the heritage of the original AMSAT Microsats AO-16, DO-17, WO-18, and LO-19 that were launched in 1990 and to the AMRAD-sponsored Microsat AO-27 that was launched in 1993. As shown in Figure 1 Echo is a small cube about 9.5" (25 cm) on a side, like those first Microsats. It is made up from a stacked set of aluminum

trays and covered on all sides by solar panels.

SUMMARY OF FEATURES

Echo will offer capabilities that will appeal to users with a wide range of interests from "EasySat" operations to scientific experiments. Here are the highlights:

- Mode V/U, L/S and HF/U Operation. Modes V/S, L/U and HF/S are also possible.
- Analog operation including FM voice.
- Digital modes. Store and forward operation is planned. Many speeds are possible but 9.6, 38.4, 57.6K and 76.8Kbps are the most likely.
- PSK31 repeater mode using 10-meter SSB uplink and UHF FM downlink.
- Four VHF receivers and two UHF high power 8-Watt transmitters.
- Can be configured for simultaneous voice and data.
- Has a multi-band, multi-mode receiver.
- Can be configured with geographical personalities.
- Advanced power management system.
- Digital Voice Recorder (DVR).
- Active magnetic attitude control.

TECHNICAL OVERVIEW

Echo's internal subsystems have been refined and modified since they were described in the previous articles. As you will see in the following figures significant progress has been made and Echo's hardware is taking shape.

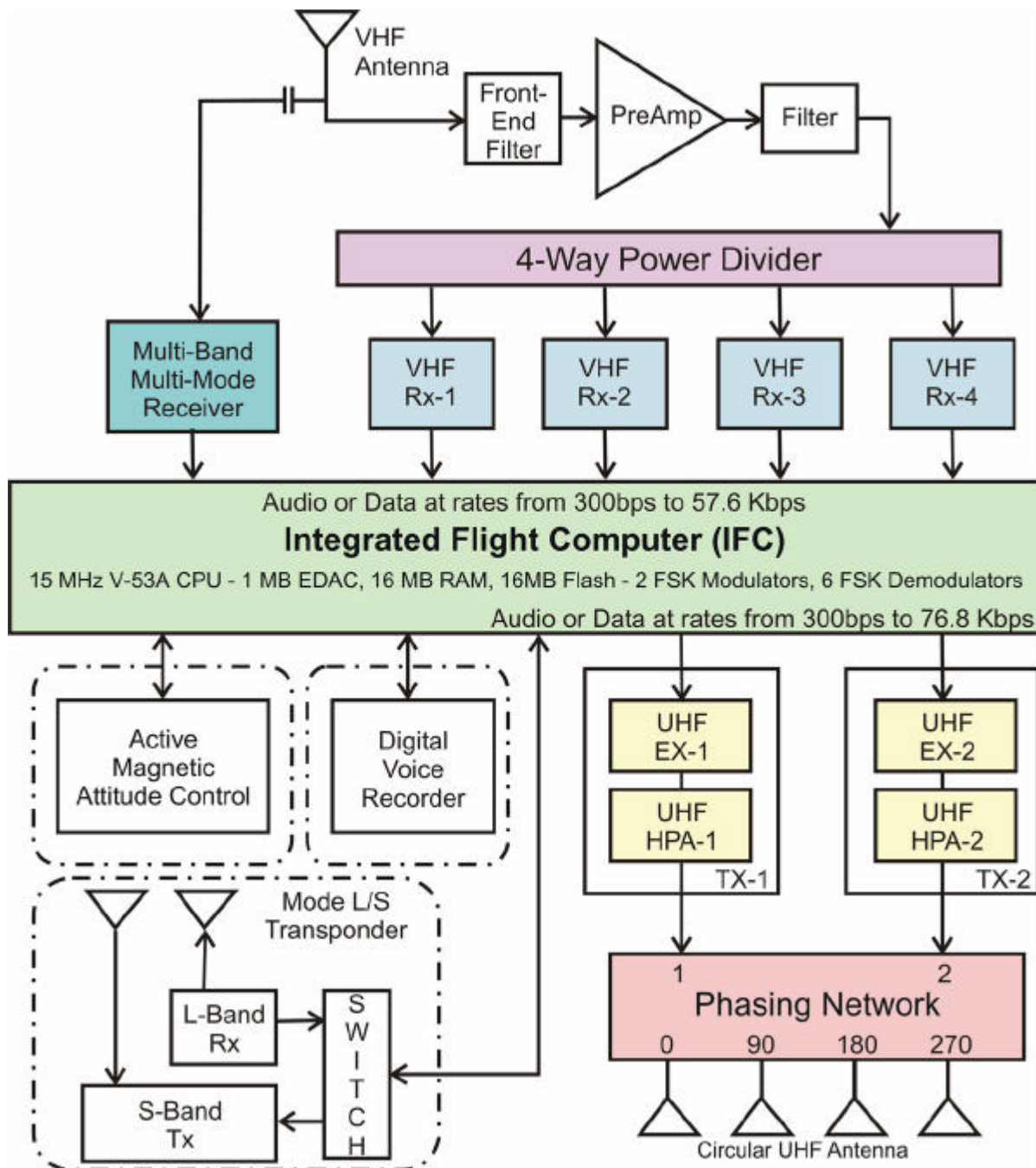

Figure 2: Block Diagram of the Echo Spacecraft

As shown in Figure 2, Echo is made up of a number of modules and subsystems including:

- Four VHF receivers.
- A Multi-Band Multi-Mode Receiver.
- Two UHF transmitters.
- Six demodulators and 2 modulators.
- Integrated Flight computer.
- Batteries, BCR, Regulators (not shown).
- Wiring harness, RF cabling.
- RF switching and phasing networks.
- 56 channels of telemetry.
- Magnetic attitude control.

STRUCTURE

As shown in Figure 3 Echo is made up from six trays each made from solid blocks of 6061-T6 aluminum and stacked with stainless steel sheer pins and four 4-40 tie-down rods. The tray dimensions are:

- Receiver tray: 58mm with 2mm base.
- CPU tray: 24.8mm with 2mm base.
- Charger tray: 24.8mm with 2mm base.
- Battery tray: 38mm with 2mm base.
- Payload tray: 58mm with 2mm base.
- Transmitter tray: 39mm with 9mm base.

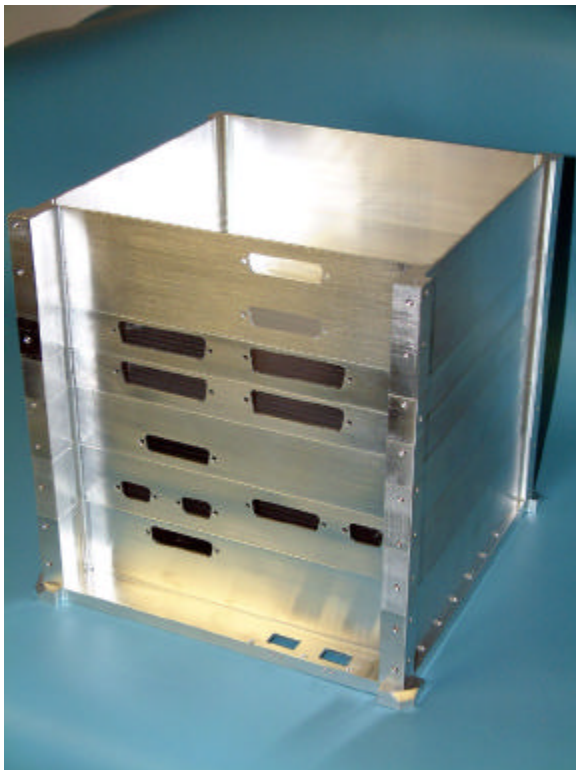

Figure 3: Echo's Trays

Thus Echo has overall dimensions of approximately 9.5" x 9.5" x 9.5".

RECEIVERS

Echo has four miniature VHF FM receivers each consuming less than 40 mW of power and weighing less than 40 gm each. Each receiver has 2-channel capability although the second channel is not planned to be used. The sensitivity of each receiver is -121dbm for 12db SINAD.

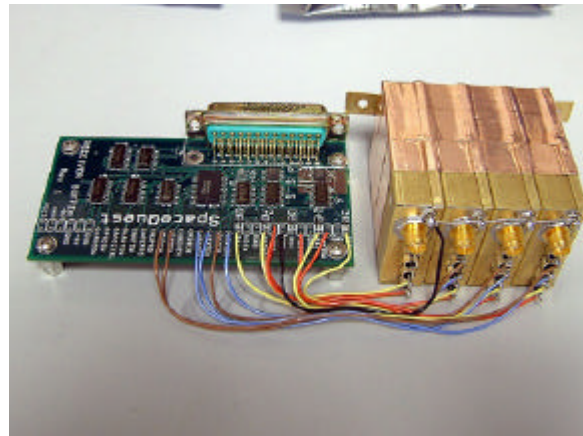

Figure 4: Four VHF Receivers and Interface Board

TRANSMITTERS

Echo has two UHF FM transmitters that can be operated simultaneously. Each transmitter can be operated at any power level from 1 to 8 watts output. The transmitters are frequency agile in 2.5KHz steps and are tunable over about 20 MHz.

MULTI-BAND RECEIVER

Echo has a single all-mode receiver capable of receiving signals on the 10m, 2m, 70cm and 23cm Ham bands and possibly on other frequencies. Its performance is limited primarily by the performance of the broadband antenna, which will probably be shared with the 2-meter whip antenna.

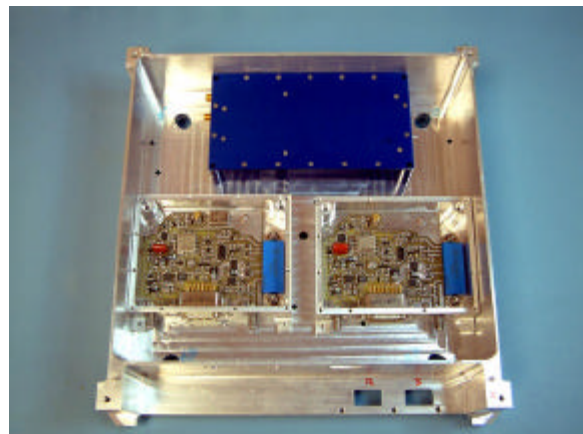

Figure 5: Multi Mode Receiver (rear) and two UHF Transmitters

ANTENNAS

Echo's antenna design has undergone a number of revisions and is still in a state of flux. At present there are three antennas:

- A VHF 18" whip on top.
- A UHF "Mary" Turnstile on bottom.
- An L+S band "open sleeve" antenna on the bottom.

The Multi-band Multi-Mode receiver shares the VHF whip.

The two UHF transmitters are fed through a phasing network to the "Mary" UHF antenna, resulting in one UHF transmitter having right hand circular polarization and the other UHF transmitter having left hand circular polarization.

LINK BUDGET DATA

Echo's UHF transmitters are adjustable from 1 to 8 Watts. Maximum efficiency is achieved at 8 Watts and that is the expected operating power level.

Antenna gain on the UHF is +2 dBic at +/- 45 degrees to -6 dBic at the backside of the spacecraft.

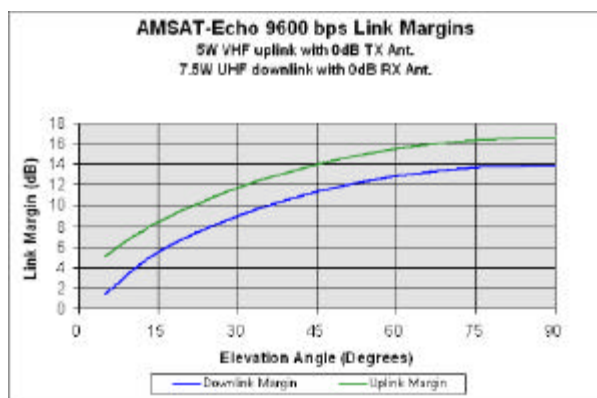

Figure 6: Mode V/U Link Margin Graph

The VHF antenna feeds a low noise amplifier (LNA) with 0.7db noise figure and 20db of gain. The LNA is followed by a band pass filter with 1.5db of loss. The

overall receiver performance is -125 dbm for 12db SINAD.

DATA MODES

The modulation is either narrow band FM voice or data using baseband shaped raised-cosine-in-time FSK. Many data rates are possible but 9.6, 38.4, 57.6K and 76.8Kbps are the most likely rates to see operational use. To be more specific, it is expected that 9.6K and 57.6Kbps will be used on uplinks and 9.6, 38.4, and 76.8Kbps on downlinks.

The 57.6K waveform is about 100 KHz wide so it can't be used on the VHF uplink. The L-band uplink utilizes the multiband receiver that has both narrow and wide band filters. Unfortunately, the 57.6K L-band uplink will be less than optimal because the receiver's wideband FM mode bandwidth is 150KHz; it will take extra uplink power to overcome the additional noise from the mismatched filter bandwidth.

Downlinks will be 9.6Kbps on UHF (57.6Kbps is possible but not likely). Downlinks on S-band will be 9.6Kbps initially with 38.4Kbps and 76.8Kbps in use later. I expect we will run S-band at 9.6Kbps to test and get folks with AO-40 stations interested, then move to 38.4Kbps and 76.8Kbps to get users excited about those faster speeds and gain experience on how they work with regard to Doppler.

We are looking forward to using 57.6Kbps, however no ground equipment currently exists to support it so operation of uplink or downlink at this speed will have to wait until some equipment becomes available.

INTEGRATED FLIGHT COMPUTER

The Integrated Flight Computer (IFC) was developed by Lyle Johnson KK7P. It is a flight proven board with a power consumption of less than 300 mW. The IFC includes advanced features including six receive and six transmit serial communication channels, 1 MB of error-

detecting and correcting (EDAC) memory, 16 MB RAM, and 16MB flash memory for mass storage.

The IDC also has six agile demodulators and two agile modulators to support data communications.

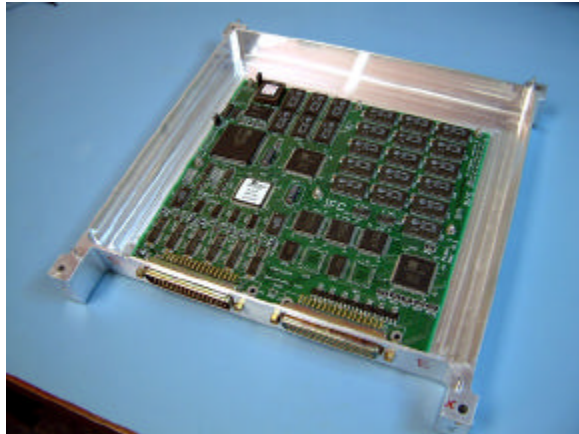

Figure 7: Integrated Flight Computer

SPACECRAFT FLIGHT SOFTWARE

Echo's software consists of a boot loader, kernel, operating system and applications. Echo will use the Spacecraft Operating System (SCOS), which has been used on all of the Amateur Radio Microsat projects to date. Harold Price NK6K should be thanked for allowing AMSAT to use SCOS.

The software development team consists of Bob Diersing N5AHD, Jim White WD0E, Harold Price NK6K, Lyle Johnson KK7P, and Skip Hansen WB6YMH.

Bob Diersing N5AHD has agreed to update the boot loader. A test version of boot loader is now complete. This is the first step to enable the rest of the software effort.

The SCOS kernel port has started. Enhancements are planned to be made to the SCOS drivers and supporting software.

A Windows command and telemetry program for the ground station is about 50% complete at the time this is being written. A Windows based boot loader prototype for

the ground station is done. The housekeeping task has been created and will soon be tested.

The communication protocol for the Digital Voice Recorder interface is documented.

SOLAR PANELS

Echo will have six high efficiency Solar Panels. The panels will use triple junction MCORE GaAs cells that are nearly 27% efficient. This results in about 20 Watts of power generation capacity when not in eclipse (12-14 Watts per side).



Figure 8: Mark Kanawati N4TPY Preparing to Bond Solar Cells to the Panels.

POWER DISTRIBUTION

Echo is equipped with a matched set of six NiCd cells that have a capacity of 4.4 Amp-Hours each. The output of the battery subsystem is nominally 8 Volts DC.

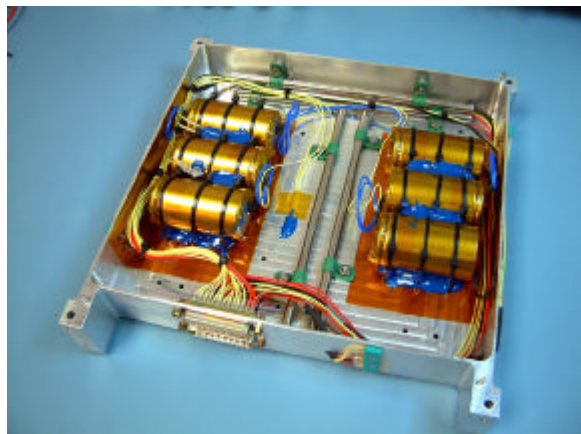

Figure 9: Battery Tray

The interface between the solar panels and the batteries is through the Battery Control Regulator (BCR). This critical subsystem is designed to be autonomous and fail-safe so that the batteries are protected above all else.



Figure 10: Battery Control Regulator

The BCR operates at 50KHz with 89% efficiency. It charges the battery using only solar panel power, so is capable of charging a dead battery. The BCR prevents the battery from overcharging or depleting completely at any temperature and provides the necessary voltages and telemetry.

ATTITUDE CONTROL

A new experimental active magnetic attitude control has replaced the passive system used on previous Microsats. This design by Doug Sinclair VA3DNS consists of a torquer rod and a charging module.

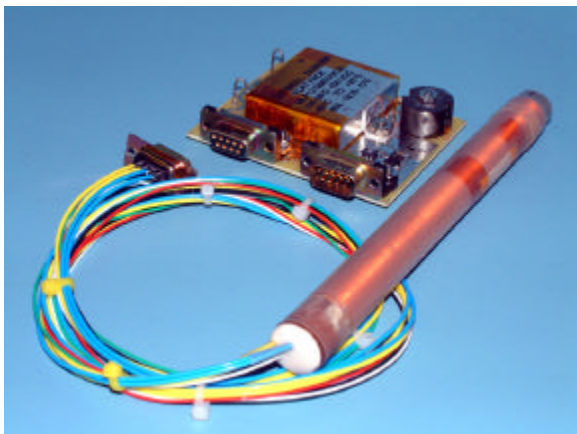

Figure 11: Active Magnetic Attitude Control

The torquer rod is a semi-permanent magnetic rod whose strength and polarity are adjustable by applying a charging current over a period of up to 15 seconds, where 15 seconds imparts a maximum charge. This allows some control over the satellite's attitude relative to the Earth's magnetic field. It also permits us to turn the satellite upside down.

DIGITAL VOICE RECORDER (DVR)

Echo will be equipped with a multi-channel digital recorder. This recorder can sample audio from a selected receiver output with 16 bits resolution at a rate of 48K samples/second. Recordings can be played back on any of Echo's downlink channels.

The DVR is based on the same ARM7 processor planned for use in the IHU3 for upcoming high-orbit missions. It has up to 64MB of RAMdisk storage, providing almost 12 minutes recording time.

INTEGRATION LAB

Thanks to the efforts of Ron Parise WA4SIR, NASA Goddard Space Flight Center has returned the AMSAT Integration Lab to us. This building was constructed in the Spring of 1978 on the grounds of what is now the NASA Visitor's Center by NASA and a group of Hams led by Jan King W3GEY and Tom Clark W3IWI.



Figure 12: AMSAT Integration Lab at NASA

The Integration Lab was used between 1978 and 1988. It was instrumental in the construction of the Phase 3A satellite and Oscar-10.

The Goddard Amateur Radio Club has helped to clear the building of the materials stored there by the Visitor's Center. We are now waiting for NASA's facility department to repair the roof and floor. Once that is done we will bring in furniture and test equipment, much of which will be provided by NASA and the Goddard Amateur Radio Club.

We are also assembling a satellite command and test station for this facility. Fortunately our satellite antenna tower is still standing and is in good condition.

LAUNCH

Echo's launch is planned for May 2004. The launch will be on a Dnepr LV (SS-18) rocket from the Baikonur Cosmodrome in Kazakhstan.



Figure 13: Dnepr LV (SS-18) Launch from Baikonur Cosmodrome in Kazakhstan, Dec 2002

CONCLUSION

AMSAT OSCAR-E ("Echo") has evolved and matured since its inception in late 2001. Many of its modules are now built and undergoing preliminary testing. Software is beginning to come together. Soon we will begin the system integration where the various subsystems will be tested in functional groupings. Then we will proceed with full satellite integration and testing.

By this time next year the Echo satellite should be in orbit providing communications services to the Ham community for many years to come.

¹ "AMSAT OSCAR E, A New LEO Satellite from AMSAT-NA", AMSAT Journal, May/June 2002, pp5-11, Rick Hambly W2GPS

² "AMSAT OSCAR-E Project Status Update, A New LEO Satellite from AMSAT-NA", AMSAT Journal, November/December 2002, pp14-17, Richard M. Hambly W2GPS

³ "AMSAT OSCAR E, A New LEO Satellite from AMSAT-NA", CQ/VHF, Summer 2002, pp13-20, Rick Hambly W2GPS

⁴ "AMSAT OSCAR-E Project Status Update, A New LEO Satellite from AMSAT-NA", CQ/VHF, Winter 2003, pp12-13,72-74, Richard M. Hambly W2GPS